

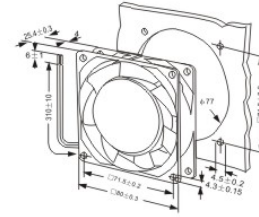

Size:80x80x25mm
 Impeller material:PBT thermoplastic black UL94-V
 Frame:Aluminum Alloy
 Motor:shaded pole induction motor
 Operation temperature:-10°C~+65°C
 Label diameter: 55mm
 Fan accessories

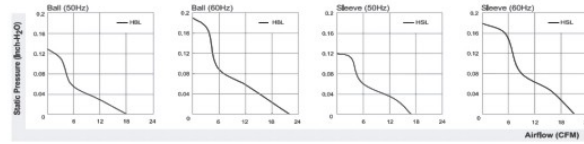

Factory Code	Model	Voltage (V)	Current (A)	Freq (HZ)	Noise (Db)	Bearing	Power (Watt)	Speed (r/min)	Air volume		connector	Packing		
									(m3/h)	CFM		pcs/ctn	weight	dimension
AF825S11L	DS8025ASHL	110	0.14	50/60	30	sleeve	14	2500	30	18	wire	80	16kg	40*40*20
AF825B11L	DS8025ABHL	110	0.14	50/60	30	ball	14	2550	32	19	wire	80	16kg	40*40*20
AF825S11T	DS8025ASHT	110	0.14	50/60	30	sleeve	14	2500	30	18	terminal	80	16kg	40*40*20
AF825B11T	DS8025ABHT	110	0.14	50/60	30	ball	14	2550	32	19	terminal	80	16kg	40*40*20
AF825S22L	DS8025ASHL	220	0.09	50/60	30	sleeve	16	2500	30	18	wire	80	16kg	40*40*20
AF825B22L	DS8025ABHL	220	0.09	50/60	30	ball	16	2550	32	19	wire	80	16kg	40*40*20
AF825S22T	DS8025ASHT	220	0.09	50/60	30	sleeve	16	2500	30	18	terminal	80	16kg	40*40*20
AF825B22T	DS8025ABHT	220	0.09	50/60	30	ball	16	2550	32	19	terminal	80	16kg	40*40*20
AF825SBIVL	DS8025ASHL	110&220	0.09/0.14	50/60	30	sleeve	16	2500	30	18	wire	80	16kg	40*40*20
AF825BIVL	DS8025ABHL	110&220	0.09/0.14	50/60	30	ball	16	2550	32	19	wire	80	16kg	40*40*20

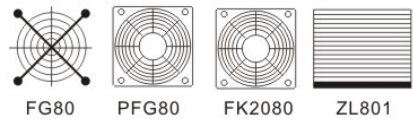

Size:80x80x38mm
 Impeller material:PBT thermoplastic black UL94-V
 Frame:Aluminum Alloy
 Motor:shaded pole induction motor
 Operation temperature:-10°C~+65°C
 Label diameter:45mm
 Fan accessories

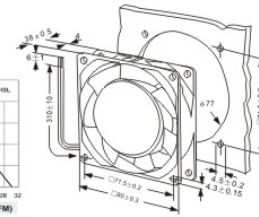
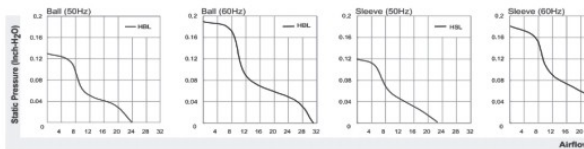
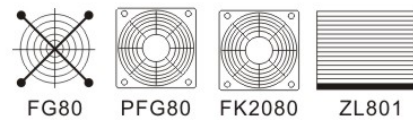

Factory Code	Model	Voltage (V)	Current (A)	Freq (HZ)	Noise (Db)	Bearing	Power (Watt)	Speed (r/min)	Air volume		connector	Packing		
									(m3/h)	CFM		pcs/ctn	weight	dimension
AF838S11L	DS8038ASHL	110	0.14	50/60	32	sleeve	14	2550	40	30	wire	60	16kg	40*40*20
AF838B11L	DS8038ABHL	110	0.14	50/60	32	ball	14	2600	42	31	wire	60	16kg	40*40*20
AF838S11T	DS8038ASHT	110	0.14	50/60	32	sleeve	14	2550	40	30	terminal	60	16kg	40*40*20
AF838B11T	DS8038ABHT	110	0.14	50/60	32	ball	14	2600	42	31	terminal	60	16kg	40*40*20
AF838S22L	DS8038ASHL	220	0.09	50/60	32	sleeve	17	2550	40	30	wire	60	16kg	40*40*20
AF838B22L	DS8038ABHL	220	0.09	50/60	32	ball	17	2600	42	31	wire	60	16kg	40*40*20
AF838S22T	DS8038ASHT	220	0.09	50/60	32	sleeve	17	2550	40	30	terminal	60	16kg	40*40*20
AF838B22T	DS8038ABHT	220	0.09	50/60	32	ball	17	2600	42	31	terminal	60	16kg	40*40*20
AF838SBIVL	DS8038ASHL	110&220	0.09/0.14	50/60	32	sleeve	17	2550	40	30	wire	60	16kg	40*40*20
AF838BIVL	DS8038ABHL	110&220	0.09/0.14	50/60	32	ball	17	2600	42	31	wire	60	16kg	40*40*20



Size:92x92x25mm
 Impeller material:PBT thermoplastic black UL94-V
 Frame:Aluminum Alloy
 Motor:shaded pole induction motor
 Operation temperature:-10°C~+65°C
 Label diameter: 55mm

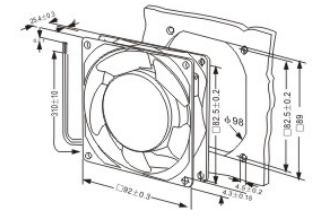
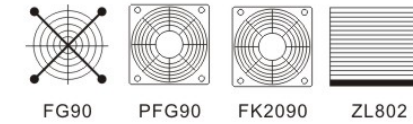

P/N	Model	Voltage (V)	Current (A)	Freq (HZ)	Noise (Db)	Bearing	Power (Watt)	Speed (r/min)	Air volume		connector	Packing		
									(m3/h)	CFM		pcs/ctn	weight	dimension
AF925S11L	DS9225ASHL	110	0.14	50/60	32	sleeve	13	2500	58	35	wire	80	23kg	46*40*22
AF925B11L	DS9225ABHL	110	0.14	50/60	32	ball	14	2550	59	36	wire	80	23kg	46*40*22
AF925S11T	DS9225ASHT	110	0.14	50/60	32	sleeve	13	2500	58	35	terminal	80	23kg	46*40*22
AF925B11T	DS9225ABHT	110	0.14	50/60	32	ball	14	2550	59	36	terminal	80	23kg	46*40*22
AF925S22L	DS9225ASHL	220	0.09	0	32	sleeve	13	2500	58	35	wire	80	23kg	46*40*22
AF925B22L	DS9225ABHL	220	0.09	50/60	32	ball	14	2550	59	36	wire	80	23kg	46*40*22
AF925S22T	DS9225ASHT	220	0.09	50/60	32	sleeve	13	2500	58	35	terminal	80	23kg	46*40*22
AF925B22T	DS9225ABHT	220	0.09	50/60	32	ball	14	2550	59	36	terminal	80	23kg	46*40*22
AF925SBIVL	DS9225ASHL	110&220	0.09/0.14	50/60	32	sleeve	13	2500	58	35	wire	80	23kg	46*40*22
AF925BIVL	DS9225ABHL	110&220	0.09/0.14	50/60	32	ball	14	2550	59	36	wire	80	23kg	46*40*22



Size:92x92x38mm
 Impeller material:PBT thermoplastic black UL94-V
 Frame:Aluminum Alloy
 Motor:shaded pole induction motor
 Operation temperature:-10°C~+65°C
 Label diameter:45mm

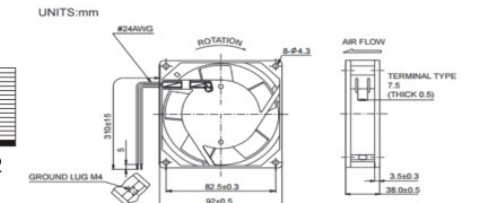
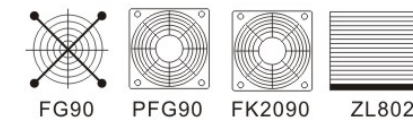

P/N	Model	Voltage (V)	Current (A)	Freq (HZ)	Noise (Db)	Bearing	Power (Watt)	Speed (r/min)	Air volume		connector	Packing		
									(m3/h)	CFM		pcs/ctn	weight	dimension
AF938S11L	DS9238ASHL	110	0.14	50/60	32	sleeve	15	2550	77	46	wire	60	23kg	46*40*22
AF938B11L	DS9238ABHL	110	0.14	50/60	32	ball	15	2600	79	47	wire	60	23kg	46*40*22
AF938S11T	DS9238ASHT	110	0.14	50/60	32	sleeve	15	2550	77	46	terminal	60	23kg	46*40*22
AF938B11T	DS9238ABHT	110	0.14	50/60	32	ball	15	2600	79	47	terminal	60	23kg	46*40*22
AF938S22L	DS9238ASHL	220	0.09	50/60	32	sleeve	15	2550	77	46	wire	60	23kg	46*40*22
AF938B22L	DS9238ABHL	220	0.09	50/60	32	ball	15	2600	79	47	wire	60	23kg	46*40*22
AF938S22T	DS9238ASHT	220	0.09	50/60	32	sleeve	15	2550	77	46	terminal	60	23kg	46*40*22
AF938B22T	DS9238ABHT	220	0.09	50/60	32	ball	15	2600	79	47	terminal	60	23kg	46*40*22
AF938SBIVL	DS9238ASHL	110&220	0.09/0.14	50/60	32	sleeve	16	2550	77	46	wire	60	23kg	46*40*22
AF938BIVL	DS9238ABHL	110&220	0.09/0.14	50/60	32	ball	16	2600	79	47	wire	60	23kg	46*40*22



Size: 110x110x25mm
 Impeller material: PBT thermoplastic black UL94-V
 Frame: Aluminum Alloy
 Motor: shaded pole induction motor
 Operation temperature: -10°C~+65°C
 Label diameter: 57mm

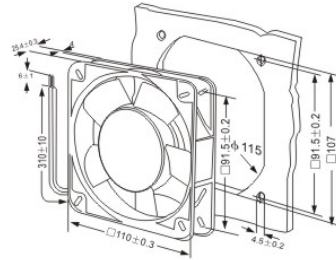
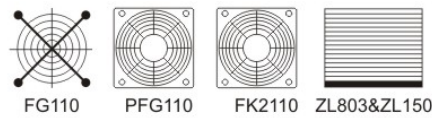

P/N	Model	Voltage (V)	Current (A)	Freq (HZ)	Noise (Db)	Bearing	Power (Watt)	Speed (r/min)	Air volume		connector	Packing		
									(m ³ /h)	CFM		pcs/ctn	weight	dimension
AF1125S11L	DS11025ASHL	110	0.16	50/60	32	sleeve	14	2500	78	47	wire	80	20kg	53*40*26
AF1125B11L	DS11025ABHL	110	0.16	50/60	32	ball	15	2550	80	48	terminal	80	20kg	53*40*26
AF1125S11T	DS11025ASHT	110	0.16	50/60	32	sleeve	14	2500	78	47		80	20kg	53*40*26
AF1125B11T	DS11025ABHT	110	0.16	50/60	32	ball	15	2550	80	48	wire	80	20kg	53*40*26
AF1125S22L	DS11025ASHL	220	0.08	50/60	32	sleeve	14	2500	78	47		80	20kg	53*40*26
AF1125B22L	DS11025ABHL	220	0.08	50/60	32	ball	15	2550	80	48	terminal	80	20kg	53*40*26
AF1125S22T	DS11025ASHT	220	0.08	50/60	32	sleeve	14	2500	78	47		80	20kg	53*40*26
AF1125B22T	DS11025ABHT	220	0.08	50/60	32	ball	15	2550	80	48	wire	80	20kg	53*40*26
AF1125SBIVL	DS11025ASHL	110&220	0.08/0.16	50/60	32	sleeve	14	2500	78	47		80	20kg	53*40*26
AF11252BIVL	DS11025ABHL	110&220	0.08/0.16	50/60	32	ball	15	2550	80	48	80	20kg	53*40*26	



Size: 120x120x38mm
 Impeller material: PBT thermoplastic black UL94-V
 Frame: Aluminum Alloy
 Motor: shaded pole induction motor
 Operation temperature: -10°C~+65°C
 Label diameter: 60mm

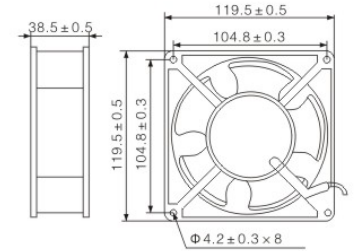
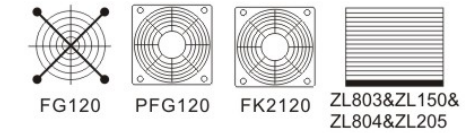

P/N	Model	Voltage (V)	Current (A)	Freq (HZ)	Noise (Db)	Bearing	Power (Watt)	Speed (r/min)	Air volume		connector	Packing		
									(m ³ /h)	CFM		pcs/ctn	weight	dimension
AF1238S11L	DS12038ASHL	110	0.22	50/60	39	sleeve	19	2500	138	81	wire	40	19kg	51*29.5*29
AF1238B11L	DS12038ABHL	110	0.22	50/60	39	ball	20	2550	148	87	terminal	40	19kg	51*29.5*29
AF1238S11T	DS12038ASHT	110	0.22	50/60	39	sleeve	19	2500	138	81		40	19kg	51*29.5*29
AF1238B11T	DS12038ABHT	110	0.22	50/60	39	ball	20	2550	148	87	wire	40	19kg	51*29.5*29
AF1238S22L	DS12038ASHL	220	0.11	50/60	39	sleeve	19	2500	138	81		40	19kg	51*29.5*29
AF1238B22L	DS12038ABHL	220	0.11	50/60	39	ball	20	2550	148	87	terminal	40	19kg	51*29.5*29
AF1238S22T	DS12038ASHT	220	0.11	50/60	39	sleeve	19	2500	138	81		40	19kg	51*29.5*29
AF1238B22T	DS12038ABHT	220	0.11	50/60	39	ball	20	2550	148	87	wire	40	19kg	51*29.5*29
AF1238S38L	DS12038ASHL	380	0.06	50/60	39	sleeve	19	2500	138	81		40	19kg	51*29.5*29
AF1238B38L	DS12038ABHL	380	0.06	50/60	39	ball	20	2550	148	87	wire	40	19kg	51*29.5*29
AF1238S38T	DS12038ASHT	380	0.06	50/60	39	sleeve	19	2500	138	81		40	19kg	51*29.5*29
AF1238B38T	DS12038ABHT	380	0.06	50/60	39	ball	20	2550	148	87	wire	40	19kg	51*29.5*29
AF1238SBIVL	DS12038ASHL	110&220	0.11/0.22	50/60	39	sleeve	19	2500	138	81		40	19kg	51*29.5*29
AF12382BIVL	DS12038ABHL	110&220	0.11/0.22	50/60	39	ball	20	2550	148	87	40	19kg	51*29.5*29	



Size: 120x120x25mm
 Impeller material: PBT thermoplastic black UL94-V
 Frame: Aluminum Alloy
 Motor: shaded pole induction motor
 Operation temperature: -10°C~+65°C
 Label diameter: 57mm

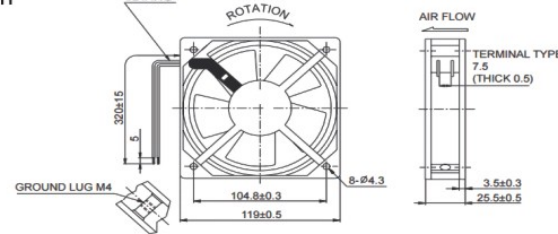
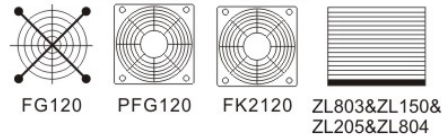

P/N	Model	Voltage (V)	Current (A)	Freq (HZ)	Noise (Db)	Bearing	Power (Watt)	Speed (r/min)	Air volume		connector	Packing		
									(m ³ /h)	CFM		pcs/ctn	weight	dimension
AF1225S11L	DS12025ASHL	110	0.16	50/60	32	sleeve	15	2550	85	50	wire	60	21kg	44*40*28
AF1225B11L	DS12025ABHL	110	0.16	50/60	32	ball	15	2600	90	53	terminal	60	21kg	44*40*28
AF1225S11T	DS12025ASHT	110	0.16	50/60	32	sleeve	15	2550	85	50		60	21kg	44*40*28
AF1225B11T	DS12025ABHT	110	0.16	50/60	32	ball	15	2600	90	53	wire	60	21kg	44*40*28
AF1225S22L	DS12025ASHL	220	0.08	50/60	32	sleeve	15	2550	85	50		60	21kg	44*40*28
AF1225B22L	DS12025ABHL	220	0.08	50/60	32	ball	15	2600	90	53	terminal	60	21kg	44*40*28
AF1225S22T	DS12025ASHT	220	0.08	50/60	32	sleeve	15	2550	85	50		60	21kg	44*40*28
AF1225B22T	DS12025ABHT	220	0.08	50/60	32	ball	15	2600	90	53	wire	60	21kg	44*40*28
AF1225SBIVL	DS12025ASHL	110&220	0.08/0.16	50/60	32	sleeve	16	2550	85	50		60	21kg	44*40*28
AF12252BIVL	DS12025ABHL	110&220	0.08/0.16	50/60	32	ball	16	2600	90	53	60	21kg	44*40*28	



Size: 120x120x38mm
 Impeller material: PBT thermoplastic black UL94-V
 Frame: Aluminum Alloy
 Motor: shaded pole induction motor
 Operation temperature: -10°C~+65°C
 Label diameter: 45mm

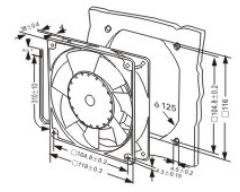
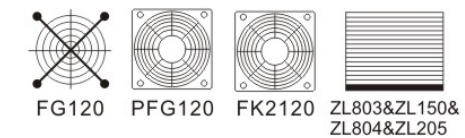

P/N	Model	Voltage (V)	Current (A)	Freq (HZ)	Noise (Db)	Bearing	Power (Watt)	Speed (r/min)	Air volume		connector	Packing		
									(m ³ /h)	CFM		pcs/ctn	weight	dimension
AF12387S11L	DS12038ASHL	110	0.24	50/60	43	sleeve	21	2580	160	94	wire	40	22kg	46*28*28
AF12387B11L	DS12038ABHL	110	0.24	50/60	43	ball	22	2700	172	102	terminal	40	22kg	46*28*28
AF12387S11T	DS12038ASHT	110	0.24	50/60	43	sleeve	21	2580	160	94		40	22kg	46*28*28
AF12387B11T	DS12038ABHT	110	0.24	50/60	43	ball	22	2700	172	102	wire	40	22kg	46*28*28
AF12387S22L	DS12038ASHL	220	0.12	50/60	43	sleeve	21	2580	160	94		40	22kg	46*28*28
AF12387B22L	DS12038ABHL	220	0.12	50/60	43	ball	22	2700	172	102	terminal	40	22kg	46*28*28
AF12387S22T	DS12038ASHT	220	0.12	50/60	43	sleeve	21	2580	160	94		40	22kg	46*28*28
AF12387B22T	DS12038ABHT	220	0.12	50/60	43	ball	22	2700	172	102	wire	40	22kg	46*28*28
AF12387S38L	DS12038ASHL	380	0.07	50/60	43	sleeve	21	2580	160	94		40	22kg	46*28*28
AF12387B38L	DS12038ABHL	380	0.07	50/60	43	ball	22	2700	172	102	wire	40	22kg	46*28*28
AF12387S38T	DS12038ASHT	380	0.07	50/60	43	sleeve	21	2580	160	94		40	22kg	46*28*28
AF12387B38T	DS12038ABHT	380	0.07	50/60	43	ball	22	2700	172	102	wire	40	22kg	46*28*28
AF12387SBIVL	DS12038ASHL	110&220	0.12/0.24	50/60	43	sleeve	21	2580	160	94		40	22kg	46*28*28
AF123872BIVL	DS12038ABHL	110&220	0.12/0.24	50/60	43	ball	22	2700	172	102	40	22kg	46*28*28	

Size: 135x135x32mm
 Impeller material: PBT thermoplastic black UL94-V
 Frame: Aluminum Alloy
 Motor: shaded pole induction motor
 Operation temperature: -10°C ~ +65°C
 Label diameter: 45mm

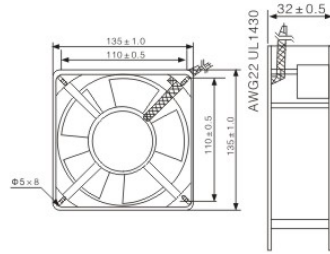
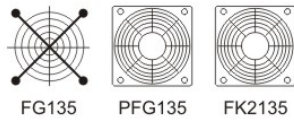

P/N	Model	Voltage (V)	Current (A)	Freq (HZ)	Noise (Db)	Bearing	Power (Watt)	Speed (r/min)	Air volume		connector	Packing		
									(m3/h)	CFM		pcs/ctn	weight	dimension
AF13532S11L	125FZY1-S	110	0.28	50/60	45	sleeve	25	2500	168	98	wire	40	24kg	37*29.5*30
AF13532B11L	125FZY1-S	110	0.28	50/60	45	ball	25	2550	180	105		40	24kg	37*29.5*30
AF13532S22L	125FZY2-S	220	0.14	50/60	45	sleeve	25	2500	168	98		40	24kg	37*29.5*30
AF13532B22L	125FZY2-S	220	0.14	50/60	45	ball	25	2550	180	105		40	24kg	37*29.5*30
AF13532S38L	125FZY4-S	380	0.08	50/60	45	sleeve	25	2500	168	98		40	24kg	37*29.5*30
AF13532B38L	125FZY4-S	380	0.08	50/60	45	ball	25	2550	180	105		40	24kg	37*29.5*30

Size: 172x150x38mm
 Impeller material: PBT thermoplastic black UL94-V
 Frame: Aluminum Alloy
 Motor: shaded pole induction motor
 Operation temperature: -10°C ~ +65°C
 Label diameter: 45mm

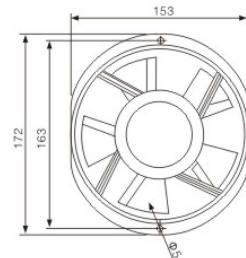
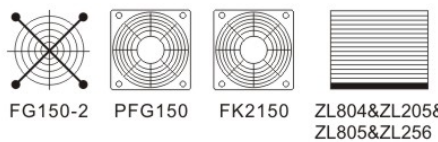

P/N	Model	Voltage (V)	Current (A)	Freq (HZ)	Noise (Db)	Bearing	Power (Watt)	Speed (r/min)	Air volume		connector	Packing		
									(m3/h)	CFM		pcs/ctn	weight	dimension
AF17238B11L	145FZY1-S	110	0.36	50/60	52	sleeve	30w	2500	312	183	wire	20	18kg	37*33*26.5
AF17238B11T	145FZY1-S	110	0.36	50/60	52	ball	30w	2550	320	188	terminal	20	18kg	37*33*26.5
AF17238B22L	145FZY2-S	220	0.18	50/60	52	sleeve	30w	2500	312	183	wire	20	18kg	37*33*26.5
AF17238B22T	145FZY2-S	220	0.18	50/60	52	ball	30w	2550	320	188	terminal	20	18kg	37*33*26.5
AF17238B38L	145FZY4-S	380	0.1	50/60	52	sleeve	30w	2500	312	183	wire	20	18kg	37*33*26.5
AF17238B38T	145FZY4-S	380	0.1	50/60	52	ball	30w	2550	320	188	terminal	20	18kg	37*33*26.5

Size: 172x150x51mm
 Impeller material: PBT thermoplastic black UL94-V
 Frame: Aluminum Alloy
 Motor: shaded pole induction motor
 Operation temperature: -10°C ~ +65°C
 Label diameter: 53mm

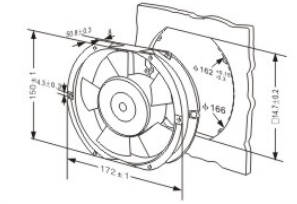
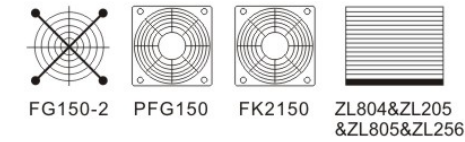

P/N	Model	Voltage (V)	Current (A)	Freq (HZ)	Noise (Db)	Bearing	Power (Watt)	Speed (r/min)	Air volume		connector	Packing		
									(m3/h)	CFM		pcs/ctn	weight	dimension
AF1725S11L	DS15052ASHL	110	0.4	50/60	50	sleeve	26w	2500	298	175	wire	20	18kg	37.5*33*31
AF1725B11L	DS15052ABHL	110	0.4	50/60	50	ball	26w	2650	330	194		20	18kg	37.5*33*31
AF1725S11T	DS15052ASHT	110	0.4	50/60	50	sleeve	26w	2500	298	175	terminal	20	18kg	37.5*33*31
AF1725B11T	DS15052ABHT	110	0.4	50/60	50	ball	26w	2650	330	194		20	18kg	37.5*33*31
AF1725S22L	DS15052ASHL	220	0.2	50/60	50	sleeve	26w	2500	298	175	wire	20	18kg	37.5*33*31
AF1725B22L	DS15052ABHL	220	0.2	50/60	50	ball	26w	2650	330	194		20	18kg	37.5*33*31
AF1725S22T	DS15052ASHT	220	0.2	50/60	50	sleeve	26w	2500	298	175	terminal	20	18kg	37.5*33*31
AF1725B22T	DS15052ABHT	220	0.2	50/60	50	ball	26w	2650	330	194		20	18kg	37.5*33*31
AF1725S38L	DS15052ASHL	380	0.12	50/60	50	sleeve	26w	2500	298	175	wire	20	18kg	37.5*33*31
AF1725B38L	DS15052ABHL	380	0.12	50/60	50	ball	26w	2650	330	194		20	18kg	37.5*33*31
AF1725S38T	DS15052ASHT	380	0.12	50/60	50	sleeve	26w	2500	298	175	terminal	20	18kg	37.5*33*31
AF1725B38T	DS15052ABHT	380	0.12	50/60	50	ball	26w	2650	330	194		20	18kg	37.5*33*31

Size: 150x150x51mm
 Impeller material: PBT thermoplastic black UL94-V
 Frame: Aluminum Alloy
 Motor: shaded pole induction motor
 Operation temperature: -10°C ~ +65°C
 Label diameter: 53mm

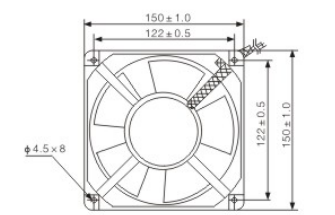
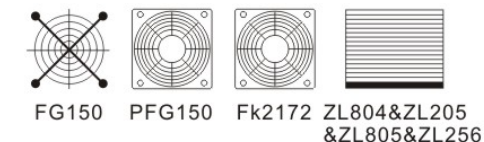

P/N	Model	Voltage (V)	Current (A)	Freq (HZ)	Noise (Db)	Bearing	Power (Watt)	Speed (r/min)	Air volume		connector	Packing		
									(m3/h)	CFM		pcs/ctn	weight	dimension
AF1551S11L	DS15051ASHL	110	0.4	50/60	50	sleeve	25	2500	298	175	wire	20	18kg	33*29*33.5
AF1551B11L	DS15051ABHL	110	0.4	50/60	50	ball	30	2650	330	194		20	18kg	33*29*33.5
AF1551S11T	DS15051ASHT	110	0.4	50/60	50	sleeve	25	2500	298	175	terminal	20	18kg	33*29*33.5
AF1551B11T	DS15051ABHT	110	0.4	50/60	50	ball	30	2650	330	194		20	18kg	33*29*33.5
AF1551S22L	DS15051ASHL	220	0.2	50/60	50	sleeve	25	2500	298	175	wire	20	18kg	33*29*33.5
AF1551B22L	DS15051ABHL	220	0.2	50/60	50	ball	30	2650	330	194		20	18kg	33*29*33.5
AF1551S22T	DS15051ASHT	220	0.2	50/60	50	sleeve	25	2500	298	175	terminal	20	18kg	33*29*33.5
AF1551B22T	DS15051ABHT	220	0.2	50/60	50	ball	30	2650	330	194		20	18kg	33*29*33.5
AF1551S38L	DS15051ASHL	380	0.12	50/60	50	sleeve	25	2500	298	175	wire	20	18kg	33*29*33.5
AF1551B38L	DS15051ABHL	380	0.12	50/60	50	ball	30	2650	330	194		20	18kg	33*29*33.5
AF1551S38T	DS15051ASHT	380	0.12	50/60	50	sleeve	25	2500	298	175	terminal	20	18kg	33*29*33.5
AF1551B38T	DS15051ABHT	380	0.12	50/60	50	ball	30	2650	330	194		20	18kg	33*29*33.5



Size:172x172x51mm
 Impeller material:PBT thermoplastic black UL94-V
 Frame:Aluminum Alloy
 Motor:shaded pole induction motor
 Operation temperature:-10°C~+65°C
 Label diameter:53mm

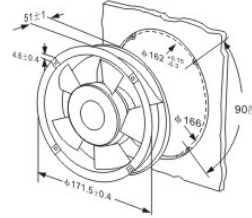
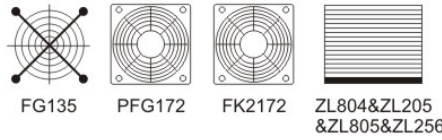

P/N	Model	Voltage (V)	Current (A)	Freq (HZ)	Noise (Db)	Bearing	Power (Watt)	Speed (r/min)	Air volume		connector	Packing		
									(m3/h)	CFM		pcs/ctn	weight	dimension
AF172RS11L	DS1752ASHL	110	0.4	50/60	50	sleeve	25	2500	298	175	wire	20	17kg	38*37*31
AF172RB11L	DS1752ABHL	110	0.4	50/60	50	ball	30	2650	330	194	wire	20	17kg	38*37*31
AF172RS11T	DS1752ASHT	110	0.4	50/60	50	sleeve	25	2500	298	175	terminal	20	17kg	38*37*31
AF172RB11T	DS1752ABHT	110	0.4	50/60	50	ball	30	2650	330	194	terminal	20	17kg	38*37*31
AF172RS22L	DS1752ASHL	220	0.2	50/60	50	sleeve	25	2500	298	175	wire	20	17kg	38*37*31
AF172RB22L	DS1752ABHL	220	0.2	50/60	50	ball	30	2650	330	194	wire	20	17kg	38*37*31
AF172RS22T	DS1752ASHT	220	0.2	50/60	50	sleeve	25	2500	298	175	terminal	20	17kg	38*37*31
AF172RB22T	DS1752ABHT	220	0.2	50/60	50	ball	30	2650	330	194	terminal	20	17kg	38*37*31
AF172RS38L	DS1752ASHL	380	0.12	50/60	50	sleeve	25	2500	298	175	wire	20	17kg	38*37*31
AF172RB38L	DS1752ABHL	380	0.12	50/60	50	ball	30	2650	330	194	wire	20	17kg	38*37*31
AF172RS38T	DS1752ASHT	380	0.12	50/60	50	sleeve	25	2500	298	175	terminal	20	17kg	38*37*31
AF172RB38T	DS1752ABHT	380	0.12	50/60	50	ball	30	2650	330	194	terminal	20	17kg	38*37*31

Size:180x180x60mm
 Impeller material:PBT thermoplastic black UL94-V
 Frame:Aluminum Alloy
 Motor:shaded pole induction motor
 Operation temperature:-10°C~+65°C
 Label diameter:65mm

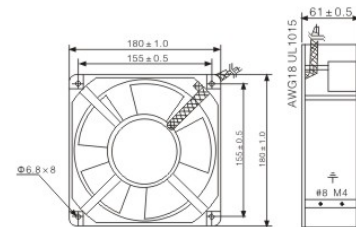
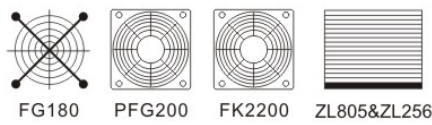

P/N	Model	Voltage (V)	Current (A)	Freq (HZ)	Noise (Db)	Bearing	Power (Watt)	Speed (r/min)	Air volume		connector	Packing		
									(m3/h)	CFM		pcs/ctn	weight	dimension
AF1860B11L	DS18060ABHL	110	0.7	50	60	ball	60	2650	618	363	WIRE	10	17kg	40*21*37
AF1860B22L	DS18060ABHL	220	0.375	50	60	ball	60	2650	618	363	WIRE	10	17kg	40*21*37
AF1860B38L	DS18060ABHL	380	0.215	50	60	ball	60	2650	618	363	WIRE	10	17kg	40*21*37



Size:200x200x60mm
 Impeller material:PBT thermoplastic black UL94-V
 Frame:Aluminum Alloy
 Motor:shaded pole induction motor
 Operation temperature:-10°C~+65°C
 Label diameter:65mm

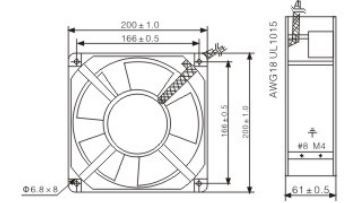
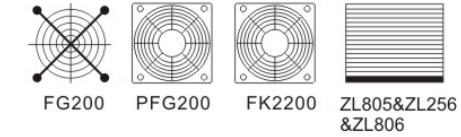

P/N	Model	Voltage (V)	Current (A)	Freq (HZ)	Noise (Db)	Bearing	Power (Watt)	Speed (r/min)	Air volume		connector	Packing		
									(m3/h)	CFM		pcs/ctn	weight	dimension
AF2060B11L	DS20060ABHL	110	0.78	50	65	ball	65	2550	680	400	WIRE	10	18kg	47*24*47.2
AF2060B22L	DS20060ABHL	220	0.4	50	65	ball	65	2550	680	400	WIRE	10	18kg	47*24*47.2
AF2060B38L	DS20060ABHL	380	0.24	50	65	ball	65	2550	680	400	WIRE	10	18kg	47*24*47.2

Size:220x220x60mm
 Impeller material:PBT thermoplastic black UL94-V
 Frame:Aluminum Alloy
 Motor:shaded pole induction motor
 Operation temperature:-10°C~+65°C
 Label diameter:70mm

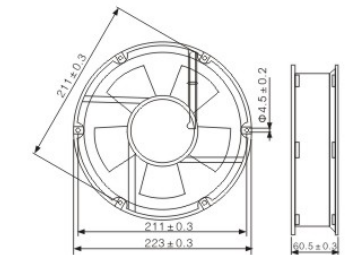
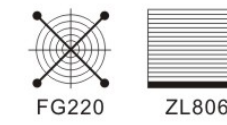

P/N	Model	Voltage (V)	Current (A)	Freq (HZ)	Noise (Db)	Bearing	Power (Watt)	Speed (r/min)	Air volume		connector	Packing		
									(m3/h)	CFM		pcs/ctn	weight	dimension
AF2260B11L	DS22060ABHL	110	0.6	50	60	ball	50	2450	509	509	WIRE	10	21kg	50*48*26
AF2260B22L	DS22060ABHL	220	0.33	50	60	ball	50	2450	509	509	WIRE	10	21kg	50*48*26
AF2260B38L	DS22060ABHL	380	0.2	50	60	ball	50	2450	509	509	WIRE	10	21kg	50*48*26



Size:230x230x65mm
 Impeller material:PBT thermoplastic black UL94-V
 Frame:Aluminum Alloy
 Motor:shaded pole induction motor
 Operation temperature:-10°C~+65°C
 Label diameter:70mm

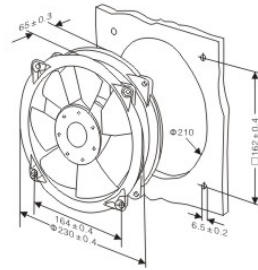
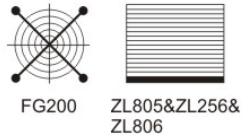

P/N	Model	Voltage (V)	Current (A)	Freq (HZ)	Noise (Db)	Bearing	Power		Air volume		connector
							(Watt)	(r/min)	(m3/h)	CFM	
AF2365B11L	DS23065ABHL	110	0.78	50	65	ball	65	2500	476	280	WIRE
AF2365B22L	DS23065ABHL	220	0.4	50	65	ball	65	2500	476	280	WIRE
AF2365B38L	DS23065ABHL	380	0.24	50	65	ball	65	2500	476	280	WIRE



Size:107x100x30mm
 Impeller material:PBT thermoplastic black UL94-V
 Frame:Aluminum Alloy
 Motor:shaded pole induction motor
 Operation temperature:-10 65
 Label diameter:45mm

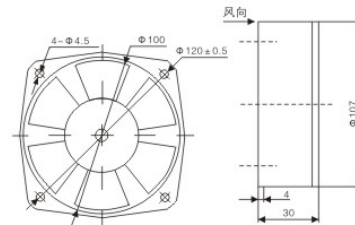

P/N	Model	Voltage (V)	Current (A)	Freq (HZ)	Noise (Db)	Bearing	Power		Air volume		connector
							(Watt)	(r/min)	(m3/h)	CFM	
AF100FS11L	100FZY1-D	110	0.14	50/60	32	sleeve	23w	2500	78	47	WIRE
AF100FS22L	100FZY2-D	220	0.07	50/60	32	sleeve	23w	2500	78	47	WIRE



Size:160x160x60mm
 Impeller material:PBT thermoplastic black UL94-V
 Frame:Aluminum Alloy
 Motor:shaded pole induction motor
 Operation temperature:-10°C~+65°C
 Label diameter:65*30mm

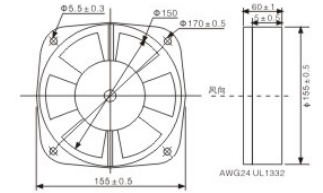
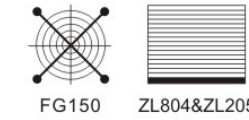

P/N	Model	Voltage (V)	Current (A)	Freq (HZ)	Noise (Db)	Bearing	Power (Watt)	Speed (r/min)	Air volume		connector	Packing		
									(m3/h)	CFM		pcs/ctn	weight	dimension
AF15F11L	150FZY1-D	110	0.25	50/60	62	Ball bearing	30	2550	340	200	wire	20	17kg	34.5*34.5*35
AF15F22L	150FZY2-D	220	0.137	50/60	62		30	2550	340	200		20	17kg	34.5*34.5*35
AF15F38L	150FZY4-D 380 three phase	380	0.137	50	62		30	2550	340	200		20	17kg	34.5*34.5*35
AF15F387L	150FZY7-D 380 single phase	380	0.09	50	32		30	2550	340	200		20	17kg	34.5*34.5*35



Size:210*210*70mm
 Impeller material:PBT thermoplastic black UL94-V
 Frame:Aluminum Alloy
 Motor:shaded pole induction motor
 Operation temperature:-10°C~+65°C
 Label diameter:44mm

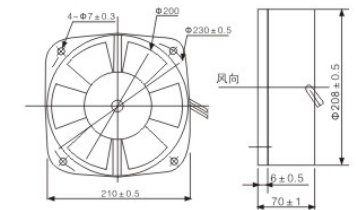
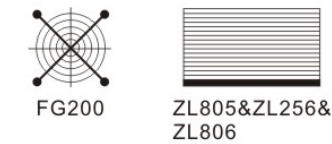

P/N	Model	Voltage (V)	Current (A)	Freq (HZ)	Noise (Db)	Bearing	Power (Watt)	Speed (r/min)	Air volume		connector	Packing		
									(m3/h)	CFM		pcs/ctn	weight	dimension
AF20F11L	200FZY1-D	110	0.4	50/60	67	Ball bearing	65	2550	790	465	WIRE	10	15kg	45.5*23*42
AF20F22L	200FZY2-D	220	0.2	50	67		65	2550	790	465		10	15kg	45.5*23*42
AF20F22L6H	200FZY2-D	220	0.17	60	65		60	2450	750	440		10	15kg	45.5*23*42
AF20F38L4	200FZY4-D 380 three phase	380	0.1	50	67		65	2550	790	465		10	15kg	45.5*23*42
AF20F38L7	200FZY7-D 380 single phase	380	0.1	50	67		65	2550	790	465		10	15kg	45.5*23*42

Size:172x150x51mm
 Impeller material: Metal
 Frame:Aluminum Alloy
 Motor:shaded pole induction motor
 Operation temperature:-10°C~+65°C
 Label diameter:53mm

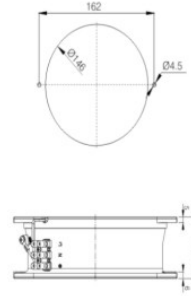
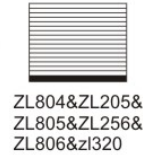
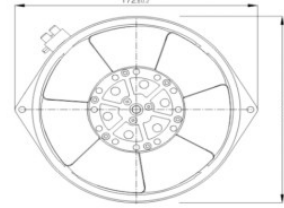
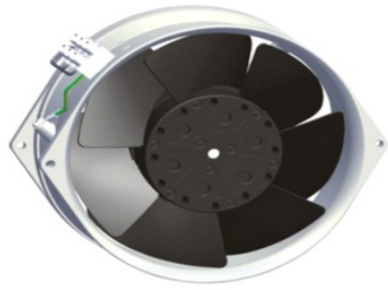

P/N	Model	Voltage (V)	Current (A)	Freq (HZ)	Noise (Db)	Bearing	Power (Watt)	Speed (r/min)	Air volume		connector	Packing		
									(m3/h)	CFM		pcs/ctn	weight	dimension
AF160M11L	DS16055MAB	110	0.52	50	49	ball	37	2650	320	189	WIRE	10	24kg	51*26.5*56
AF160M11L60	DS16055MAB		0.43	60	53		34	3000	380	224		10	24kg	
AF160M22L	DS16055MAB	220V	0.25	50	49		37	2650	320	189		10	24kg	
AF160M22L60	DS16055MAB		0.2	60	53		34	3000	380	224		10	24kg	
AF160M38L	DS16055MAB	380V	0.15	50	49		37	2650	320	189		10	24kg	
AF160M38L60	DS16055MAB		0.12	60	53		34	3000	380	224		10	24kg	



Size:225x225x80mm
 Impeller material: Metal
 Frame:Aluminum Alloy
 Motor:shaded pole induction motor
 Operation temperature:-10°C~+65°C
 Label diameter: 70mm

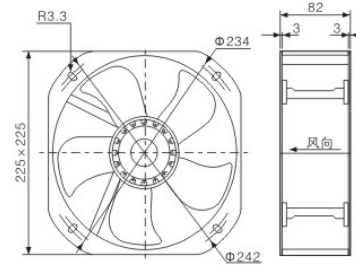
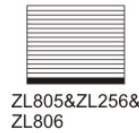

P/N	Model	Voltage (V)	Current (A)	Freq (HZ)	Noise (Db)	Bearing	Power (Watt)	Speed (r/min)	Air volume		connector	Packing		
									(m3/h)	CFM		pcs/ctn	weight	dimension
AF225F11L	200FZY1-S	110	0.7	50	75	ball	80	2400	1200	705	WIRE	10	24kg	51*26.5*56
AF225F11L60F	200FZY1-S		1.04	60	75	ball	105	2400	1200	705		10	24kg	
AF225F22L	200FZY2-S	220	0.18	50	65	ball	40	1250	720	425		10	24kg	
AF225F22LH6	200FZY6-S		0.54	50	75	ball	110	2500	1300	764		10	24kg	
AF225F22H6F6	200FZY6-S	0.5	60	75	ball	105	2600	1300	764	10		24kg		
AF225F38L3	200FZY3-S	380 three phase	0.1	50	75	ball	40	1250	720	425		10	24kg	
AF225F38L4	200FZY4-S		380 single phase	0.1	50	75	ball	40	1250	720		425	10	
AF225F11LH7	200FZY7-S	380 three phase	0.23	50	75	ball	110	2500	1300	764		10	24kg	
AF225F11LH8	200FZY8-S		380 single phase	0.23	50	75	ball	110	2500	1300		764	10	

Size:225x225x80mm
 Impeller material: Metal
 Frame:Aluminum Alloy
 Motor:shaded pole induction motor
 Operation temperature:-10°C~+65°C
 Label diameter:70mm

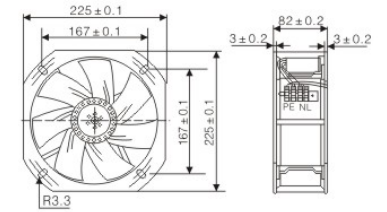
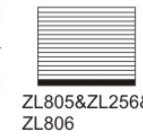

P/N	Model	Voltage (V)	Current (A)	Freq (HZ)	Noise (Db)	Bearing	Power (Watt)	Speed (r/min)	Air volume		connector	Packing		
									(m3/h)	CFM		pcs/ctn	weight	dimension
AF225F9L11	DS22580ABHL	110	0.68	50	69	ball	105	2520	1150	676	WIRE	10	24kg	51*26.5*56
AF225F911F60	DS22580ABHL	110	0.68	60	69	ball	105	2520	1150	676		10	24kg	
AF225F9L22	DS22580ABHL	220	0.54	50	69	ball	105	2520	1150	676		10	24kg	
AF225F922F60	DS22580ABHL	220	0.5	60	69	ball	105	2520	1150	676		10	24kg	
AF225F9L38	DS22580ABHL	380	0.23	50	69	ball	105	2520	1150	676		10	24kg	



Size:280x280x80mm
 Impeller material: Metal
 Frame:Aluminum Alloy
 Motor:shaded pole induction motor
 Operation temperature:-10°C~+65°C
 Label diameter: 70mm

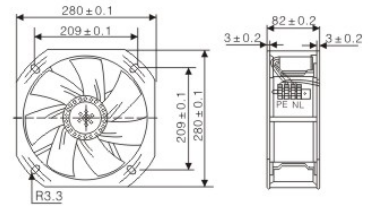
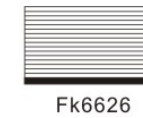

P/N	Model	Voltage (V)	Current (A)	Freq (HZ)	Noise (Db)	Bearing	Power (Watt)	Speed (r/min)	Air volume		connector	Packing		
									(m3/h)	CFM		pcs/ctn	weight	dimension
AF280FL11	DS28083ABHL	110	0.7	50	69	ball	115	2400	1800	1060	WIRE	10	14kg	54.5*33*36
AF280F11F60	DS28083ABHL	110	0.7	60	69	ball	115	2400	1800	1060		10	14kg	
AF280FL22	DS28083ABHL	220	0.5	50	69	ball	115	2400	1800	1060		10	14kg	
AF280F22F60	DS28083ABHL	220	0.5	60	69	ball	115	2400	1800	1060		10	14kg	
AF280FL38	DS28083ABHL	380	0.23	50	69	ball	115	2400	1800	1060		10	14kg	

Size:250x410x90mm
 Impeller material: Metal
 Frame: Aluminum Alloy
 Motor: shaded pole induction motor
 Operation temperature: -10°C~+65°C

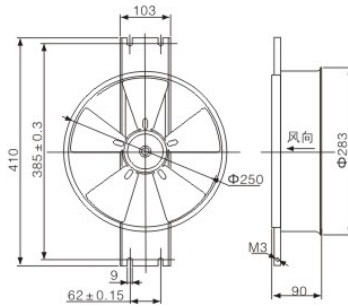

P/N	Model	Voltage (V)	Current (A)	Freq (HZ)	Noise (Db)	Bearing	Power (Watt)	Speed (r/min)	Air volume		connector	Packing		
									(m3/h)	CFM		pcs/ctn	weight	dimension
AF250R11	250FZY1-D	110	0.36	50	60	ball	40	1300	633	376	1	5	15kg	56*43*31
AF250R11F60	250FZY1-D	110	0.36	60	60	ball	40	1300	633	376	1	5	15kg	56*43*31
AF250R22	250FZY2-D	220	0.36	50	60	ball	40	1300	633	376	1	5	15kg	56*43*31
AF250R22F60	250FZY2-D	220	0.36	60	60	ball	40	1300	633	376	1	5	15kg	56*43*31
AF250R383	250FZY3-D	380	0.1	50	60	ball	40	1300	633	376	3	5	15kg	56*43*31
AF250R384	250FZY4-D	380	0.1	50	60	ball	40	1300	633	376	1	5	15kg	56*43*31
AF250R22H6	250FZY6-D	220V	0.55	50	72	ball	110	2550	1266	753	1	5	15kg	56*43*31
AF250R22H6F60	250FZY6-D	220V	0.55	50	72	ball	110	2550	1266	753	1	5	15kg	56*43*31
AF250R38H7	250FZY7-D	380V	0.2	50	72	ball	110	2550	1266	753	3	5	15kg	56*43*31
AF250R38H8	250FZY8-D	380V	0.2	50	72	ball	110	2550	1266	753	1	5	15kg	56*43*31

Size:300x460x100mm
 Impeller material: Metal
 Frame: Aluminum Alloy
 Motor: shaded pole induction motor
 Operation temperature: -10°C~+65°C

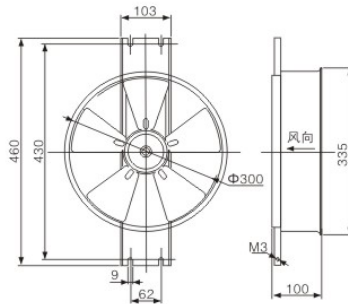

P/N	Model	Voltage (V)	Current (A)	Freq (HZ)	Noise (Db)	Bearing	Power (Watt)	Speed (r/min)	Air volume		connector	Packing		
									(m3/h)	CFM		terminal	pcs/ctn	weight
AF300R11	300FZY1-D	110	0.8	50	60	ball	80	1300	1137	668	terminal	5	18kg	60*47*36
AF300R11F60	300FZY1-D	110	0.8	60	60	ball	80	1300	1137	668		5	18kg	60*47*36
AF300R22	300FZY2-D	220	0.4	50	60	ball	80	1300	1137	668		5	18kg	60*47*36
AF300R22F60	300FZY2-D	220	0.4	60	60	ball	80	1300	1137	668		5	18kg	60*47*36
AF300R383	300FZY3-D	380	0.2	50	60	ball	80	1300	1137	668		5	18kg	60*47*36
AF300R384	300FZY4-D	380	0.2	50	60	ball	80	1300	1137	668		5	18kg	60*47*36
AF300R22H6	300FZY6-D	220V	1.9	50	72	ball	160	2550	2200	1294		5	18kg	60*47*36
AF300R22H6F60	300FZY6-D	220V	0.95	50	72	ball	160	2550	2200	1294		5	18kg	60*47*36
AF300R38H7	300FZY7-D	380V	0.35	50	72	ball	160	2550	2200	1294		5	18kg	60*47*36
AF300R38H8	300FZY8-D	380V	0.35	50	72	ball	160	2550	2200	1294		5	18kg	60*47*36

Size:395mmx130mm
 Airflow:2100-3120m3/hr
 1235-1836CFM
 Weight:5950g
 Noise:56-65dBA
 Impeller Material: Metal

Frame: Metal
 Terminals:0.5mm
 LeadWire:Teflon 18#UL 1332(Optional)
 Motor:Capacitor-Run Induction Motor
 Operation temperature:-10°C~+105°C

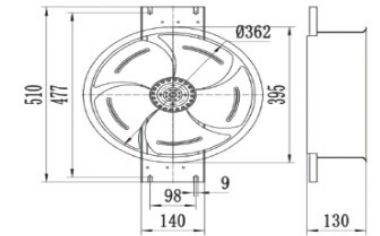

Model	Bearing System	Voltage VAC	Freq.Hz	Current A	Power W	Speed RPM	Noise dBA	Air Flow		Phase	Capacitor
								M3/hr	CFM		
350FZY2-D	Ball	200/240	50/60	0.7	150	1360/1500	62/65	2880-3120	1659/1836	1	4.0uf/500v
350FZY3-D		380/420	50/60	0.35	150	1360/1500	62/65	2880-3120	1659/1836	3	/
350FZY4-D		380/420	50/60	0.4	150	1360/1500	62/65	2880-3120	1659/1836	1	2.2uf/630V

Size: 475mm x 130mm
 Airflow: 3360-4400m3/hr
 1977-2589CFM
 Weight: 6800g
 Noise: 58-70dBA
 Impeller Material: Metal

Frame: Metal
 Terminals:0.5mm
 Lead Wire: Teflon 18#UL 1332(Optional)
 Motor: Capacitor-Run Induction Motor
 Operating Temperature: -10°C~+105°C

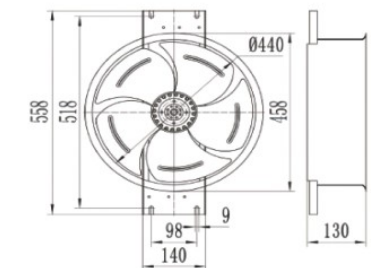

Model	Bearing System	Voltage VAC	Freq.Hz	Current A	Power W	Speed RPM	Noise dBA	Air Flow		Phase	Capacitor
								M3/hr	CFM		
400FZY2-D	Ball	200/240	50/60	0.8	180	1400/1560	68/70	4080/4400	2400/2589	1	6.0uf/500v
400FZY3-D		380/420	50/60	0.4	180	1400/1560	68/70	4080/4400	2400/2589	3	/
400FZY4-D		380/420	50/60	0.45	180	1400/1560	68/70	4080/4400	2400/2589	1	3.0uf/630V