

**Four Screen Four
Display
Automatic Incubator
Controller**

XM-18

Operation Manual

The automatic multi-function incubator researched and produced by our company uses the more popular microcomputer-based technology (using the latest micro-electronics technology and new components), equipping with the imported digital temperature sensor and France moisture sensitive capacitance humidity sensor, which makes this instrument miniaturization, intelligent, high measurement accuracy. This incubator is stable and reliable, time-saving, labor-saving, and easy-to-use. It is the ideal incubation equipment for propagation of poultry and rare birds and small and medium-sized hatchery.

一、 Main Technical Index:

1. Temperature Measuring Range: 0-99°C
2. Temperature Measurement Accuracy: ± 0.1 °C
3. Humidity Measurement Range: 0—99%RH
4. Humidity Accuracy: $\pm 3\%$ RH
5. Number of signal-output: 7, (over-temperature, temperature control, insufficient temperature, egg left-turning, egg right-turning, humidity control, alarm)
6. The maximum output load current: temperature control, insufficient temperature $\leq 8A/AC220V$, over-temperature, egg left-turning, egg right-turning, humidity control, alarm $\leq 1A/AC220$
7. Number of egg-turning: the maximum record is 999 times.
8. cycle of egg-turning: adjustment of 0 - 999 minutes (the factory default is 120 minutes)
9. egg-turning time: adjustment from 0 to 999 seconds (the factory default is 65 seconds)
10. ventilation cycle: from 0 to 999 minutes
(the factory default is 120 minutes)
11. ventilation time: from 0 to 999 seconds (the factory default is 30 seconds)
12. Temperature measurement length: About 2 meters

二、 Working Condition:

1. Working Voltage: AC 180V-240V, 50HZ
2. Relative Humidity: less than 85% RH
3. Environment Temperature: -10°C - 60°C

三、 Temperature and humidity settings instance: This method is very simple, as long as you set up both points of temperature and humidity, others will generate automatically. For example, a incubation control room needs

*	*	*
---	---	---

t	t
---	---

 that the temperature is 38 °C, Humidity is

*	*	*
---	---	---

H	H
---	---

 60% RH. During normal working, press

SET

 and lift your

*	*	*
---	---	---

H	H
---	---

 hand, a row of led will display on the lower side of

*	*	*
---	---	---

H	H
---	---

 the controller. If you need to change the temperature value, press

▲

▼

 to adjust, till to display the temperature 38 °C you required. And then press

OK

 and raise your hand, the led will display on the lower side of the controller. If you need to change the humidity value, please press

▲

▼

 to adjust untill the required humidity 60% RH shows. And then press the key

OK

, the controller will automatically calculate and fill the parameters of temperature and humidity, and finally return to normal working state.

四、 Arbitrary temperature and humidity settings example

(which may change and automatically generate interval, but generally do not use it)

During normal operation, press the key

SET

 and don't raise your hand, and the press the key

▲

 untill display

—	—	—
---	---	---

P	1
---	---

and then raise your hand, set up the following parameters:

✦ Set up over-temperature alarm: led display

*	*	*
---	---	---

P	1
---	---

As shown in right figure: "P1" is the over-temperature alarm value, the alarm will be given if the temperature reaches this value. If any change is needed, please press

▲

▼

 untill it displays the value you required. And press

OK



 and then raise your hand to save data, and automatically move into the next parameter setting.





✦ Set up over-temperature value: led display





*	*	*
---	---	---



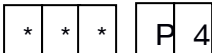

P	2
---	---





as shown in right figure: "P2" is the over-temperature value, the exhaust fan will be started up when the temperature reaches this

value. If any change is needed, please press   until it displays the value you required. And press  and then raise your hand to save data, and automatically move into the next parameter setting.

✦ Set up upper limit value of temperature  control: led display as shown in right figure: "P3" is the upper limit of temperature control. The heating will stop when the Temperature Reaches this value. If any change is needed, please press   until it displays the value you required. And press  and then raise your hand to save data, and automatically move into the next parameter setting.

✦ Set up lower limit value of temperature  control: led display as shown in right figure: "P4" is the lower limit of temperature control. The heating will start up when the temperature droppes to this value. If any change is needed, please press   until it displays the value you required. And press  and then raise your hand to save data, and automatically move into the next parameter setting.

✦ Set up low temperature value: led display as  shown in right figure: "P5" is the low temperature value. The standby heating will start up when the temperature droppes to this value. If any change is needed, please press   until it displays the value you required. And press  and then raise your hand to save data, and automatically move into the next parameter setting.

✦ Set up insufficient-temperature alarm value  led display as shown in right figure: "P6" is the insufficient-temperature alarm value. The alarm will be given if the temperature droppes to this value. If any change is needed, please Press   until it displays the value you required. And press  and then raise your hand to save data, and automatically move into the next parameter setting.

✦ Set up over-humidity alarm: led display as

*	*	*
---	---	---

P	7
---	---

shown in right figure: "P7" is the over-humidity alarm value. The alarm will be given if the humidity reaches this value. If any change is needed, please press

▲

▼

 untill it displays the value you required. And press

OK

 and then raise your hand to save data, and automatically move into the next parameter setting.

✦ Set up upper limit value of humidity control

*	*	*
---	---	---

P	8
---	---

led display as shown in right figure: "P8" is the upper limit value of humidity control. The humidification will stop when the humidity reaches this value. If any change is needed, please press

▲

▼

 untill it displays the value you required. And press

OK

 and then raise your hand to save data, and automatically move into the next parameter setting.

✦ Set up lower limit value of humidity control:

*	*	*
---	---	---

P	9
---	---

led display as shown in right figure: "P9" is the lower limit of humidity control. The humidification will start when the humidity droppes to this value. If any change is needed, please press

▲

▼

 untill it displays the value you required. And press

OK

 and then raise your hand to save data, and automatically move into the next parameter setting.

✦ Set up low humidity alarm value: led

*	*	*
---	---	---

P	P
---	---

display as shown in right figure: "PP" is the low humidity alarm. The alarm will be given if the humidity droppes to this value. If any change is needed, please press

▲

▼

 untill it displays the value you required. And press

OK

 and then raise your hand to save data, and automatically move into the next parameter setting.

Set up Low humidity stop humidification: led

*	*	*
---	---	---

P	d
---	---

display as shown in right figure: "Pd" is the value of Low humidity stop humidification, When the humidity value is lower than this value, the humidification will stop. If any change is needed, please press

▲



▼

 untill it displays the value

OK

you required, and press **SET** and then raise your hand to return to the normal working state.

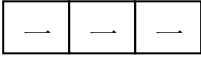
五、Egg-turning and calibration parameter setting

During normal operation, press the key **SET** and don't raise your hand, and then press the key  till display  





and then raise your hand, set up the following parameters:



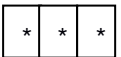

Set up egg-turning    





interval: as shown: "F1" is two successive egg-turning interval

(unit: minute), if any change is needed, please press  

Untill it displays the value you required. And press **OK** and then lift your hand to save data, and automatically move to the next parameter setting.

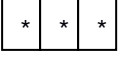
✧ Set up egg-turning time: led display as  
shown in right figure: "F2" is the egg-turning time (unit: second), which represents the time of turning eggs, if any change is necessary, please press   untill it displays the number you required. And press **OK** and then lift your hand to save data, and automatically move to the next parameter setting.

✧ Set up ventilation interval: led display as shown  
shown in right figure: "F3" is the ventilation interval time (unit: minute), if any change is needed, please press   untill it displays the value you required. And press **OK** and then raise your hand to save data, and automatically move into the next parameter setting.

✧ Set up ventilation time: led display as shown  
in right figure: "F4" is the ventilation time (unit: second), if any change is needed, please press   untill it displays the value you required. And press **OK** and then raise your hand to save data, and automatically move into the next parameter setting.

✧ Set up temperature calibration: led  

display as shown in right figure: "F5" is the temperature calibration value, this parameter may revise the temperature deviation brought about by improper selection of temperature measuring point. If any change is needed, please press ▲ ▼ until it displays the value you required. And press OK and then raise your hand to save data, and automatically move into the next parameter setting.

✦ Set up humidity calibration: led display as * * * F 6 shown in right figure: "F6" is the humidity calibration, this parameter may amend the humidity deviation caused by improper selection of humidity measuring point. If any change is needed, please press ▲ ▼ until it displays the value you required. And press OK and then raise your hand to save data, and automatically move into the next parameter setting.

✦✦ Number of egg-turning: led display as * * * F 7 shown in right figure: "F7" is the number of egg-turning, press the Key OK and then raise your hand to move into the next parameter setting.

✦✦ Number of brightness: led display as * * * F 8 shown in right figure: "F8" is the brightness of LED, If any change is needed, please press ▲ ▼ until it displays the value you required. And press OK and then raise your hand to save data, and automatically move into the next parameter setting.

✦ Time of Alarm Elimination: led display as * * * F 9 shown in right figure: "F9" is the Time of Alarm Elimination(unit: minute), If any change is needed, please press ▲ ▼ until it displays the value you required, and press OK and then raise your hand to return to the normal working state.

六、Egg-turning and Silencing Description

✦ Egg-turning:

Automatic egg-turning:



Turn eggs automatically in accordance with the set egg-turning

interval and egg-turing time, turn left → interval → turn right
→ interval → turn left... .. alternation of egg-turing. The number
of egg-turing will display on the parameter F7, and will be zero if
the controller power is cut off. In order to ensure normal
egg-turing, please switch to the state of automatic egg-turing.



Manual egg-turing:

Press the key  and do not lift your hand, the controller will
enter into the state of manual egg-turing after 2 seconds. You're
your hand when it is adjusted to the desired location, the controller
will get into the state of automatic egg-turing.

The computer will define automatically the direction of
egg-turing.

✦ **Silencing function:** when the controller give an alarm, press the
key  and lift your hand, to remove the buzzer sound and alarm
output, but then the alarm indicator lamp still lights up; press the
key  again and raise your hand, to restore buzzer sound and
alarm output control.

七、Restore Factory Settings

Press both keys of   at the same time for more than three
seconds, the controller will display zero. Raise hand immediately
after hearing "Di" from the buzzes the controller will automatically
restore the factory settings.

Factory Settings:

Reference temperature: 38.0°C; reference humidity: 60% RH;
cycle of egg-turing: 120-minute; time of egg-turing: 65
seconds; ventilation cycle: 120 minutes; ventilation time: 30
seconds; egg-turing state: automatic egg-turing

八、Controller Wiring Diagram:

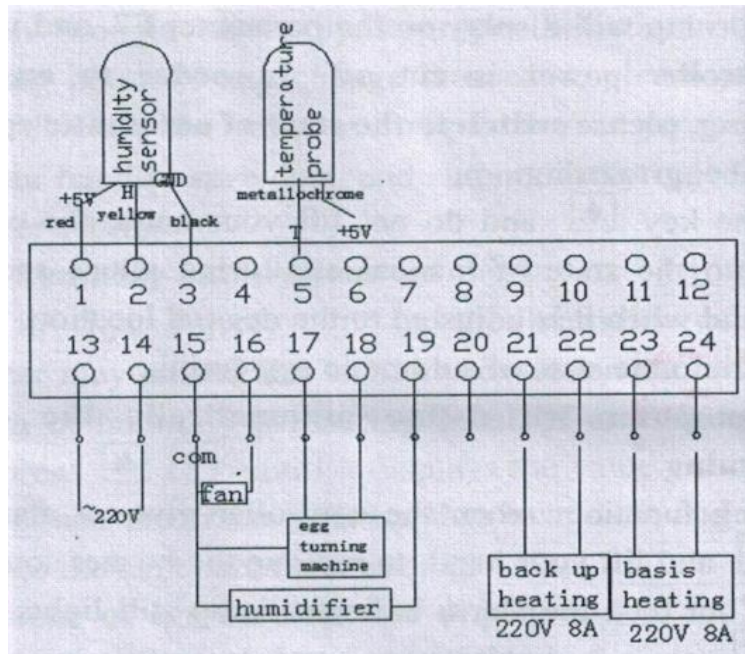

Dear Users:

Hello!

Welcome to use our automatic incubator by computer!

Please pay attention to the following aspects In use:

1. The micro-computer controller has been made adjustment for temperature, humidity, egg-turing, exhaust, etc. before leaving factory, which meets settings required by incubation. Under normal circumstances, you do not need to set up and may use it by connecting the power supply. Factory settings: temperature 38°C humidity 60% RH; cycle of egg-turning: 90-minute, time of egg-turning: 180 seconds; ventilation cycle: 120 minutes; ventilation time: 30 seconds; egg-turning state: automatic egg-turning.

2. If you need only to change the temperature and humidity parameters, please refer to Section III in page 2 of this Manual. Please do not set up other parameters in order to avoid operation errors which may affect your usage and bring you f unnecessary losses.

3. Temperature and humidity sensors are made of high precise and micro-molecular materials, please do not make the sensor come into contact with the water directly. The dust must be regularly cleared on the surface of the sensor; or it will affect the measurement

accuracy.

- 4. The manufacturer should only assume the obligation for products sold to users, but not undertake users' other losses caused by product failure.**