

HC 481 Hall Effect Switch IC

DESCRIPTION

The HC481 Hall-effect sensor is extremely temperature-stable and stress-resistant sensor ICs, especially suited for operation over extended temperature ranges from -40°C to 150°C . Superior high temperature performance is possible through dynamic offset cancellation, which reduces the residual offset voltage normally caused by device over-molding, temperature dependencies, and thermal stress.

The device includes a voltage regulator, Hall-voltage generator, small-signal amplifier, chopper stabilization, Schmitt trigger, and a short circuit protected open-drain output to sink up to 25 mA.

An on-board regulator permits operation with supply voltages of 2.8 to 26 V. The advantage of operating down to 2.8 V is that the device can be used in 2.8 V applications or with additional external resistance in series with the supply pin for greater protection against high-voltage transient events.

The HC481 can be programmed as a latch switch. Normally a south pole of sufficient strength turns on the output; However, the output polarity can be changed by programming EEPROM.

The falling time of driver can be programmed to reduce the EMI in automotive applications.

The HC481 also integrates internal clamps against supply transients; output short circuits protection; reverse battery conditions.

Three package styles provide a magnetically optimized package for most applications, SOT-23, SOT-89 and TO-92S. Each package type is lead (Pb) free (suffix, -T), with a 100% matte-tin-plated lead-frame.

FEATURES

- AEC-Q100 automotive qualified
- Customer-programmable operate point, Output polarity, Hysteresis (switch or latch), Output falling time for reduced EMI
- Factory-programmable TC of operate points
- Chopper stabilization for stable operate points throughout operating temperature range
- On board voltage regulator for 2.8V to 26V range
- Resistant to physical stress
- Output short-circuit protection
- Operation from unregulated supply
- Reverse-battery and freewheeling protection
- On-chip protection against Supply transients
- Wide Operating temperature range: -40 to 150 oC
- Small package sizes TO-92S, SOT-23 and SOT-89
- RoHS-compliant material meets directive 2011/65/EU

APPLICATIONS

- - Brushless dc (direct current) motor commutation
- - Motor and fan control
- - Robotics control
- - Speed and RPM sensing
- - Tachometer, counter pickup - Flow-rate sensing
- - Automobile gear shifter

FUNCTIONAL DIAGRAM

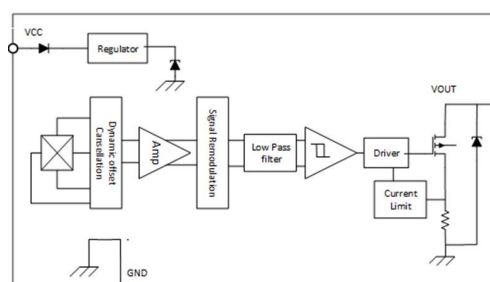

1. Product Family Members

Part Number	Marking ID	Description
HC481LX0SR_XXX_XXX_XX	C481	Bipolar latching, Hall-effect digital sensor IC, SOT-23-3L package, tape and reel packing (3000 units per reel)
HC481LX0TB_XXX_XXX_XX	C481	Bipolar latching, Hall-effect digital sensor IC, flat, TO-92S package, bulk packing (1000 units per bag)
HC481LX0ER_XXX_XXX_XX	C481	Bipolar latching, Hall-effect digital sensor IC, SOT-89-3L package, tape and reel packing (1000 units per reel)
HC481LX1SR_XXX_XXX_XX	C481	Bipolar latching, Hall-effect digital sensor IC, SOT-23-3L package, tape and reel packing (3000 units per reel)
HC481LX1TB_XXX_XXX_XX	C481	Bipolar latching, Hall-effect digital sensor IC, flat, TO-92S package, bulk packing (1000 units per bag)
HC481LX1ER_XXX_XXX_XX	C481	Bipolar latching, Hall-effect digital sensor IC, SOT-89-3L package, tape and reel packing (1000 units per reel)
HC481U00SR_XXX_XXX_XX	C481	Unipolar, Hall-effect digital sensor IC, SOT-23-3L package, tape and reel packing (3000 units per reel)
HC481U00TB_XXX_XXX_XX	C481	Unipolar, Hall-effect digital sensor IC, flat, TO-92S package, bulk packing (1000 units per bag)
HC481U01ER_XXX_XXX_XX	C481	Unipolar, Hall-effect digital sensor IC, SOT-89-3L package, tape and reel packing (1000 units per reel)
HC481U01SR_XXX_XXX_XX	C481	Unipolar, Hall-effect digital sensor IC, SOT-23-3L package, tape and reel packing (3000 units per reel)
HC481U01TB_XXX_XXX_XX	C481	Unipolar, Hall-effect digital sensor IC, flat, TO-92S package, bulk packing (1000 units per bag)
HC481U01ER_XXX_XXX_XX	C481	Unipolar, Hall-effect digital sensor IC, SOT-89-3L package, tape and reel packing (1000 units per reel)
HC481U10SR_XXX_XXX_XX	C481	Unipolar, Hall-effect digital sensor IC, SOT-23-3L package, tape and reel packing (3000 units per reel)
HC481U10TB_XXX_XXX_XX	C481	Unipolar, Hall-effect digital sensor IC, flat, TO-92S package, bulk packing (1000 units per bag)
HC481U10ER_XXX_XXX_XX	C481	Unipolar, Hall-effect digital sensor IC, SOT-89-3L package, tape and reel packing (1000 units per reel)
HC481U11SR_XXX_XXX_XX	C481	Unipolar, Hall-effect digital sensor IC, SOT-23-3L package, tape and reel packing (3000 units per reel)
HC481U11TB_XXX_XXX_XX	C481	Unipolar, Hall-effect digital sensor IC, flat, TO-92S package, bulk packing (1000 units per bag)
HC481U11ER_XXX_XXX_XX	C481	Unipolar, Hall-effect digital sensor IC, SOT-89-3L package, tape and reel packing (1000 units per reel)

2. Pin Definitions and Descriptions

SOT-23-3L (S)	TO-92S (T)	SOT-89-3L (E)	Name	Type	Function
1	1	1	VDD	Supply	Supply Voltage pin
2	3	3	OUT	Output	Open Drain Output pin
3	2	2	GND	Ground	Ground pin

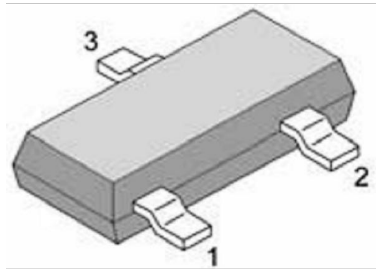

SOT-23-3L

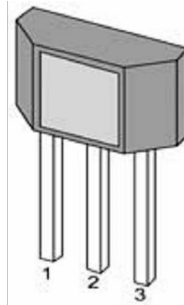

TO-92S

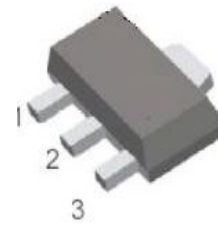

SOT-89-3L

3. Absolute Maximum Ratings

Parameter	Symbol	Min	Max	Units
Supply Voltage	V _{DD}	-	28	V
VDD Reverse Voltage VDD	V _{RDD}	-24		V
Supply Current	I _{DD}	-	20	mA
Output off Voltage	V _{OUT}	-0.3	28	V
Output Current	I _{OUT}	-	25	mA
Operating Ambient Temperature	T _A	-40	150	°C
Storage Temperature	T _S	-50	150	°C
Junction temperature	T _J	-50	165	°C
Magnetic Flux	B	No Limit		Gauss

Note: Exceeding the absolute maximum ratings may cause permanent damage. Exposure to absolutemaximum- rated conditions for extended periods may affect device reliability.

4. ESD Protections

Parameter	Value	Unit
All pins ¹⁾	+/-8000	V
All pins ²⁾	+/-200	V
All pins ³⁾	+/-750	V

- 1) HBM (Human Body Mode) according to AEC-Q100-002
- 2) MM (Machine Mode) according to AEC-Q100-003
- 3) CDM (charged device mode) according to AEC-Q100-011

5. Function Description

The HC481 exhibits programmable latch/Unipolar magnetic switching characteristics. Therefore, it requires both south and north poles or signal magnetic polar to operate properly.

The Latch mode behaves as a latch with symmetric operating and release switching points (BOP=|BRP|). This means magnetic fields with equivalent strength and opposite direction drive the output high and low.

Removing the magnetic field (B→0), it keeps the output in its previous state. This latching property defines the device as a magnetic memory.

A magnetic hysteresis BHYST keeps BOP and BRP separated by a minimal value. This hysteresis prevents output oscillation near the switching point.

The unipolar mode behaves as a unipolar with asymmetric operating and release switching points. This means While the magnetic flux density (B) is larger than operate point (Bop), the output will be turned on (Low), while the magnetic flux density(B) is lower than release point (Brp), then turn off (High) or depend the program bit, the output characteristic can be reverse.

6. Magnetic Activation

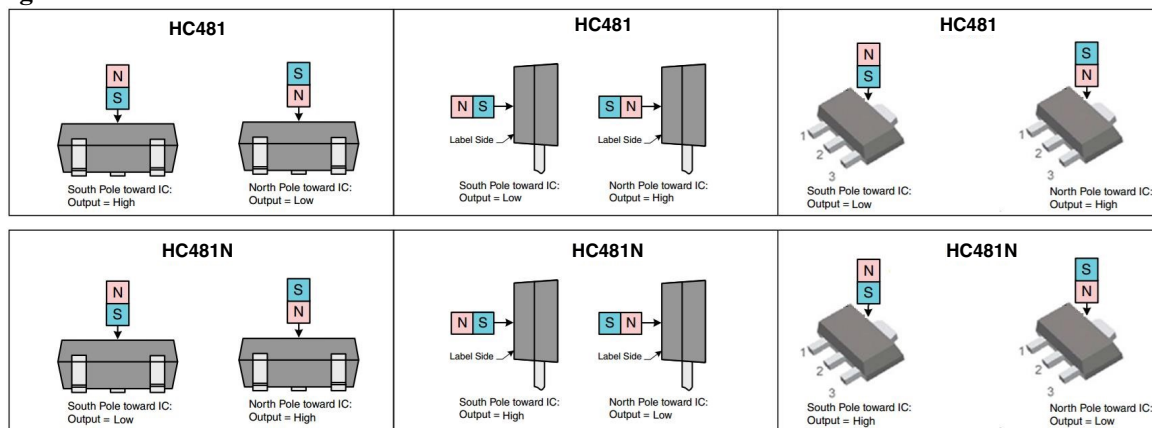

HC481N

7. Temperature Characteristics

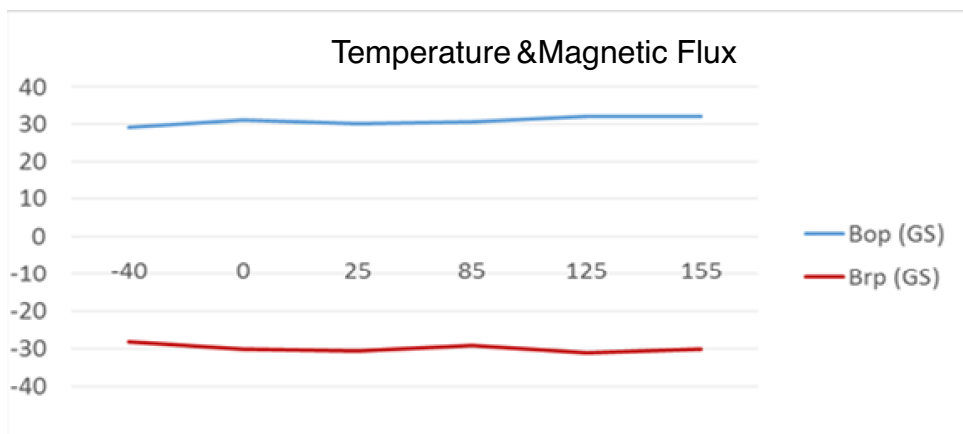

8. Parameters Specification (VCC=3.3V supply, TA= -40 °C to 150 °C except where otherwise specified.)

Symbol	Characteristic	Test Conditions	Min.	Typ.	Max.	Unit
VCC	Supply Voltage	Operating, T _J < 165°C	2.8		26	V
I _{CC}	Supply Current	No load on V _{OUT}	–	–	4	mA
V _{ZSUPPLY}	Supply Zener Clamp Voltage	I _{CC} = 7 mA; T _A = 25°C	28	–	–	V
V _{ZOUT}	Output Zener Clamp Voltage	I _{OUT} = 3mA	28.5	–	–	V
V _{RCC}	Reverse Battery Zener		-24	–		V
I _{RCC}	Reverse Battery Current	V _{CC} = -24 V	–	–	-5	mA
f _C	Chopping Frequency		–	500	–	kHz
t _{PO}	Power-On Time	T _A = 25°C; C _{LOAD} = 10 pF	–	–	30	μs
POS	Power-On State ²	POL = 0; B < B _{RP} , t > t _{po}	–	High	–	–
		POL = 1; B < B _{RP} , t > t _{po}	–	Low	–	–
V _{OUT(sat)}	Output Saturation Voltage	I _{OUT} = 20 mA	–	175	400	mV
I _{OFF}	Output Leakage Current	V _{OUT} = 26 V; Switch state = Off	–	–	10	μA
I _{OUT(lim)}	Output Current Limit	Short-Circuit Protection, Output = On	30	–	90	mA

t_r	Output Rise Time ^{3,4}	$V_{CC} = 12\text{ V}, R_{LOAD} = 820\ \Omega, C_{LOAD} = 10\ \text{pF}$	-	-	2	μs
		$V_{CC} = 12\text{ V}, R_{LOAD} = 2\ \text{k}\Omega, C_{LOAD} = 4.7\ \text{nF}$	-	21	-	μs
t_f	Output Fall Time ^{3,4}	$F_time = 00, V_{CC} = 12\text{ V}, R_{LOAD} = 820\ \Omega, C_{LOAD} = 10\ \text{pF}$	-	0.1	2	μs
		$F_time = 01, V_{CC} = 12\text{ V}, R_{LOAD} = 2\ \text{k}\Omega, C_{LOAD} = 4.7\ \text{nF}$	-	6.5	-	μs
		$F_time = 10, V_{CC} = 12\text{ V}, R_{LOAD} = 2\ \text{k}\Omega, C_{LOAD} = 4.7\ \text{nF}$	-	10	-	μs
		$F_time = 11, V_{CC} = 12\text{ V}, R_{LOAD} = 2\ \text{k}\Omega, C_{LOAD} = 4.7\ \text{nF}$	-	12.5	-	μs
POL	Output Polarity	POL=0, B>B _{OP}	-	Low	-	-
		POL=0, B<B _{RP}	-	High	-	-
		POL=1, B>B _{OP}	-	High	-	-
		POL=1, B<B _{RP}	-	Low	-	-
BOP_init	Pre-Programming BOP Target	TA = 25°C, BOPPOL = 0, mode=0	-	35	-	G
		TA = 25°C, BOPPOL = 1, mode=0	-	-35	-	G
Bhys_init	Pre-Programming Hysteresis	B _{OP} - B _{RP} , mode=0	10	15	20	G
BOP_init_L	Pre-Programming BOP Target	TA = 25°C, mode=1	-	35	-	G
BRP_init_L	Pre-Programming BRP Target	TA = 25°C, mode=1	-	-35	-	G
Bhys_init_L	Pre-Programming Hysteresis	B _{OP} - B _{RP} , mode=1	50	70	90	G
ΔBOP	Switch-point Thermal Drift ⁵	LT package, B _{OP} = $\pm 450\ \text{G}$	-0.14	-0.03	0.08	%/°C
		UA package, B _{OP} = $\pm 450\ \text{G}$	-0.08	0.00	0.08	%/°C
Bit _{BOPSEL}	BOP Magnitude Selection Bits		-	8	-	Bit
Res _{BOP}	BOP Step Size	Bit = LSB of BOPSEL	-	3	6	G
Bit _{BHYSSEL}	BHYS Magnitude Selection Bits		-	8	-	Bit
Res _{BHYS}	BHYS Step Size	Bit = LSB of BRPSEL	-	3	6	G
Bit _{BOPPOL}	Switchpoint Polarity Bits		-	1	-	Bit
Bit _{POL}	Output Polarity Bits		-	1	-	Bit
Bit _{FALL}	Fall Time Bits		-	2	-	Bit
Bit _{mode}	Modes Bits		-	1	-	Bit

B _{OP}	Programmable BOP Range	T _A = 25°C, BOPPOL = 1 (minimum at BOPSEL = 255, maximum at BOPSEL = 0), mode=0	-450	-	10	G
B _{OP}	Programmable BOP Range	T _A = 25°C, BOPPOL = 0 (minimum at BOPSEL = 0, maximum at BOPSEL = 255), mode=0	-10	-	450	G
B _{HYS}	Programmable BRP Range	T _A = 25°C, BOPPOL = 1 (minimum at BOPSEL = 255, maximum at BOPSEL = 0), mode=0	-450	-	15	G
B _{HYS}	Programmable BRP Range	T _A = 25°C, BOPPOL = 0 (minimum at BOPSEL = 0, maximum at BOPSEL = 255), mode=0	-15	-	450	G
B _{OP_L}	Programmable BOP Range	T _A = 25°C, BOPPOL = 0 (minimum at BOPSEL = 0, maximum at BOPSEL = 255), mode=1	7	-	450	G
B _{RP_L}	Programmable BRP Range	T _A = 25°C, BOPPOL = 1 (minimum at BOPSEL = 255, maximum at BOPSEL = 0), mode=1	-450	-	-7	G

- 1G (gauss) = 0.1 mT (millitesla).
 - Output state when device configured reference to the application diagram.
 - Output Rise Time is governed by external circuits tied to V_{OUT}.
 - Measured from 10% to 90% of the steady state output.
- Internal trimming utilized to minimize switch-point drift over the operating temperature range.

NOTICE

The magnetic field strength (Gauss) required to cause the switch to change state (operate and release) will be as specified in the magnetic characteristics. To test the switch against the specified magnetic characteristics, the switch must be placed in a uniform magnetic field.

9. Application Information

9.1 Typical Application

It is recommended that an external capacitor C_{bypass} is connected to the supply. This can reduce the noise injected into the device. Normal 0.1uF is suggested.

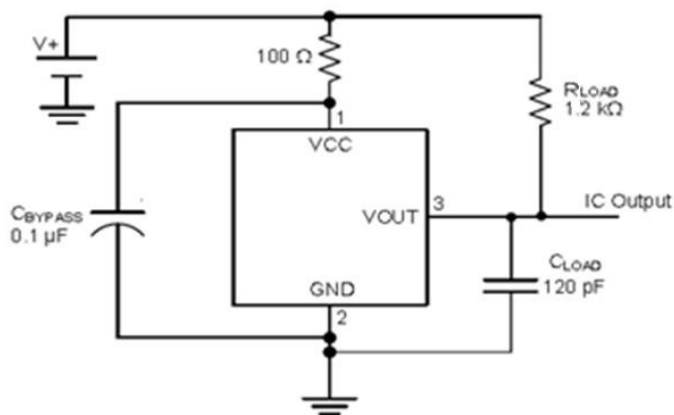

Typical Application Circuit

When mode=0, the Output Polarity bit is not set (POL = 0), the HC481 output switches on after the magnetic field at the Hall sensor IC exceeds the operate point threshold, BOP. When the magnetic field is reduced to below the release point threshold, BRP, the device output switches off. The difference

between the magnetic operate and release points is called the hysteresis of the device, BHYS. In the alternative case, in which the Output Polarity bit is set (POL = 1), HC481 response to magnetic pole is alternative; the HC481 output switches off when the magnetic field at the Hall sensor IC exceeds the operate point threshold, BRP. When the magnetic field is reduced to below the release point threshold, BOP, the device output switches on.

When mode=0, BOPPOL=1, the devices is configured as invert unipolar switch. The output of states depends on POL, if POL=0, the device turns off when field is lower than Bop, turns on when higher than Brp; If POL=1, the device turns off when field is lower than Brp, turns on when field lower than Bop.

Note that for the Pre-Programming BOP Target, BOPinit , when BOPPOL = 0 although the operating range is 0 to B+, the initial BOPinit is actually negative, and likewise, when BOPPOL = 1, although the operating range 0 to B- , the initial BOPinit is actually positive.

If the mode=1, the device is configured as latch, in this case, the Bop=-Brp, if the field is higher than Bop, the device is turned on. The device is turned off when the field is lower than Brp. At this case, BOPPOL is ineffective.

9.2 Device Output

If the device is powered on with a magnetic field strength between BRP and BOP, then the device output is indeterminate and can either be Hi-Z or Low. If the field strength is greater than BOP, then the output is pulled low. If the field strength is less than BRP, then the output is released.

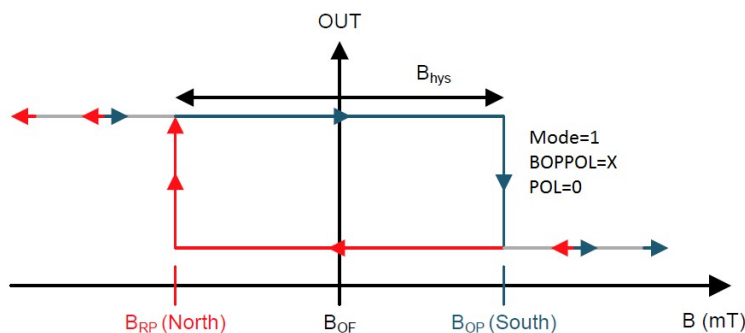

Latch: output voltage characteristic (Mode=1, BOPPOL=X, POL=0)

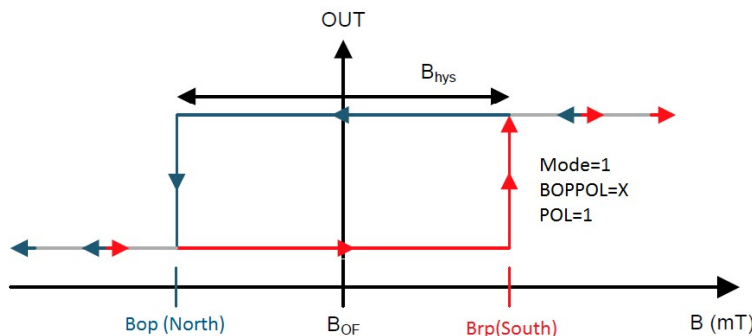

Latch: output voltage characteristic (Mode=1, BOPPOL=X, POL=1)

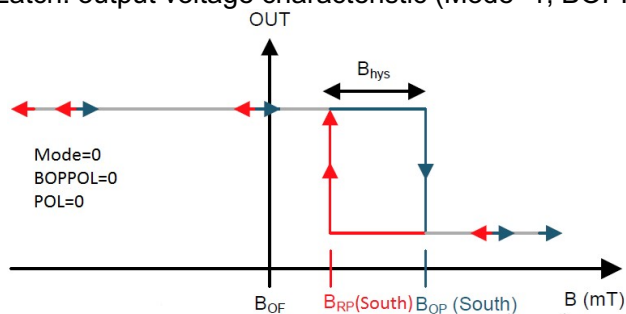

Unipolar: output voltage characteristic (Mode=0, BOPPOL=0, POL=0)

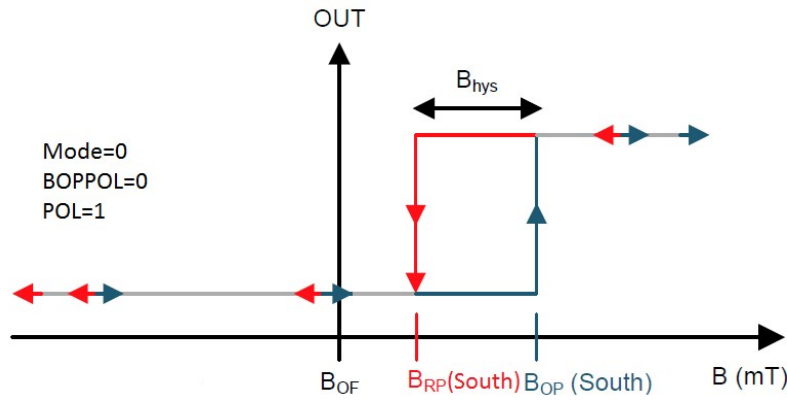

Unipolar: output voltage characteristic (Mode=0, BOPPOL=0, POL=1)

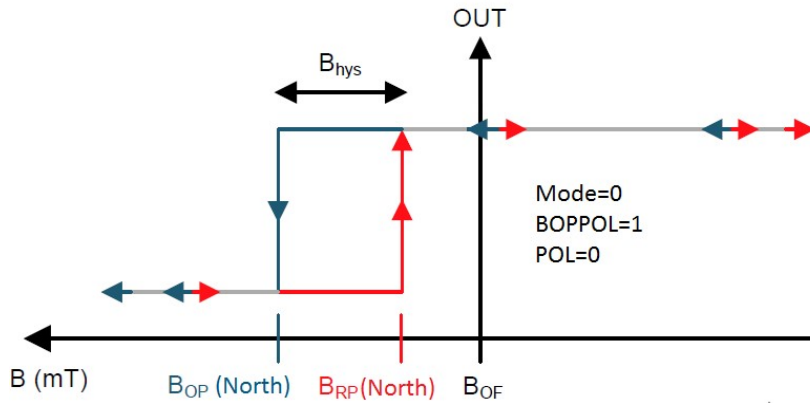

Unipolar: output voltage characteristic (Mode=0, BOPPOL=1, POL=0)

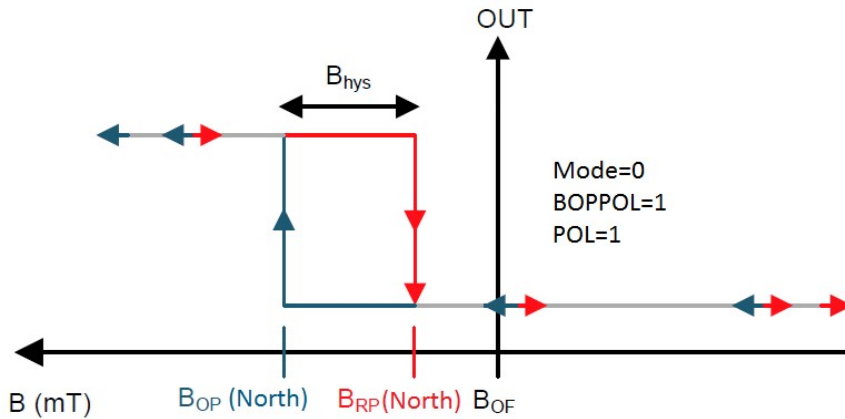

Unipolar: output voltage characteristic (Mode=0, BOPPOL=1, POL=1)

9.3 Output Stage

The HC481 output stage uses an open-drain NMOS, and it is rated to sink up to 30 mA of current. For proper operation, calculate the value of the pullup resistor R1 using Equation 1.

$$\frac{V_{ref\ max}}{30\ mA} \leq R1 \leq \frac{V_{ref\ min}}{100\ \mu A} \quad (1)$$

The size of R1 is a tradeoff between the OUT rise time and the current when OUT is pulled low. A lower current is generally better, however faster transitions and bandwidth require a smaller resistor for faster switching. In addition, ensure that the value of R1 > 500 Ω to ensure the output driver can pull the OUT pin close to GND.

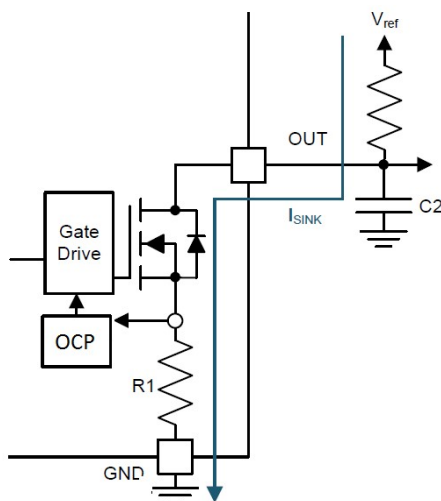

$$2 \times f_{BW} \text{ (Hz)} < \frac{1}{2\pi \times R1 \times C2} \quad (2)$$

Select a value for C2 based on the system bandwidth specifications shown in [Equation 2](#).

Most applications do not require this C2 filtering capacitor.

9.4 Protection Circuits

The HC481 device is fully protected against overcurrent and reverse-supply conditions.

9.5 Overcurrent Protection (OCP)

An analog current-limit circuit limits the current through the FET. The driver current is clamped to IOCP. During this clamping, the rDS(on) of the output FET is increased from the nominal value.

9.6 Reverse Supply Protection

The HC481 device is protected in the event that the VCC pin and the GND pin are reversed (up to -24 V).

9.7 Alternative Two-Wire Application

For systems that require minimal wire count, the device output can be connected to VCC through a resistor, and the total supplied current can be sensed near the controller.

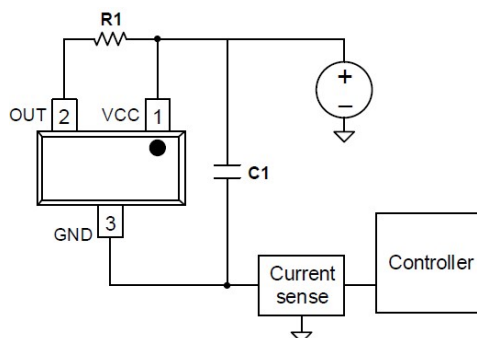

2-Wire Application

Current can be sensed using a shunt resistor or other circuitry.

11. Package Information:

PACKAGE DESIGNATOR TO-92S

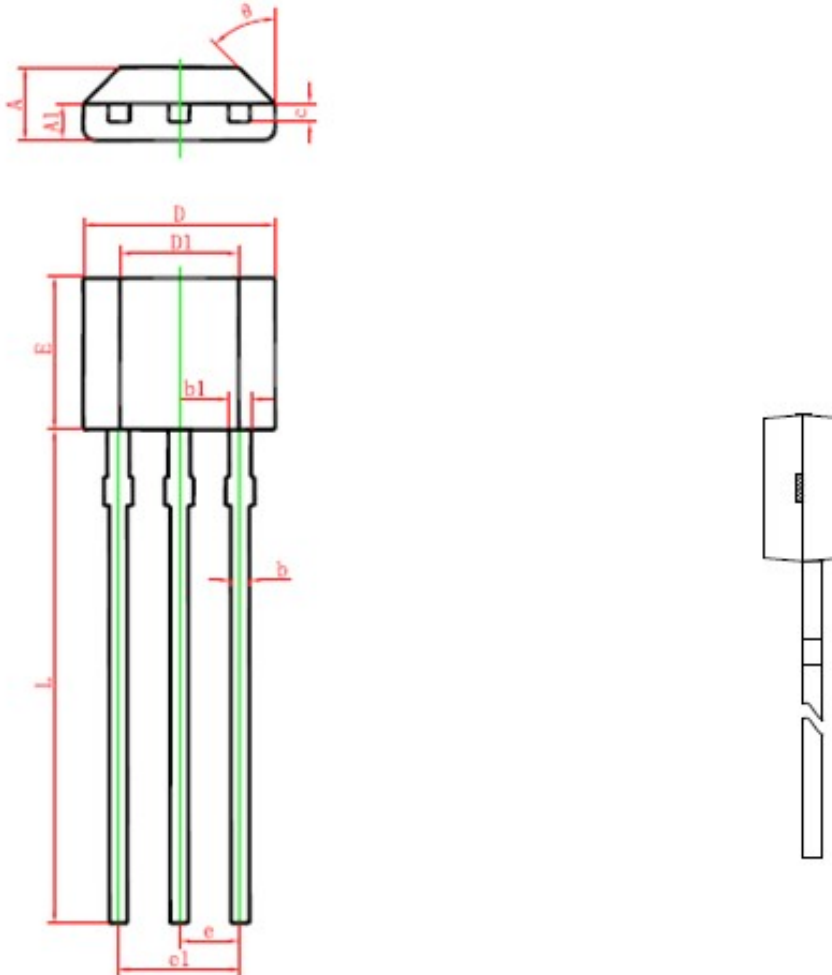

Symbol	Dimensions In Millimeters		Dimensions In Inches	
	Min.	Max.	Min.	Max.
A	1.420	1.620	0.056	0.064
A1	0.660	0.860	0.026	0.034
b	0.350	0.480	0.014	0.019
b1	0.400	0.550	0.016	0.022
c	0.360	0.510	0.014	0.020
D	3.900	4.100	0.154	0.161
D1	2.280	2.680	0.090	0.106
E	3.050	3.250	0.120	0.128
e	1.270 TYP.		0.050 TYP.	
e1	2.440	2.640	0.096	0.104
L	15.100	15.500	0.594	0.610
theta	45° TYP.		45° TYP.	

PACKAGE DESIGNATOR
SOT-23-3L

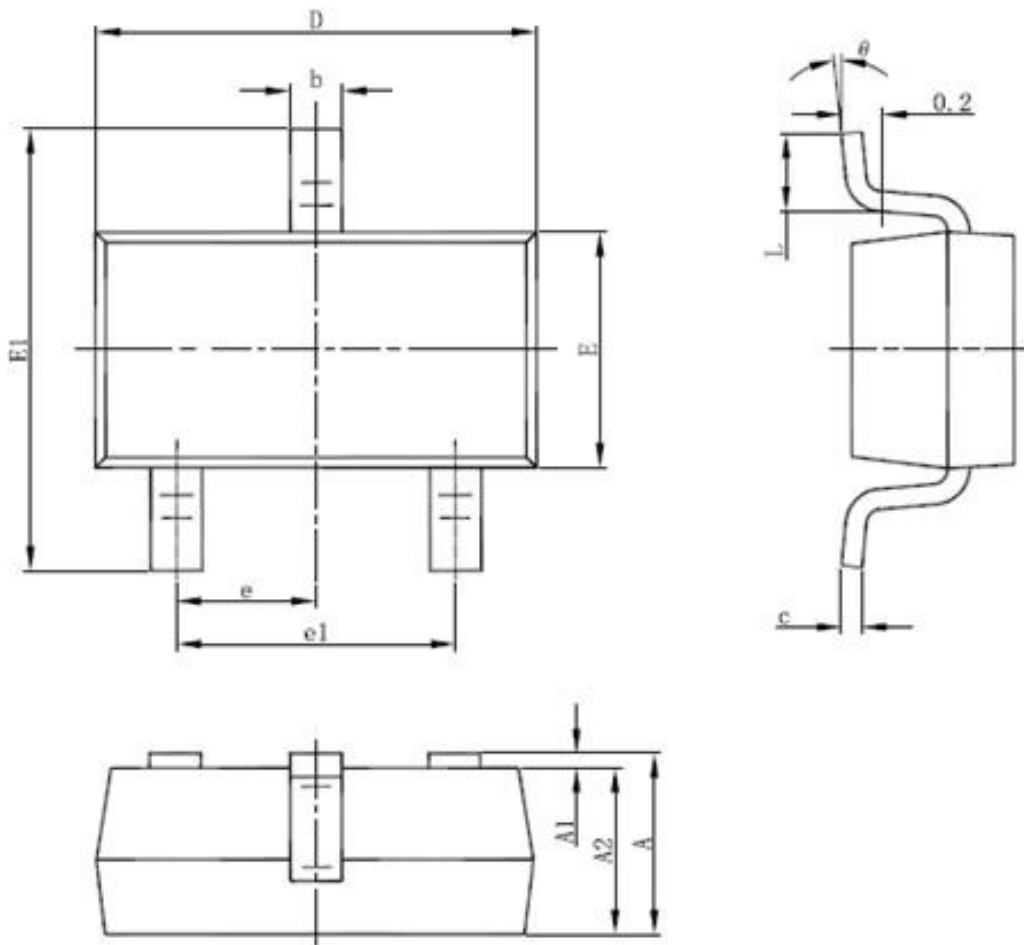

Symbol	Dimensions In Millimeters		Dimensions In Inches	
	Min	Max	Min	Max
A	1.050	1.250	0.041	0.049
A1	0.000	0.100	0.000	0.004
A2	1.050	1.150	0.041	0.045
b	0.300	0.500	0.012	0.020
c	0.100	0.200	0.004	0.008
D	2.820	3.020	0.111	0.119
E	1.500	1.700	0.059	0.067
E1	2.650	2.950	0.104	0.116
e	0.950(BSC)		0.037(BSC)	
e1	1.800	2.000	0.071	0.079
L	0.300	0.600	0.012	0.024
θ	0°	8°	0°	8°

PACKAGE DESIGNATOR
SOT-89-3L

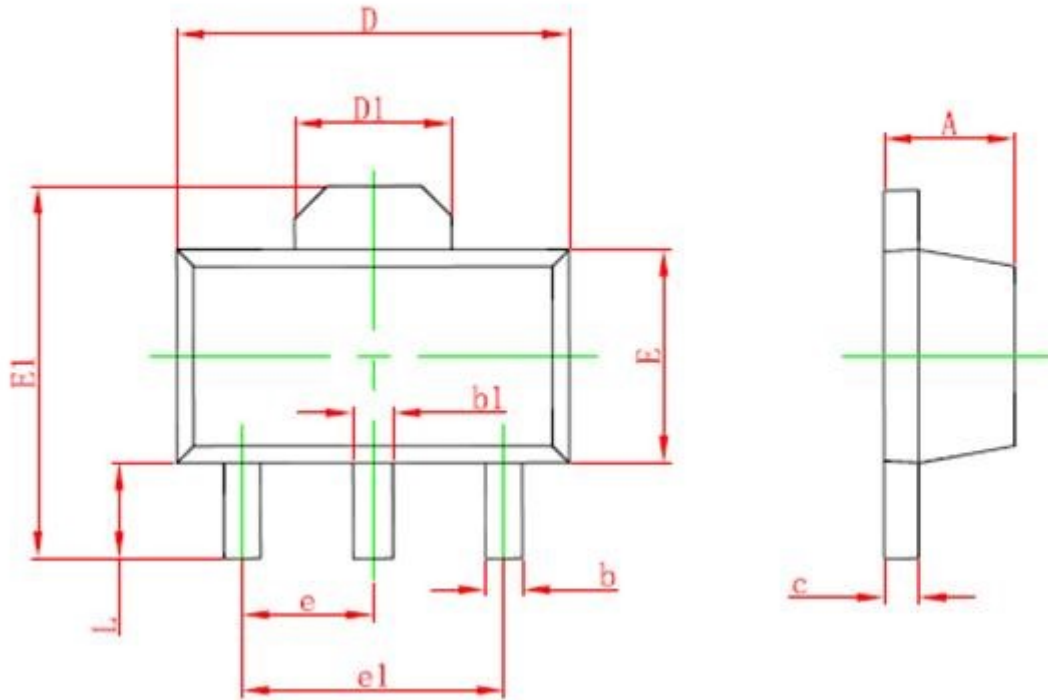

Symbol	Dimensions In Millimeters		Dimensions In Inches	
	Min.	Max.	Min.	Max.
A	1.400	1.600	0.055	0.063
b	0.320	0.520	0.013	0.020
b1	0.400	0.580	0.016	0.023
c	0.350	0.440	0.014	0.017
D	4.400	4.600	0.173	0.181
D1	1.550 REF.		0.061 REF.	
E	2.300	2.600	0.091	0.102
E1	3.940	4.250	0.155	0.167
e	1.500 TYP.		0.060 TYP.	
e1	3.000 TYP.		0.118 TYP.	
L	0.900	1.200	0.035	0.047