

HC701

AEC-Q100 Qualified, 3000V_{RMS} Isolation
Hall Current Sensor IC in SO8 Package

Features

- Reinforced isolation: **3000V_{RMS}**
- Total output error: **±1% typical**
- AEC-Q100 qualified
- Primary conductor resistance: **0.8 mΩ**
- Single supply: **3.3V or 5V**
- Output voltage proportional to AC or DC current: **±5A, ±10A, ±12.5A, ±20A, ±30A, ±40A, ±50A**
- Bandwidth: **120 kHz**
- Response time: **4 us**
- Ratio-metric output from supply voltage
- Adjustable bandwidth and resolution with a filter pin
- Small-footprint SOIC-8 package suitable for replacing bulky transformers or shunt current sensing solutions
- Integrated shield virtually eliminates capacitive coupling from current conductor to die, greatly suppressing output noise due to high dv/dt transients
- Factory-trimmed sensitivity and quiescent output voltage for improved accuracy
- Chopper stabilization results in extremely stable quiescent output voltage

Package



SO-8

Application

- Variable-frequency inverters
- Motor control
- Over-current fault protection
- Load detection and management

Functional Block Diagram

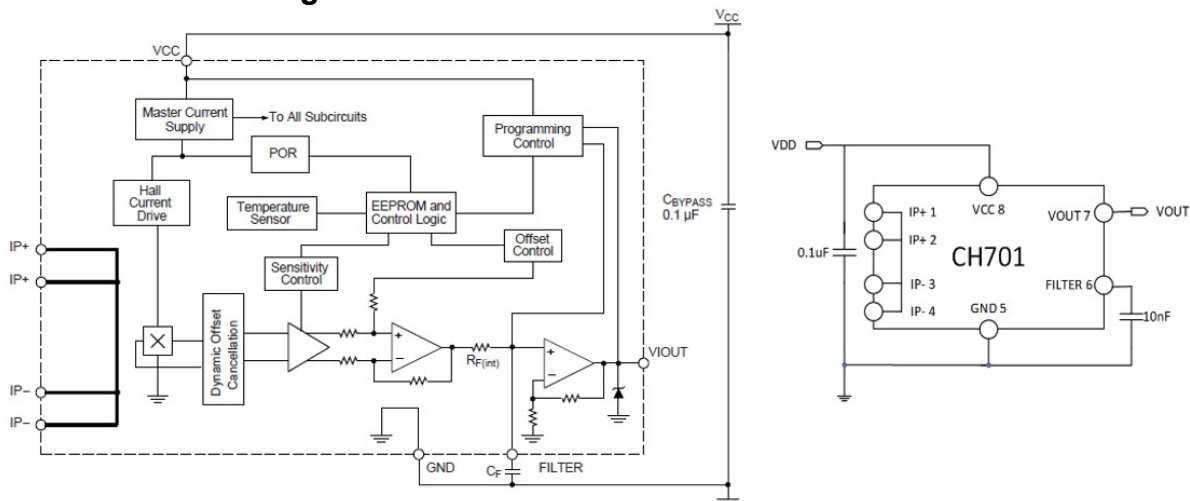

Description

The HC701 current sensor IC is an economical and precise solution for AC or DC current sensing in industrial, automotive, commercial, and communications systems. The small package is ideal for space-constrained applications while also saving costs due to reduced board area. Typical applications include motor control, load detection and management, switched-mode power supplies, and overcurrent fault protection.

The device consists of a precise, low-offset, linear Hall sensor circuit with a copper conduction path located near the surface of the die. Applied current flowing through this copper conduction path generates a magnetic field which is sensed by the integrated Hall IC and converted into a proportional

voltage. A precise, proportional voltage is provided by the low-offset, chopper-stabilized BCD Hall IC, which is programmed for accuracy after packaging. The output of the device has a positive slope when an increasing current flows through the primary copper conduction path (from pins 1 and 2, to pins 3 and 4), which is the path used for current sensing. The internal resistance of this conductive path is 0.8 m Ω typical, providing low power loss.

The terminals of the conductive path are electrically isolated from the sensor leads (pins 5 through 8). This allows the HC701 current sensor IC to be used in high-side current sense applications without the use of high-side differential amplifiers or other costly isolation techniques.

The HC701 is provided in a small, low-profile surface-mount SOIC8 package. The leadframe is plated with 100% matte tin, which is compatible with standard lead (Pb) free printed circuit board assembly processes. Internally, the device is Pb-free, except for flip-chip high-temperature Pb-based solder balls, currently exempt from RoHS. The device is fully calibrated prior to shipment from the factory.

Table of Contents

1 PRODUCT FAMILY MEMBERS	4
2 PIN DEFINITIONS AND DESCRIPTIONS	5
3 ABSOLUTE MAXIMUM RATINGS	6
4 ESD PROTECTIONS	6
5 ELECTRICAL CHARACTERISTICS:	7
6 APPLICATION INFORMATION	67
7 PACKAGE INFORMATION:	70

1 Product Family Members

HC701x is available in a variety of delivery forms. They are distinguished by a specific nomenclature code:

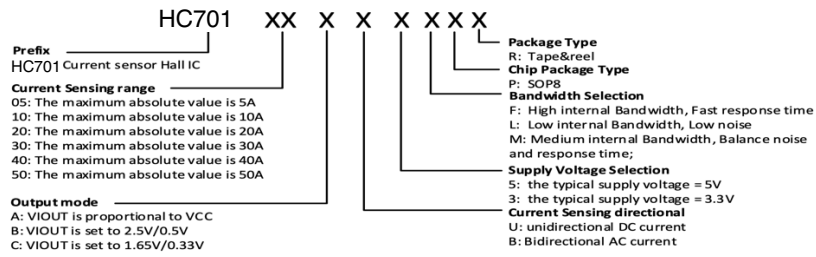

Part Number	VCC (V)	I _{PR} (A)	Sens (mV/A)	T _j (°C)	Packing
HC70105AU5*	5±0.5	5	800	-40 to 150	Tape and Reel, 3000 pieces per reel
HC70105AU3*	3.3±0.3	5	528		
HC70105AB5*	5±0.5	±5	400		
HC70105AB3*	3.3±0.3	±5	264		
HC70105BU5*	5±0.5	5	800		
HC70105BB5*	5±0.5	±5	400		
HC70105CU3*	3.3±0.3	5	528		
HC70105CB3*	3.3±0.3	±5	264		
HC70110AU5*	5±0.5	10	400		
HC70110AU3*	3.3±0.3	10	264		
HC70110AB5*	5±0.5	±10	200		
HC70110AB3*	3.3±0.3	±10	132		
HC70110BU5*	5±0.5	10	400		
HC70110BB5*	5±0.5	±10	200		
HC70110CU3*	3.3±0.3	10	264		
HC70110CB3*	3.3±0.3	±10	132		
HC70112AB5*	5±0.5	±12.5	110		
HC70112AB3*	3.3±0.3	±12.5	110		
HC70120AU5*	5±0.5	20	200		
HC70120AU3*	3.3±0.3	20	132		
HC70120AB5*	5±0.5	±20	100		
HC70120AB3*	3.3±0.3	±20	66		
HC70120BU5*	5±0.5	20	200		
HC70120BB5*	5±0.5	±20	100		
HC70120CU3*	3.3±0.3	20	132		
HC70120CB3*	3.3±0.3	±20	66		
HC70130AU5*	5±0.5	30	133		
HC70130AU3*	3.3±0.3	30	88		
HC70130AB5*	5±0.5	±30	66		
HC70130AB3*	3.3±0.3	±30	44		
HC70130BU5*	5±0.5	30	133		
HC70130BB5*	5±0.5	±30	66		
HC70130CU3*	3.3±0.3	30	88		
HC70130CB3*	3.3±0.3	±30	44		
HC70140AU5*	5±0.5	40	100		
HC70140AU3*	3.3±0.3	40	66		
HC70140AB5*	5±0.5	±40	50		
HC70140AB3*	3.3±0.3	±40	33		
HC70140BU5*	5±0.5	40	100		
HC70140BB5*	5±0.5	±40	50		
HC70140CU3*	3.3±0.3	40	66		
HC70140CB3*	3.3±0.3	±40	33		
HC70150AU5*	5±0.5	50	80		
HC70150AU3*	3.3±0.3	50	52		
HC70150AB5*	5±0.5	±50	40		
HC70150AB3*	3.3±0.3	±50	26		
HC70150BU5*	5±0.5	50	80		
HC70150BB5*	5±0.5	±50	40		
HC70150CU3*	3.3±0.3	50	52		
HC70150CB3*	3.3±0.3	±50	26		

2 Pin Definitions and Descriptions

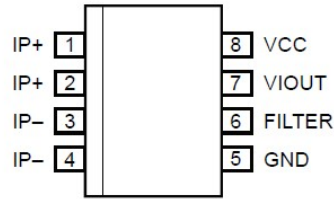

**Package LC, 8-Pin SOICN
Pin-Out Diagram**

Number	Name	Function
1,2	IP+	Terminals for current being sensed, fused internally
3,4	IP-	Terminals for current being sensed, fused internally
5	GND	Signal ground terminal
6	FILTER	Terminal for external capacitor that sets bandwidth
7	VIOUT	Analog output signal
8	VCC	Device power supply terminal

3 Absolute Maximum Ratings

Parameter	Symbol	Min	Max	Units
Supply Voltage	V_{CC}	-	6	V
Reverse Supply Voltage	V_{RCC}	-0.1	-	V
Output Voltage	V_{IOUT}	-	$V_{CC} + 0.5$	V
Reverse Output Voltage	V_{RIOUT}	-0.1	-	V
Operating Ambient Temperature	T_A	-40	150	°C
Storage Temperature	T_S	-65	165	°C
Junction temperature	$T_{J(max)}$		165	°C

Note 1: Exceeding the absolute maximum ratings may cause permanent damage. Exposure to absolute-maximum-rated conditions for extended periods may affect device reliability.

Isolation Characteristics

Characteristic	Symbol	Notes	Rating	Unit
Dielectric Strength Test Voltage	V_{ISO}	Agency type-tested for 60 seconds per UL 62368-1 (edition 3); production-tested at V_{ISO} for 1 second, in accordance with UL 62368-1 (edition 3). UL62368-1 (edition 3) replaces UL60950-1.	3000	V_{RMS}
Working Voltage for Basic Isolation	V_{WVBI}	Maximum approved working voltage for basic (single) isolation according to UL 62368-1 (edition 3). UL62368-1 (edition 3) replaces UL60950-1.	725	V_{pk} or VDC
			513	V_{rms}

Thermal Characteristics

Characteristic	Symbol	Test Conditions*	Value	Units
Package Thermal Resistance (Junction to Ambient)	$R_{\theta JA}$		23	°C/W
Package Thermal Resistance (Junction to Lead)	$R_{\theta JL}$		5	°C/W

4 ESD Protections

Parameter	Value	Unit
All pins ¹⁾	±8000	V
All pins ²⁾	±400	V
All pins ³⁾	±1500	V

1) HBM (human body mode, 100pF, 1.5 kΩ) according to MIL-STD-883H Method 3015.8

2) MM (Machine Mode C=200pF, R=0Ω) according to JEDEC EIA/JESD22-A115

3) CDM (charged device mode) according to JEDEC EIA/JESD22-C101F

5 Electrical Characteristics:

Valid through the full range of T_A , $V_{CC} = 5\text{ V}$, $C_F = 0$, unless otherwise specified

Characteristic ¹	Symbol	Test Conditions	Min.	Typ.	Max.	Unit
Supply Current	I_{CC}	$V_{CC} = 5\text{ V}$, output open	–	10	14	mA
Output Capacitance Load	C_L	VIOOUT to GND	–	–	10	nF
Output Resistive Load	R_L	VIOOUT to GND	4.7	–	–	k Ω
Primary Conductor Resistance	R_{IP}	$T_A = 25^\circ\text{C}$	–	0.8	–	m Ω
Internal Filter Resistance ²	$R_{F(int)}$		–	1.7	–	k Ω
Rise Time	t_r	$I_P = I_{P(max)}$, $T_A = 25^\circ\text{C}$, $C_L = 1\text{ nF}$	–	3	–	μs
Propagation Delay	t_{pd}	$I_P = I_{P(max)}$, $T_A = 25^\circ\text{C}$, $C_L = 1\text{ nF}$	–	2	–	μs
Response Time	$t_{RESPONSE}$	$I_P = I_{P(max)}$, $T_A = 25^\circ\text{C}$, $C_L = 1\text{ nF}$	–	4	–	μs
Bandwidth	BW	Small signal –3 dB; $C_L = 1\text{ nF}$	–	120	–	kHz
Noise Density	I_{ND}	Input-referenced noise density; $T_A = 25^\circ\text{C}$, $C_L = 1\text{ nF}$	–	150	–	$\mu\text{A}_{(rms)}/\sqrt{\text{Hz}}$
Noise	I_N	Input-referenced noise: $C_F = 4.7\text{ nF}$, $C_L = 1\text{ nF}$, BW = 18 kHz, $T_A = 25^\circ\text{C}$	–	25	–	$\text{mA}_{(rms)}$
Nonlinearity	ELIN	Through full range of I_P		± 1		%
Sensitivity Ratiometry Coefficient	SENS_RAT_COEF	$V_{CC} = 4.5\text{ to }5.5\text{ V}$, $T_A = 25^\circ\text{C}$	–	1.3	–	–
Zero-Current Output Ratiometry Coefficient	QVO_RAT_COEF	$V_{CC} = 4.5\text{ to }5.5\text{ V}$, $T_A = 25^\circ\text{C}$	–	1	–	–
Saturation Voltage ³	V_{OH}	$R_L = 4.7\text{ k}\Omega$, $T_A = 25^\circ\text{C}$	$V_{CC} - 0.2$		–	V
	V_{OL}	$R_L = 4.7\text{ k}\Omega$, $T_A = 25^\circ\text{C}$	–		0.2	V
Power-On Time	t_{PO}	Output reaches 90% of steadystate level, $T_A = 25^\circ\text{C}$, $I_P = I_{PR(max)}$ applied	–	62	–	μs
Shorted Output-to-Ground Current	$I_{SC(GND)}$	$T_A = 25^\circ\text{C}$	–	3.3	–	mA
Shorted Output-to- V_{CC} Current	$I_{SC(VCC)}$	$T_A = 25^\circ\text{C}$	–	45	–	mA

¹ Device may be operated at higher primary current levels, I_P , ambient temperatures, T_A , and internal leadframe temperatures, provided the Maximum Junction Temperature, $T_J(max)$, is not exceeded.

² $R_{F(int)}$ forms an RC circuit via the FILTER pin.

³ The sensor IC will continue to respond to current beyond the range of I_P until the high or low saturation voltage; however, the nonlinearity in this region will be worse than through the rest of the measurement range.

HC70105AU3

unless otherwise specified

Characteristic	Symbol	Test Conditions	Min.	Typ. ¹	Max.	Unit
Nominal Performance						
Supply Voltage	V _{CC}		3	–	3.6	V
Current-Sensing Range	I _{PR}		0	–	5	A
Sensitivity	Sens	$ I_{PR(min)} < I < I_{PR(max)} $, VCC = 3.3V	–	480	–	mV/A
Zero-Current Output Voltage	V _{IOUT(Q)}	Unidirectional, I _P = 0 A, VCC = 3.3V	–	0.45	–	V
Accuracy Performance						
Total Output Error ²	E _{TOT}	I _P = I _{PR(max)} , T _j = -40°C to 150°C	-2.5	±1.5	2.5	%
Total Output Error Components³ E_{TOT} = E_{SENS} + 100 × V_{OE}/(Sens × I_P)						
Sensitivity Error	E _{sens}	I _P = I _{PR(max)} , T _j = -40°C to 150°C	-2	±1	2	%
Offset Voltage	V _{OE}	I _P = 0 A, T _j = -40°C to 150°C	-15	±7	15	mV
Lifetime Drift Characteristics						
Sensitivity Error Lifetime Drift	E _{sens_drift}			±1		%
Total Output Error Lifetime Drift	E _{tot_drift}			±1		%

¹ Typical values with +/- are 3 sigma values

² Percentage of I_P, with I_P = I_{PR(max)}.

³ A single part will not have both the maximum/minimum sensitivity error and maximum/minimum offset voltage, as that would violate the maximum/minimum total output error specification. Also, 3 sigma distribution values are combined by taking the square root of the sum of the squares. See Application Information section.

HC70105AB5

unless otherwise specified

Characteristic	Symbol	Test Conditions	Min.	Typ. ¹	Max.	Unit
Nominal Performance						
Supply Voltage	V_{CC}		4.5	–	5.5	V
Current-Sensing Range	I_{PR}		-5	–	5	A
Sensitivity	Sens	$ I_{PR(min)} < I < I_{PR(max)} $, $V_{CC} = 5V$	–	400	–	mV/A
Zero-Current Output Voltage	$V_{IOUT(Q)}$	Bidirectional, $I_P = 0 A$, $V_{CC} = 5V$	–	$V_{CC} \times 0.5$	–	V
Accuracy Performance						
Total Output Error ²	E_{TOT}	$I_P = I_{PR(max)}$, $T_j = -40^\circ C$ to $150^\circ C$	-2	± 1	2	%
Total Output Error Components³ $E_{TOT} = E_{SENS} + 100 \times V_{OE} / (Sens \times I_P)$						
Sensitivity Error	E_{sens}	$I_P = I_{PR(max)}$, $T_j = -40^\circ C$ to $150^\circ C$	-1.5	± 1	1.5	%
Offset Voltage	V_{OE}	$I_P = 0 A$, $T_j = -40^\circ C$ to $150^\circ C$	-10	± 6	10	mV
Lifetime Drift Characteristics						
Sensitivity Error Lifetime Drift	E_{sens_drift}			± 1		%
Total Output Error Lifetime Drift	E_{tot_drift}			± 1		%

¹ Typical values with +/- are 3 sigma values

² Percentage of I_P , with $I_P = I_{PR(max)}$.

³ A single part will not have both the maximum/minimum sensitivity error and maximum/minimum offset voltage, as that would violate the maximum/minimum total output error specification. Also, 3 sigma distribution values are combined by taking the square root of the sum of the squares. See Application Information section.

HC70105AB3

unless otherwise specified

Characteristic	Symbol	Test Conditions	Min.	Typ. ¹	Max.	Unit
Nominal Performance						
Supply Voltage	V_{CC}		3	–	3.6	V
Current-Sensing Range	I_{PR}		-5	–	5	A
Sensitivity	Sens	$ I_{PR(min)} < I < I_{PR(max)} $, $V_{CC} = 3.3V$	–	264	–	mV/A
Zero-Current Output Voltage	$V_{IOUT(Q)}$	Bidirectional, $I_P = 0 A$, $V_{CC} = 3.3V$	–	$V_{CC} \times 0.5$	–	V
Accuracy Performance						
Total Output Error ²	E_{TOT}	$I_P = I_{PR(max)}$, $T_j = -40^\circ C$ to $150^\circ C$	-2	± 1	2	%
Total Output Error Components³ $E_{TOT} = E_{SENS} + 100 \times V_{OE} / (Sens \times I_P)$						
Sensitivity Error	E_{sens}	$I_P = I_{PR(max)}$, $T_j = -40^\circ C$ to $150^\circ C$	-1.5	± 1	1.5	%
Offset Voltage	V_{OE}	$I_P = 0 A$, $T_j = -40^\circ C$ to $150^\circ C$	-10	± 6	10	mV
Lifetime Drift Characteristics						
Sensitivity Error Lifetime Drift	E_{sens_drift}			± 1		%
Total Output Error Lifetime Drift	E_{tot_drift}			± 1		%

¹ Typical values with +/- are 3 sigma values

² Percentage of I_P , with $I_P = I_{PR(max)}$.

³ A single part will not have both the maximum/minimum sensitivity error and maximum/minimum offset voltage, as that would violate the maximum/minimum total output error specification. Also, 3 sigma distribution values are combined by taking the square root of the sum of the squares. See Application Information section.

HC70105BU5

unless otherwise specified

Characteristic	Symbol	Test Conditions	Min.	Typ. ¹	Max.	Unit
Nominal Performance						
Supply Voltage	V _{CC}		4.5	–	5.5	V
Current-Sensing Range	I _{PR}		0	–	5	A
Sensitivity	Sens	$I_{PR(min)} < I_P < I_{PR(max)}$	–	740	–	mV/A
Zero-Current Output Voltage	V _{IOUT(Q)}	Unidirectional, I _P = 0 A	–	0.65	–	V
Accuracy Performance						
Total Output Error ²	E _{TOT}	I _P = I _{PR(max)} , T _j = -40°C to 150°C	-2.5	±1.5	2.5	%
Total Output Error Components³ E_{TOT} = E_{SENS} + 100 × V_{OE} / (Sens × I_P)						
Sensitivity Error	E _{sens}	I _P = I _{PR(max)} , T _j = -40°C to 150°C	-2	±1	2	%
Offset Voltage	V _{OE}	I _P = 0 A, T _j = -40°C to 150°C	-15	±7	15	mV
Lifetime Drift Characteristics						
Sensitivity Error Lifetime Drift	E _{sens_drift}			±1		%
Total Output Error Lifetime Drift	E _{tot_drift}			±1		%

¹ Typical values with +/- are 3 sigma values

² Percentage of I_P, with I_P = I_{PR(max)}.

³ A single part will not have both the maximum/minimum sensitivity error and maximum/minimum offset voltage, as that would violate the maximum/minimum total output error specification. Also, 3 sigma distribution values are combined by taking the square root of the sum of the squares. See Application Information section.

HC70105BB5

unless otherwise specified

Characteristic	Symbol	Test Conditions	Min.	Typ. ¹	Max.	Unit
Nominal Performance						
Supply Voltage	V_{CC}		4.5	–	5.5	V
Current-Sensing Range	I_{PR}		-5	–	5	A
Sensitivity	Sens	$I_{PR(min)} < I_P < I_{PR(max)}$	–	400	–	mV/A
Zero-Current Output Voltage	$V_{IOUT(Q)}$	Bidirectional, $I_P = 0$ A	–	2.5	–	V
Accuracy Performance						
Total Output Error ²	E_{TOT}	$I_P = I_{PR(max)}$, $T_j = -40^\circ\text{C}$ to 150°C	-2	± 1	2	%
Total Output Error Components³ $E_{TOT} = E_{SENS} + 100 \times V_{OE} / (\text{Sens} \times I_P)$						
Sensitivity Error	E_{sens}	$I_P = I_{PR(max)}$, $T_j = -40^\circ\text{C}$ to 150°C	-1.5	± 1	1.5	%
Offset Voltage	V_{OE}	$I_P = 0$ A, $T_j = -40^\circ\text{C}$ to 150°C	-10	± 6	10	mV
Lifetime Drift Characteristics						
Sensitivity Error Lifetime Drift	E_{sens_drift}			± 1		%
Total Output Error Lifetime Drift	E_{tot_drift}			± 1		%

¹ Typical values with +/- are 3 sigma values

² Percentage of I_P , with $I_P = I_{PR(max)}$.

³ A single part will not have both the maximum/minimum sensitivity error and maximum/minimum offset voltage, as that would violate the maximum/minimum total output error specification. Also, 3 sigma distribution values are combined by taking the square root of the sum of the squares. See Application Information section.

HC70105CU5

unless otherwise specified

Characteristic	Symbol	Test Conditions	Min.	Typ. ¹	Max.	Unit
Nominal Performance						
Supply Voltage	V _{CC}		4.5	–	5.5	V
Current-Sensing Range	I _{PR}		0	–	5	A
Sensitivity	Sens	$I_{PR(min)} < I_P < I_{PR(max)}$	–	480	–	mV/A
Zero-Current Output Voltage	V _{IOUT(Q)}	Unidirectional, I _P = 0 A	–	0.45	–	V
Accuracy Performance						
Total Output Error ²	E _{TOT}	I _P = I _{PR(max)} , T _j = -40°C to 150°C	-2.5	±1.5	2.5	%
Total Output Error Components³ E_{TOT} = E_{SENS} + 100 × V_{OE}/(Sens × I_P)						
Sensitivity Error	E _{sens}	I _P = I _{PR(max)} , T _j = -40°C to 150°C	-2	±1	2	%
Offset Voltage	V _{OE}	I _P = 0 A, T _j = -40°C to 150°C	-15	±7	15	mV
Lifetime Drift Characteristics						
Sensitivity Error Lifetime Drift	E _{sens_drift}			±1		%
Total Output Error Lifetime Drift	E _{tot_drift}			±1		%

¹ Typical values with +/- are 3 sigma values

² Percentage of I_P, with I_P = I_{PR(max)}.

³ A single part will not have both the maximum/minimum sensitivity error and maximum/minimum offset voltage, as that would violate the maximum/minimum total output error specification. Also, 3 sigma distribution values are combined by taking the square root of the sum of the squares. See Application Information section.

HC70105CU3

unless otherwise specified

Characteristic	Symbol	Test Conditions	Min.	Typ. ¹	Max.	Unit
Nominal Performance						
Supply Voltage	V _{CC}		3	–	3.6	V
Current-Sensing Range	I _{PR}		0	–	5	A
Sensitivity	Sens	$I_{PR(min)} < I_P < I_{PR(max)}$	–	480	–	mV/A
Zero-Current Output Voltage	V _{IOUT(Q)}	Unidirectional, I _P = 0 A	–	0.45	–	V
Accuracy Performance						
Total Output Error ²	E _{TOT}	I _P = I _{PR(max)} , T _j = -40°C to 150°C	-2.5	±1.5	2.5	%
Total Output Error Components³ E_{TOT} = E_{SENS} + 100 × V_{OE}/(Sens × I_P)						
Sensitivity Error	E _{sens}	I _P = I _{PR(max)} , T _j = -40°C to 150°C	-2	±1	2	%
Offset Voltage	V _{OE}	I _P = 0 A, T _j = -40°C to 150°C	-15	±7	15	mV
Lifetime Drift Characteristics						
Sensitivity Error Lifetime Drift	E _{sens_drift}			±1		%
Total Output Error Lifetime Drift	E _{tot_drift}			±1		%

¹ Typical values with +/- are 3 sigma values

² Percentage of I_P, with I_P = I_{PR(max)}.

³ A single part will not have both the maximum/minimum sensitivity error and maximum/minimum offset voltage, as that would violate the maximum/minimum total output error specification. Also, 3 sigma distribution values are combined by taking the square root of the sum of the squares. See Application Information section.

HC70105CB3

unless otherwise specified

Characteristic	Symbol	Test Conditions	Min.	Typ. ¹	Max.	Unit
Nominal Performance						
Supply Voltage	V_{CC}		3	–	3.6	V
Current-Sensing Range	I_{PR}		-5	–	5	A
Sensitivity	Sens	$I_{PR(min)} < I_P < I_{PR(max)}$	–	264	–	mV/A
Zero-Current Output Voltage	$V_{IOUT(Q)}$	Bidirectional, $I_P = 0$ A	–	1.65	–	V
Accuracy Performance						
Total Output Error ²	E_{TOT}	$I_P = I_{PR(max)}$, $T_j = -40^\circ\text{C}$ to 150°C	-2	± 1	2	%
Total Output Error Components³ $E_{TOT} = E_{SENS} + 100 \times V_{OE} / (\text{Sens} \times I_P)$						
Sensitivity Error	E_{sens}	$I_P = I_{PR(max)}$, $T_j = -40^\circ\text{C}$ to 150°C	-1.5	± 1	1.5	%
Offset Voltage	V_{OE}	$I_P = 0$ A, $T_j = -40^\circ\text{C}$ to 150°C	-10	± 6	10	mV
Lifetime Drift Characteristics						
Sensitivity Error Lifetime Drift	E_{sens_drift}			± 1		%
Total Output Error Lifetime Drift	E_{tot_drift}			± 1		%

¹ Typical values with +/- are 3 sigma values

² Percentage of I_P , with $I_P = I_{PR(max)}$.

³ A single part will not have both the maximum/minimum sensitivity error and maximum/minimum offset voltage, as that would violate the maximum/minimum total output error specification. Also, 3 sigma distribution values are combined by taking the square root of the sum of the squares. See Application Information section.

HC70110AU5

unless otherwise specified

Characteristic	Symbol	Test Conditions	Min.	Typ. ¹	Max.	Unit
Nominal Performance						
Supply Voltage	V _{CC}		4.5	–	5.5	V
Current-Sensing Range	I _{PR}		0	–	10	A
Sensitivity	Sens	$ I_{PR(min)} < I < I_{PR(max)} $, VCC = 5V	–	370	–	mV/A
Zero-Current Output Voltage	V _{IOUT(Q)}	Unidirectional, I _P = 0 A, VCC = 5V	–	0.65	–	V
Accuracy Performance						
Total Output Error ²	E _{TOT}	I _P = I _{PR(max)} , T _j = -40°C to 150°C	-2.5	±1.5	2.5	%
Total Output Error Components³ E_{TOT} = E_{SENS} + 100 × V_{OE}/(Sens × I_P)						
Sensitivity Error	E _{sens}	I _P = I _{PR(max)} , T _j = -40°C to 150°C	-2	±1	2	%
Offset Voltage	V _{OE}	I _P = 0 A, T _j = -40°C to 150°C	-15	±7	15	mV
Lifetime Drift Characteristics						
Sensitivity Error Lifetime Drift	E _{sens_drift}			±1		%
Total Output Error Lifetime Drift	E _{tot_drift}			±1		%

¹ Typical values with +/- are 3 sigma values

² Percentage of I_P, with I_P = I_{PR(max)}.

³ A single part will not have both the maximum/minimum sensitivity error and maximum/minimum offset voltage, as that would violate the maximum/minimum total output error specification. Also, 3 sigma distribution values are combined by taking the square root of the sum of the squares. See Application Information section.

HC70110AU3

unless otherwise specified

Characteristic	Symbol	Test Conditions	Min.	Typ. ¹	Max.	Unit
Nominal Performance						
Supply Voltage	V _{CC}		3	–	3.6	V
Current-Sensing Range	I _{PR}		0	–	10	A
Sensitivity	Sens	$ \frac{\Delta I}{I} < I$ PR(min) P PR(max) , VCC = 3.3V	–	240	–	mV/A
Zero-Current Output Voltage	V _{IOUT(Q)}	Unidirectional, I _P = 0 A, VCC = 3.3V	–	0.45	–	V
Accuracy Performance						
Total Output Error ²	E _{TOT}	I _P = I _{PR(max)} , T _j = -40°C to 150°C	-2.5	±1.5	2.5	%
Total Output Error Components³ E_{TOT} = E_{SENS} + 100 × V_{OE}/(Sens × I_P)						
Sensitivity Error	E _{sens}	I _P = I _{PR(max)} , T _j = -40°C to 150°C	-2	±1	2	%
Offset Voltage	V _{OE}	I _P = 0 A, T _j = -40°C to 150°C	-15	±7	15	mV
Lifetime Drift Characteristics						
Sensitivity Error Lifetime Drift	E _{sens_drift}			±1		%
Total Output Error Lifetime Drift	E _{tot_drift}			±1		%

¹ Typical values with +/- are 3 sigma values

² Percentage of I_P, with I_P = I_{PR(max)}.

³ A single part will not have both the maximum/minimum sensitivity error and maximum/minimum offset voltage, as that would violate the maximum/minimum total output error specification. Also, 3 sigma distribution values are combined by taking the square root of the sum of the squares. See Application Information section.

HC70110AB5

unless otherwise specified

Characteristic	Symbol	Test Conditions	Min.	Typ. ¹	Max.	Unit
Nominal Performance						
Supply Voltage	V _{CC}		4.5	–	5.5	V
Current-Sensing Range	I _{PR}		-10	–	10	A
Sensitivity	Sens	$ I_{PR(min)} < I < I_{PR(max)} $, V _{CC} = 5V	–	200	–	mV/A
Zero-Current Output Voltage	V _{IOUT(Q)}	Bidirectional, I _P = 0 A, V _{CC} = 5V	–	V _{CC} × 0.5	–	V
Accuracy Performance						
Total Output Error ²	E _{TOT}	I _P = I _{PR(max)} , T _j = -40°C to 150°C	-2	±1	2	%
Total Output Error Components³ E_{TOT} = E_{SENS} + 100 × V_{OE} / (Sens × I_P)						
Sensitivity Error	E _{sens}	I _P = I _{PR(max)} , T _j = -40°C to 150°C	-1.5	±1	1.5	%
Offset Voltage	V _{OE}	I _P = 0 A, T _j = -40°C to 150°C	-10	±6	10	mV
Lifetime Drift Characteristics						
Sensitivity Error Lifetime Drift	E _{sens_drift}			±1		%
Total Output Error Lifetime Drift	E _{tot_drift}			±1		%

¹ Typical values with +/- are 3 sigma values

² Percentage of I_P, with I_P = I_{PR(max)}.

³ A single part will not have both the maximum/minimum sensitivity error and maximum/minimum offset voltage, as that would violate the maximum/minimum total output error specification. Also, 3 sigma distribution values are combined by taking the square root of the sum of the squares. See Application Information section.

HC70110AB3

unless otherwise specified

Characteristic	Symbol	Test Conditions	Min.	Typ. ¹	Max.	Unit
Nominal Performance						
Supply Voltage	V_{CC}		3	–	3.6	V
Current-Sensing Range	I_{PR}		-10	–	10	A
Sensitivity	Sens	$ I_{PR(min)} < I < I_{PR(max)} $, $V_{CC} = 3.3V$	–	132	–	mV/A
Zero-Current Output Voltage	$V_{IOUT(Q)}$	Bidirectional, $I_P = 0 A$, $V_{CC} = 3.3V$	–	$V_{CC} \times 0.5$	–	V
Accuracy Performance						
Total Output Error ²	E_{TOT}	$I_P = I_{PR(max)}$, $T_j = -40^\circ C$ to $150^\circ C$	–2	± 1	2	%
Total Output Error Components³ $E_{TOT} = E_{SENS} + 100 \times V_{OE} / (Sens \times I_P)$						
Sensitivity Error	E_{sens}	$I_P = I_{PR(max)}$, $T_j = -40^\circ C$ to $150^\circ C$	–1.5	± 1	1.5	%
Offset Voltage	V_{OE}	$I_P = 0 A$, $T_j = -40^\circ C$ to $150^\circ C$	–10	± 6	10	mV
Lifetime Drift Characteristics						
Sensitivity Error Lifetime Drift	E_{sens_drift}			± 1		%
Total Output Error Lifetime Drift	E_{tot_drift}			± 1		%

¹ Typical values with +/- are 3 sigma values

² Percentage of I_P , with $I_P = I_{PR(max)}$.

³ A single part will not have both the maximum/minimum sensitivity error and maximum/minimum offset voltage, as that would violate the maximum/minimum total output error specification. Also, 3 sigma distribution values are combined by taking the square root of the sum of the squares. See Application Information section.

HC70110BU5

unless otherwise specified

Characteristic	Symbol	Test Conditions	Min.	Typ. ¹	Max.	Unit
Nominal Performance						
Supply Voltage	V _{CC}		4.5	–	5.5	V
Current-Sensing Range	I _{PR}		0	–	10	A
Sensitivity	Sens	$I_{PR(min)} < I_P < I_{PR(max)}$	–	370	–	mV/A
Zero-Current Output Voltage	V _{IOUT(Q)}	Unidirectional, I _P = 0 A	–	0.65	–	V
Accuracy Performance						
Total Output Error ²	E _{TOT}	I _P = I _{PR(max)} , T _j = -40°C to 150°C	-2.5	±1.5	2.5	%
Total Output Error Components³ E_{TOT} = E_{SENS} + 100 × V_{OE} / (Sens × I_P)						
Sensitivity Error	E _{sens}	I _P = I _{PR(max)} , T _j = -40°C to 150°C	-2	±1	2	%
Offset Voltage	V _{OE}	I _P = 0 A, T _j = -40°C to 150°C	-15	±7	15	mV
Lifetime Drift Characteristics						
Sensitivity Error Lifetime Drift	E _{sens_drift}			±1		%
Total Output Error Lifetime Drift	E _{tot_drift}			±1		%

¹ Typical values with +/- are 3 sigma values

² Percentage of I_P, with I_P = I_{PR(max)}.

³ A single part will not have both the maximum/minimum sensitivity error and maximum/minimum offset voltage, as that would violate the maximum/minimum total output error specification. Also, 3 sigma distribution values are combined by taking the square root of the sum of the squares. See Application Information section.

HC70110BB5 Range L, valid at T_j unless otherwise specified

Characteristic	Symbol	Test Conditions	Min.	Typ. ¹	Max.	Unit
Nominal Performance						
Supply Voltage	V_{CC}		4.5	–	5.5	V
Current-Sensing Range	I_{PR}		-10	–	10	A
Sensitivity	Sens	$I_{PR(min)} < I_P < I_{PR(max)}$	–	200	–	mV/A
Zero-Current Output Voltage	$V_{IOUT(Q)}$	Bidirectional, $I_P = 0$ A	–	2.5	–	V
Accuracy Performance						
Total Output Error ²	E_{TOT}	$I_P = I_{PR(max)}$, $T_j = -40^\circ\text{C}$ to 150°C	-2	± 1	2	%
Total Output Error Components³ $E_{TOT} = E_{SENS} + 100 \times V_{OE} / (\text{Sens} \times I_P)$						
Sensitivity Error	E_{sens}	$I_P = I_{PR(max)}$, $T_j = -40^\circ\text{C}$ to 150°C	-1.5	± 1	1.5	%
Offset Voltage	V_{OE}	$I_P = 0$ A, $T_j = -40^\circ\text{C}$ to 150°C	-10	± 6	10	mV
Lifetime Drift Characteristics						
Sensitivity Error Lifetime Drift	E_{sens_drift}			± 1		%
Total Output Error Lifetime Drift	E_{tot_drift}			± 1		%

¹ Typical values with +/- are 3 sigma values

² Percentage of I_P , with $I_P = I_{PR(max)}$.

³ A single part will not have both the maximum/minimum sensitivity error and maximum/minimum offset voltage, as that would violate the maximum/minimum total output error specification. Also, 3 sigma distribution values are combined by taking the square root of the sum of the squares. See Application Information section.

HC70110CU3

unless otherwise specified

Characteristic	Symbol	Test Conditions	Min.	Typ. ¹	Max.	Unit
Nominal Performance						
Supply Voltage	V _{CC}		3	–	3.6	V
Current-Sensing Range	I _{PR}		0	–	10	A
Sensitivity	Sens	$I_{PR(min)} < I_P < I_{PR(max)}$	–	240	–	mV/A
Zero-Current Output Voltage	V _{IOUT(Q)}	Unidirectional, I _P = 0 A	–	0.45	–	V
Accuracy Performance						
Total Output Error ²	E _{TOT}	I _P = I _{PR(max)} , T _j = -40°C to 150°C	-2.5	±1.5	2.5	%
Total Output Error Components³ E_{TOT} = E_{SENS} + 100 × V_{OE}/(Sens × I_P)						
Sensitivity Error	E _{sens}	I _P = I _{PR(max)} , T _j = -40°C to 150°C	-2	±1	2	%
Offset Voltage	V _{OE}	I _P = 0 A, T _j = -40°C to 150°C	-15	±7	15	mV
Lifetime Drift Characteristics						
Sensitivity Error Lifetime Drift	E _{sens_drift}			±1		%
Total Output Error Lifetime Drift	E _{tot_drift}			±1		%

¹ Typical values with +/- are 3 sigma values

² Percentage of I_P, with I_P = I_{PR(max)}.

³ A single part will not have both the maximum/minimum sensitivity error and maximum/minimum offset voltage, as that would violate the maximum/minimum total output error specification. Also, 3 sigma distribution values are combined by taking the square root of the sum of the squares. See Application Information section.

HC70110CB5* Performance Characteristics Range L, valid at T_j

unless otherwise specified

Characteristic	Symbol	Test Conditions	Min.	Typ. ¹	Max.	Unit
Nominal Performance						
Supply Voltage	V _{CC}		4.5	–	5.5	V
Current-Sensing Range	I _{PR}		-10	–	10	A
Sensitivity	Sens	$I_{PR(min)} < I < I_{PR(max)}$	–	132	–	mV/A
Zero-Current Output Voltage	V _{IOUT(Q)}	Bidirectional, I _P = 0 A	–	1.65	–	V
Accuracy Performance						
Total Output Error ²	E _{TOT}	I _P = I _{PR(max)} , T _j = -40°C to 150°C	-2	±1	2	%
Total Output Error Components³ E_{TOT} = E_{SENS} + 100 × V_{OE}/(Sens × I_P)						
Sensitivity Error	E _{sens}	I _P = I _{PR(max)} , T _j = -40°C to 150°C	-1.5	±1	1.5	%
Offset Voltage	V _{OE}	I _P = 0 A, T _j = -40°C to 150°C	-10	±6	10	mV
Lifetime Drift Characteristics						
Sensitivity Error Lifetime Drift	E _{sens_drift}			±1		%
Total Output Error Lifetime Drift	E _{tot_drift}			±1		%

¹ Typical values with +/- are 3 sigma values

² Percentage of I_P, with I_P = I_{PR(max)}.

³ A single part will not have both the maximum/minimum sensitivity error and maximum/minimum offset voltage, as that would violate the maximum/minimum total output error specification. Also, 3 sigma distribution values are combined by taking the square root of the sum of the squares. See Application Information section.

HC70110CB3

unless otherwise specified

Characteristic	Symbol	Test Conditions	Min.	Typ. ¹	Max.	Unit
Nominal Performance						
Supply Voltage	V_{CC}		3	–	3.6	V
Current-Sensing Range	I_{PR}		-10	–	10	A
Sensitivity	Sens	$I_{PR(min)} < I_P < I_{PR(max)}$	–	132	–	mV/A
Zero-Current Output Voltage	$V_{IOUT(Q)}$	Bidirectional, $I_P = 0$ A	–	1.65	–	V
Accuracy Performance						
Total Output Error ²	E_{TOT}	$I_P = I_{PR(max)}$, $T_j = -40^{\circ}\text{C}$ to 150°C	-2	± 1	2	%
Total Output Error Components³ $E_{TOT} = E_{SENS} + 100 \times V_{OE}/(\text{Sens} \times I_P)$						
Sensitivity Error	E_{sens}	$I_P = I_{PR(max)}$, $T_j = -40^{\circ}\text{C}$ to 150°C	-1.5	± 1	1.5	%
Offset Voltage	V_{OE}	$I_P = 0$ A, $T_j = -40^{\circ}\text{C}$ to 150°C	-10	± 6	10	mV
Lifetime Drift Characteristics						
Sensitivity Error Lifetime Drift	E_{sens_drift}			± 1		%
Total Output Error Lifetime Drift	E_{tot_drift}			± 1		%

¹ Typical values with +/- are 3 sigma values

² Percentage of I_P , with $I_P = I_{PR(max)}$.

³ A single part will not have both the maximum/minimum sensitivity error and maximum/minimum offset voltage, as that would violate the maximum/minimum total output error specification. Also, 3 sigma distribution values are combined by taking the square root of the sum of the squares. See Application Information section.

HC70112AB5* Performance Characteristics Range L, valid at T_j

unless otherwise specified

Characteristic	Symbol	Test Conditions	Min.	Typ. ¹	Max.	Unit
Nominal Performance						
Supply Voltage	V _{CC}		4.5	–	5.5	V
Current-Sensing Range	I _{PR}		-12.5	–	12.5	A
Sensitivity	Sens	$ I_{PR(min)} < I < I_{PR(max)} $, VCC = 5V	–	110	–	mV/A
Zero-Current Output Voltage	V _{IOUT(Q)}	Bidirectional, I _P = 0 A, VCC = 5V	–	V _{CC} × 0.5	–	V
Accuracy Performance						
Total Output Error ²	E _{TOT}	I _P = I _{PR(max)} , T _j = -40°C to 150°C	-2	±1	2	%
Total Output Error Components³ E_{TOT} = E_{SENS} + 100 × V_{OE}/(Sens × I_P)						
Sensitivity Error	E _{sens}	I _P = I _{PR(max)} , T _j = -40°C to 150°C	-1.5	±1	1.5	%
Offset Voltage	V _{OE}	I _P = 0 A, T _j = -40°C to 150°C	-10	±6	10	mV
Lifetime Drift Characteristics						
Sensitivity Error Lifetime Drift	E _{sens_drift}			±1		%
Total Output Error Lifetime Drift	E _{tot_drift}			±1		%

¹ Typical values with +/- are 3 sigma values

² Percentage of I_P, with I_P = I_{PR(max)}.

³ A single part will not have both the maximum/minimum sensitivity error and maximum/minimum offset voltage, as that would violate the maximum/minimum total output error specification. Also, 3 sigma distribution values are combined by taking the square root of the sum of the squares. See Application Information section.

HC70112AB3

unless otherwise specified

Characteristic	Symbol	Test Conditions	Min.	Typ. ¹	Max.	Unit
Nominal Performance						
Supply Voltage	V _{CC}		3	–	3.6	V
Current-Sensing Range	I _{PR}		-12.5	–	12.5	A
Sensitivity	Sens	$ I_{PR(min)} < I < I_{PR(max)} $, V _{CC} = 3.3V	–	110	–	mV/A
Zero-Current Output Voltage	V _{IOUT(Q)}	Bidirectional, I _P = 0 A, V _{CC} = 3.3V	–	V _{CC} × 0.5	–	V
Accuracy Performance						
Total Output Error ²	E _{TOT}	I _P = I _{PR(max)} , T _j = -40°C to 150°C	-2	±1	2	%
Total Output Error Components³ E_{TOT} = E_{SENS} + 100 × V_{OE} / (Sens × I_P)						
Sensitivity Error	E _{SENS}	I _P = I _{PR(max)} , T _j = -40°C to 150°C	-1.5	±1	1.5	%
Offset Voltage	V _{OE}	I _P = 0 A, T _j = -40°C to 150°C	-10	±6	10	mV
Lifetime Drift Characteristics						
Sensitivity Error Lifetime Drift	E _{SENS_drift}			±1		%
Total Output Error Lifetime Drift	E _{TOT_drift}			±1		%

¹ Typical values with +/- are 3 sigma values

² Percentage of I_P, with I_P = I_{PR(max)}.

³ A single part will not have both the maximum/minimum sensitivity error and maximum/minimum offset voltage, as that would violate the maximum/minimum total output error specification. Also, 3 sigma distribution values are combined by taking the square root of the sum of the squares. See Application Information section.

HC70120AU5* Performance Characteristics: T_A Range L, valid at T_j = -40°C to 150°C, unless otherwise specified

Characteristic	Symbol	Test Conditions	Min.	Typ. ¹	Max.	Unit
Nominal Performance						
Supply Voltage	V _{CC}		4.5	–	5.5	V
Current-Sensing Range	I _{PR}		0	–	20	A
Sensitivity	Sens	$I_{PR(min)} < I < I_{PR(max)}$, V _{CC} = 5V	–	110	–	mV/A
Zero-Current Output Voltage	V _{IOUT(Q)}	Unidirectional, I _P = 0 A, V _{CC} = 5V	–	V _{CC} × 0.1	–	V
Accuracy Performance						
Total Output Error ²	E _{TOT}	I _P = I _{PR(max)} , T _j = -40°C to 150°C	-2	±0.7	2	%
Total Output Error Components³ E_{TOT} = E_{SENS} + 100 × V_{OE} / (Sens × I_P)						
Sensitivity Error	E _{sens}	I _P = I _{PR(max)} , T _j = -40°C to 150°C	-1.5	±0.7	1.5	%
Offset Voltage	V _{OE}	I _P = 0 A, T _j = -40°C to 150°C	-10	±6	10	mV
Lifetime Drift Characteristics						
Sensitivity Error Lifetime Drift	E _{sens_drift}			±1		%
Total Output Error Lifetime Drift	E _{tot_drift}			±1		%

¹ Typical values with +/- are 3 sigma values

² Percentage of I_P, with I_P = I_{PR(max)}.

³ A single part will not have both the maximum/minimum sensitivity error and maximum/minimum offset voltage, as that would violate the maximum/minimum total output error specification. Also, 3 sigma distribution values are combined by taking the square root of the sum of the squares. See Application Information section.

HC70120AU3

unless otherwise specified

Characteristic	Symbol	Test Conditions	Min.	Typ. ¹	Max.	Unit
Nominal Performance						
Supply Voltage	V _{CC}		3	–	3.6	V
Current-Sensing Range	I _{PR}		0	–	20	A
Sensitivity	Sens	$ I_{PR(min)} < I < I_{PR(max)} $, VCC = 3.3V	–	132	–	mV/A
Zero-Current Output Voltage	V _{IOUT(Q)}	Unidirectional, I _P = 0 A, VCC = 3.3V	–	V _{CC} × 0.1	–	V
Accuracy Performance						
Total Output Error ²	E _{TOT}	I _P = I _{PR(max)} , T _j = -40°C to 150°C	-2	±0.7	2	%
Total Output Error Components³ E_{TOT} = E_{SENS} + 100 × V_{OE} / (Sens × I_P)						
Sensitivity Error	E _{sens}	I _P = I _{PR(max)} , T _j = -40°C to 150°C	-1.5	±0.7	1.5	%
Offset Voltage	V _{OE}	I _P = 0 A, T _j = -40°C to 150°C	-10	±6	10	mV
Lifetime Drift Characteristics						
Sensitivity Error Lifetime Drift	E _{sens_drift}			±1		%
Total Output Error Lifetime Drift	E _{tot_drift}			±1		%

¹ Typical values with +/- are 3 sigma values

² Percentage of I_P, with I_P = I_{PR(max)}.

³ A single part will not have both the maximum/minimum sensitivity error and maximum/minimum offset voltage, as that would violate the maximum/minimum total output error specification. Also, 3 sigma distribution values are combined by taking the square root of the sum of the squares. See Application Information section.

HC70120AB5

unless otherwise specified

Characteristic	Symbol	Test Conditions	Min.	Typ. ¹	Max.	Unit
Nominal Performance						
Supply Voltage	V_{CC}		4.5	–	5.5	V
Current-Sensing Range	I_{PR}		-20	–	20	A
Sensitivity	Sens	$ I_{PR(min)} < I < I_{PR(max)} $, $V_{CC} = 5V$	–	100	–	mV/A
Zero-Current Output Voltage	$V_{IOUT(Q)}$	Bidirectional, $I_P = 0 A$, $V_{CC} = 5V$	–	$V_{CC} \times 0.5$	–	V
Accuracy Performance						
Total Output Error ²	E_{TOT}	$I_P = I_{PR(max)}$, $T_j = -40^\circ C$ to $150^\circ C$	-2	± 0.8	2	%
Total Output Error Components³ $E_{TOT} = E_{SENS} + 100 \times V_{OE}/(Sens \times I_P)$						
Sensitivity Error	E_{sens}	$I_P = I_{PR(max)}$, $T_j = -40^\circ C$ to $150^\circ C$	-1.5	± 0.6	1.5	%
Offset Voltage	V_{OE}	$I_P = 0 A$, $T_j = -40^\circ C$ to $150^\circ C$	-10	± 5	10	mV
Lifetime Drift Characteristics						
Sensitivity Error Lifetime Drift	E_{sens_drift}			± 1		%
Total Output Error Lifetime Drift	E_{tot_drift}			± 1		%

¹ Typical values with +/- are 3 sigma values

² Percentage of I_P , with $I_P = I_{PR(max)}$.

³ A single part will not have both the maximum/minimum sensitivity error and maximum/minimum offset voltage, as that would violate the maximum/minimum total output error specification. Also, 3 sigma distribution values are combined by taking the square root of the sum of the squares. See Application Information section.

HC70120AB3

unless otherwise specified

Characteristic	Symbol	Test Conditions	Min.	Typ. ¹	Max.	Unit
Nominal Performance						
Supply Voltage	V_{CC}		3	–	3.6	V
Current-Sensing Range	I_{PR}		-20	–	20	A
Sensitivity	Sens	$ I_{PR(min)} < I < I_{PR(max)} $, $V_{CC} = 3.3V$	–	66	–	mV/A
Zero-Current Output Voltage	$V_{IOUT(Q)}$	Bidirectional, $I_P = 0 A$, $V_{CC} = 3.3V$	–	$V_{CC} \times 0.5$	–	V
Accuracy Performance						
Total Output Error ²	E_{TOT}	$I_P = I_{PR(max)}$, $T_j = -40^\circ C$ to $150^\circ C$	-2	± 0.8	2	%
Total Output Error Components³ $E_{TOT} = E_{SENS} + 100 \times V_{OE} / (Sens \times I_P)$						
Sensitivity Error	E_{sens}	$I_P = I_{PR(max)}$, $T_j = -40^\circ C$ to $150^\circ C$	-1.5	± 0.6	1.5	%
Offset Voltage	V_{OE}	$I_P = 0 A$, $T_j = -40^\circ C$ to $150^\circ C$	-10	± 5	10	mV
Lifetime Drift Characteristics						
Sensitivity Error Lifetime Drift	E_{sens_drift}			± 1		%
Total Output Error Lifetime Drift	E_{tot_drift}			± 1		%

¹ Typical values with +/- are 3 sigma values

² Percentage of I_P , with $I_P = I_{PR(max)}$.

³ A single part will not have both the maximum/minimum sensitivity error and maximum/minimum offset voltage, as that would violate the maximum/minimum total output error specification. Also, 3 sigma distribution values are combined by taking the square root of the sum of the squares. See Application Information section.

HC70120BU5

unless otherwise specified

Characteristic	Symbol	Test Conditions	Min.	Typ. ¹	Max.	Unit
Nominal Performance						
Supply Voltage	V _{CC}		4.5	–	5.5	V
Current-Sensing Range	I _{PR}		0	–	20	A
Sensitivity	Sens	$I_{PR(min)} < I < I_{PR(max)}$	–	200	–	mV/A
Zero-Current Output Voltage	V _{IOUT(Q)}	Unidirectional, I _P = 0 A	–	0.5	–	V
Accuracy Performance						
Total Output Error ²	E _{TOT}	I _P = I _{PR(max)} , T _j = -40°C to 150°C	-2	±0.7	2	%
Total Output Error Components³ E_{TOT} = E_{SENS} + 100 × V_{OE}/(Sens × I_P)						
Sensitivity Error	E _{sens}	I _P = I _{PR(max)} , T _j = -40°C to 150°C	-1.5	±0.7	1.5	%
Offset Voltage	V _{OE}	I _P = 0 A, T _j = -40°C to 150°C	-10	±6	10	mV
Lifetime Drift Characteristics						
Sensitivity Error Lifetime Drift	E _{sens_drift}			±1		%
Total Output Error Lifetime Drift	E _{tot_drift}			±1		%

¹ Typical values with +/- are 3 sigma values

² Percentage of I_P, with I_P = I_{PR(max)}.

³ A single part will not have both the maximum/minimum sensitivity error and maximum/minimum offset voltage, as that would violate the maximum/minimum total output error specification. Also, 3 sigma distribution values are combined by taking the square root of the sum of the squares. See Application Information section.

HC70120BB5 Range L, valid at T_j unless otherwise specified

Characteristic	Symbol	Test Conditions	Min.	Typ. ¹	Max.	Unit
Nominal Performance						
Supply Voltage	V_{CC}		4.5	–	5.5	V
Current-Sensing Range	I_{PR}		-20	–	20	A
Sensitivity	Sens	$I_{PR(min)} < I_P < I_{PR(max)}$	–	100	–	mV/A
Zero-Current Output Voltage	$V_{IOUT(Q)}$	Bidirectional, $I_P = 0$ A	–	2.5	–	V
Accuracy Performance						
Total Output Error ²	E_{TOT}	$I_P = I_{PR(max)}$, $T_j = -40^\circ\text{C}$ to 150°C	-2	± 0.8	2	%
Total Output Error Components³ $E_{TOT} = E_{SENS} + 100 \times V_{OE} / (\text{Sens} \times I_P)$						
Sensitivity Error	E_{sens}	$I_P = I_{PR(max)}$, $T_j = -40^\circ\text{C}$ to 150°C	-1.5	± 0.6	1.5	%
Offset Voltage	V_{OE}	$I_P = 0$ A, $T_j = -40^\circ\text{C}$ to 150°C	-10	± 5	10	mV
Lifetime Drift Characteristics						
Sensitivity Error Lifetime Drift	E_{sens_drift}			± 1		%
Total Output Error Lifetime Drift	E_{tot_drift}			± 1		%

¹ Typical values with +/- are 3 sigma values

² Percentage of I_P , with $I_P = I_{PR(max)}$.

³ A single part will not have both the maximum/minimum sensitivity error and maximum/minimum offset voltage, as that would violate the maximum/minimum total output error specification. Also, 3 sigma distribution values are combined by taking the square root of the sum of the squares. See Application Information section.

HC70120CU5

unless otherwise specified

Characteristic	Symbol	Test Conditions	Min.	Typ. ¹	Max.	Unit
Nominal Performance						
Supply Voltage	V _{CC}		4.5	–	5.5	V
Current-Sensing Range	I _{PR}		0	–	20	A
Sensitivity	Sens	$I_{PR(min)} < I_P < I_{PR(max)}$	–	132	–	mV/A
Zero-Current Output Voltage	V _{IOUT(Q)}	Unidirectional, I _P = 0 A	–	0.33	–	V
Accuracy Performance						
Total Output Error ²	E _{TOT}	I _P = I _{PR(max)} , T _j = -40°C to 150°C	-2	±0.7	2	%
Total Output Error Components³ E_{TOT} = E_{SENS} + 100 × V_{OE} / (Sens × I_P)						
Sensitivity Error	E _{sens}	I _P = I _{PR(max)} , T _j = -40°C to 150°C	-1.5	±0.7	1.5	%
Offset Voltage	V _{OE}	I _P = 0 A, T _j = -40°C to 150°C	-10	±6	10	mV
Lifetime Drift Characteristics						
Sensitivity Error Lifetime Drift	E _{sens_drift}			±1		%
Total Output Error Lifetime Drift	E _{tot_drift}			±1		%

¹ Typical values with +/- are 3 sigma values

² Percentage of I_P, with I_P = I_{PR(max)}.

³ A single part will not have both the maximum/minimum sensitivity error and maximum/minimum offset voltage, as that would violate the maximum/minimum total output error specification. Also, 3 sigma distribution values are combined by taking the square root of the sum of the squares. See Application Information section.

HC70120CU3

unless otherwise specified

Characteristic	Symbol	Test Conditions	Min.	Typ. ¹	Max.	Unit
Nominal Performance						
Supply Voltage	V_{CC}		3	–	3.6	V
Current-Sensing Range	I_{PR}		0	–	20	A
Sensitivity	Sens	$I_{PR(min)} < I_P < I_{PR(max)}$	–	132	–	mV/A
Zero-Current Output Voltage	$V_{IOUT(Q)}$	Unidirectional, $I_P = 0$ A	–	0.33	–	V
Accuracy Performance						
Total Output Error ²	E_{TOT}	$I_P = I_{PR(max)}$, $T_j = -40^\circ\text{C}$ to 150°C	–2	± 0.7	2	%
Total Output Error Components³ $E_{TOT} = E_{SENS} + 100 \times V_{OE} / (\text{Sens} \times I_P)$						
Sensitivity Error	E_{sens}	$I_P = I_{PR(max)}$, $T_j = -40^\circ\text{C}$ to 150°C	–1.5	± 0.7	1.5	%
Offset Voltage	V_{OE}	$I_P = 0$ A, $T_j = -40^\circ\text{C}$ to 150°C	–10	± 6	10	mV
Lifetime Drift Characteristics						
Sensitivity Error Lifetime Drift	E_{sens_drift}			± 1		%
Total Output Error Lifetime Drift	E_{tot_drift}			± 1		%

¹ Typical values with +/- are 3 sigma values

² Percentage of I_P , with $I_P = I_{PR(max)}$.

³ A single part will not have both the maximum/minimum sensitivity error and maximum/minimum offset voltage, as that would violate the maximum/minimum total output error specification. Also, 3 sigma distribution values are combined by taking the square root of the sum of the squares. See Application Information section.

HC70120CB5

unless otherwise specified

Characteristic	Symbol	Test Conditions	Min.	Typ. ¹	Max.	Unit
Nominal Performance						
Supply Voltage	V_{CC}		4.5	–	5.5	V
Current-Sensing Range	I_{PR}		-20	–	20	A
Sensitivity	Sens	$I_{PR(min)} < I_P < I_{PR(max)}$	–	66	–	mV/A
Zero-Current Output Voltage	$V_{IOUT(Q)}$	Bidirectional, $I_P = 0$ A	–	1.65	–	V
Accuracy Performance						
Total Output Error ²	E_{TOT}	$I_P = I_{PR(max)}$, $T_j = -40^\circ\text{C}$ to 150°C	-2	± 0.8	2	%
Total Output Error Components³ $E_{TOT} = E_{SENS} + 100 \times V_{OE} / (\text{Sens} \times I_P)$						
Sensitivity Error	E_{sens}	$I_P = I_{PR(max)}$, $T_j = -40^\circ\text{C}$ to 150°C	-1.5	± 0.6	1.5	%
Offset Voltage	V_{OE}	$I_P = 0$ A, $T_j = -40^\circ\text{C}$ to 150°C	-10	± 5	10	mV
Lifetime Drift Characteristics						
Sensitivity Error Lifetime Drift	E_{sens_drift}			± 1		%
Total Output Error Lifetime Drift	E_{tot_drift}			± 1		%

¹ Typical values with +/- are 3 sigma values

² Percentage of I_P , with $I_P = I_{PR(max)}$.

³ A single part will not have both the maximum/minimum sensitivity error and maximum/minimum offset voltage, as that would violate the maximum/minimum total output error specification. Also, 3 sigma distribution values are combined by taking the square root of the sum of the squares. See Application Information section.

HC70120CB3

unless otherwise specified

Characteristic	Symbol	Test Conditions	Min.	Typ. ¹	Max.	Unit
Nominal Performance						
Supply Voltage	V_{CC}		3	–	3.6	V
Current-Sensing Range	I_{PR}		-20	–	20	A
Sensitivity	Sens	$I_{PR(min)} < I_P < I_{PR(max)}$	–	66	–	mV/A
Zero-Current Output Voltage	$V_{IOUT(Q)}$	Bidirectional, $I_P = 0$ A	–	1.65	–	V
Accuracy Performance						
Total Output Error ²	E_{TOT}	$I_P = I_{PR(max)}$, $T_j = -40^\circ\text{C}$ to 150°C	-2	± 0.8	2	%
Total Output Error Components³ $E_{TOT} = E_{SENS} + 100 \times V_{OE} / (\text{Sens} \times I_P)$						
Sensitivity Error	E_{sens}	$I_P = I_{PR(max)}$, $T_j = -40^\circ\text{C}$ to 150°C	-1.5	± 0.6	1.5	%
Offset Voltage	V_{OE}	$I_P = 0$ A, $T_j = -40^\circ\text{C}$ to 150°C	-10	± 5	10	mV
Lifetime Drift Characteristics						
Sensitivity Error Lifetime Drift	E_{sens_drift}			± 1		%
Total Output Error Lifetime Drift	E_{tot_drift}			± 1		%

¹ Typical values with +/- are 3 sigma values

² Percentage of I_P , with $I_P = I_{PR(max)}$.

³ A single part will not have both the maximum/minimum sensitivity error and maximum/minimum offset voltage, as that would violate the maximum/minimum total output error specification. Also, 3 sigma distribution values are combined by taking the square root of the sum of the squares. See Application Information section.

HC70130AU5

unless otherwise specified

Characteristic	Symbol	Test Conditions	Min.	Typ. ¹	Max.	Unit
Nominal Performance						
Supply Voltage	V _{CC}		4.5	–	5.5	V
Current-Sensing Range	I _{PR}		0	–	30	A
Sensitivity	Sens	$ I_{PR(min)} < I < I_{PR(max)} $, V _{CC} = 5V	–	133	–	mV/A
Zero-Current Output Voltage	V _{IOUT(Q)}	Unidirectional, I _P = 0 A, V _{CC} = 5V	–	V _{CC} × 0.1	–	V
Accuracy Performance						
Total Output Error ²	E _{TOT}	I _P = I _{PR(max)} , T _j = -40°C to 150°C	-2	±0.7	2	%
Total Output Error Components³ E_{TOT} = E_{SENS} + 100 × V_{OE} / (Sens × I_P)						
Sensitivity Error	E _{sens}	I _P = I _{PR(max)} , T _j = -40°C to 150°C	-1.5	±0.7	1.5	%
Offset Voltage	V _{OE}	I _P = 0 A, T _j = -40°C to 150°C	-10	±6	10	mV
Lifetime Drift Characteristics						
Sensitivity Error Lifetime Drift	E _{sens_drift}			±1		%
Total Output Error Lifetime Drift	E _{tot_drift}			±1		%

¹ Typical values with +/- are 3 sigma values

² Percentage of I_P, with I_P = I_{PR(max)}.

³ A single part will not have both the maximum/minimum sensitivity error and maximum/minimum offset voltage, as that would violate the maximum/minimum total output error specification. Also, 3 sigma distribution values are combined by taking the square root of the sum of the squares. See Application Information section.

HC70130AU3

unless otherwise specified

Characteristic	Symbol	Test Conditions	Min.	Typ. ¹	Max.	Unit
Nominal Performance						
Supply Voltage	V_{CC}		3	–	3.6	V
Current-Sensing Range	I_{PR}		0	–	30	A
Sensitivity	Sens	$ I_{PR(min)} < I < I_{PR(max)} $, $V_{CC} = 3.3V$	–	88	–	mV/A
Zero-Current Output Voltage	$V_{IOUT(Q)}$	Unidirectional, $I_P = 0 A$, $V_{CC} = 3.3V$	–	$V_{CC} \times 0.1$	–	V
Accuracy Performance						
Total Output Error ²	E_{TOT}	$I_P = I_{PR(max)}$, $T_j = -40^\circ C$ to $150^\circ C$	–2	± 0.7	2	%
Total Output Error Components³ $E_{TOT} = E_{SENS} + 100 \times V_{OE} / (Sens \times I_P)$						
Sensitivity Error	E_{sens}	$I_P = I_{PR(max)}$, $T_j = -40^\circ C$ to $150^\circ C$	–1.5	± 0.7	1.5	%
Offset Voltage	V_{OE}	$I_P = 0 A$, $T_j = -40^\circ C$ to $150^\circ C$	–10	± 6	10	mV
Lifetime Drift Characteristics						
Sensitivity Error Lifetime Drift	E_{sens_drift}			± 1		%
Total Output Error Lifetime Drift	E_{tot_drift}			± 1		%

¹ Typical values with +/- are 3 sigma values

² Percentage of I_P , with $I_P = I_{PR(max)}$.

³ A single part will not have both the maximum/minimum sensitivity error and maximum/minimum offset voltage, as that would violate the maximum/minimum total output error specification. Also, 3 sigma distribution values are combined by taking the square root of the sum of the squares. See Application Information section.

HC70130AB5

unless otherwise specified

Characteristic	Symbol	Test Conditions	Min.	Typ. ¹	Max.	Unit
Nominal Performance						
Supply Voltage	V_{CC}		4.5	–	5.5	V
Current-Sensing Range	I_{PR}		-30	–	30	A
Sensitivity	Sens	$ I_{PR(min)} < I < I_{PR(max)} $, $V_{CC} = 5V$	–	66	–	mV/A
Zero-Current Output Voltage	$V_{IOUT(Q)}$	Bidirectional, $I_P = 0 A$, $V_{CC} = 5V$	–	$V_{CC} \times 0.5$	–	V
Accuracy Performance						
Total Output Error ²	E_{TOT}	$I_P = I_{PR(max)}$, $T_j = -40^\circ C$ to $150^\circ C$	-2	± 0.8	2	%
Total Output Error Components³ $E_{TOT} = E_{SENS} + 100 \times V_{OE} / (Sens \times I_P)$						
Sensitivity Error	E_{sens}	$I_P = I_{PR(max)}$, $T_j = -40^\circ C$ to $150^\circ C$	-1.5	± 0.8	1.5	%
Offset Voltage	V_{OE}	$I_P = 0 A$, $T_j = -40^\circ C$ to $150^\circ C$	-10	± 6	10	mV
Lifetime Drift Characteristics						
Sensitivity Error Lifetime Drift	E_{sens_drift}			± 1		%
Total Output Error Lifetime Drift	E_{tot_drift}			± 1		%

¹ Typical values with +/- are 3 sigma values

² Percentage of I_P , with $I_P = I_{PR(max)}$.

³ A single part will not have both the maximum/minimum sensitivity error and maximum/minimum offset voltage, as that would violate the maximum/minimum total output error specification. Also, 3 sigma distribution values are combined by taking the square root of the sum of the squares. See Application Information section.

HC70130AB3

unless otherwise specified

Characteristic	Symbol	Test Conditions	Min.	Typ. ¹	Max.	Unit
Nominal Performance						
Supply Voltage	V_{CC}		3	–	3.6	V
Current-Sensing Range	I_{PR}		-30	–	30	A
Sensitivity	Sens	$ I_{PR(min)} < I < I_{PR(max)} $, $V_{CC} = 3.3V$	–	44	–	mV/A
Zero-Current Output Voltage	$V_{IOUT(Q)}$	Bidirectional, $I_P = 0 A$, $V_{CC} = 3.3V$	–	$V_{CC} \times 0.5$	–	V
Accuracy Performance						
Total Output Error ²	E_{TOT}	$I_P = I_{PR(max)}$, $T_j = -40^\circ C$ to $150^\circ C$	-2	± 0.8	2	%
Total Output Error Components³ $E_{TOT} = E_{SENS} + 100 \times V_{OE} / (Sens \times I_P)$						
Sensitivity Error	E_{sens}	$I_P = I_{PR(max)}$, $T_j = -40^\circ C$ to $150^\circ C$	-1.5	± 0.8	1.5	%
Offset Voltage	V_{OE}	$I_P = 0 A$, $T_j = -40^\circ C$ to $150^\circ C$	-10	± 6	10	mV
Lifetime Drift Characteristics						
Sensitivity Error Lifetime Drift	E_{sens_drift}			± 1		%
Total Output Error Lifetime Drift	E_{tot_drift}			± 1		%

¹ Typical values with +/- are 3 sigma values

² Percentage of I_P , with $I_P = I_{PR(max)}$.

³ A single part will not have both the maximum/minimum sensitivity error and maximum/minimum offset voltage, as that would violate the maximum/minimum total output error specification. Also, 3 sigma distribution values are combined by taking the square root of the sum of the squares. See Application Information section.

HC70130BU5

unless otherwise specified

Characteristic	Symbol	Test Conditions	Min.	Typ. ¹	Max.	Unit
Nominal Performance						
Supply Voltage	V_{CC}		4.5	–	5.5	V
Current-Sensing Range	I_{PR}		0	–	30	A
Sensitivity	Sens	$I_{PR(min)} < I_P < I_{PR(max)}$	–	133	–	mV/A
Zero-Current Output Voltage	$V_{IOUT(Q)}$	Unidirectional, $I_P = 0$ A	–	0.5	–	V
Accuracy Performance						
Total Output Error ²	E_{TOT}	$I_P = I_{PR(max)}$, $T_j = -40^\circ\text{C}$ to 150°C	–2	± 0.7	2	%
Total Output Error Components³ $E_{TOT} = E_{SENS} + 100 \times V_{OE} / (\text{Sens} \times I_P)$						
Sensitivity Error	E_{sens}	$I_P = I_{PR(max)}$, $T_j = -40^\circ\text{C}$ to 150°C	–1.5	± 0.7	1.5	%
Offset Voltage	V_{OE}	$I_P = 0$ A, $T_j = -40^\circ\text{C}$ to 150°C	–10	± 6	10	mV
Lifetime Drift Characteristics						
Sensitivity Error Lifetime Drift	E_{sens_drift}			± 1		%
Total Output Error Lifetime Drift	E_{tot_drift}			± 1		%

¹ Typical values with +/- are 3 sigma values

² Percentage of I_P , with $I_P = I_{PR(max)}$.

³ A single part will not have both the maximum/minimum sensitivity error and maximum/minimum offset voltage, as that would violate the maximum/minimum total output error specification. Also, 3 sigma distribution values are combined by taking the square root of the sum of the squares. See Application Information section.

HC70130BB5

unless otherwise specified

Characteristic	Symbol	Test Conditions	Min.	Typ. ¹	Max.	Unit
Nominal Performance						
Supply Voltage	V_{CC}		4.5	–	5.5	V
Current-Sensing Range	I_{PR}		-30	–	30	A
Sensitivity	Sens	$I_{PR(min)} < I_P < I_{PR(max)}$	–	66	–	mV/A
Zero-Current Output Voltage	$V_{IOUT(Q)}$	Bidirectional, $I_P = 0$ A	–	2.5	–	V
Accuracy Performance						
Total Output Error ²	E_{TOT}	$I_P = I_{PR(max)}$, $T_j = -40^{\circ}\text{C}$ to 150°C	-2	± 0.8	2	%
Total Output Error Components³ $E_{TOT} = E_{SENS} + 100 \times V_{OE}/(\text{Sens} \times I_P)$						
Sensitivity Error	E_{sens}	$I_P = I_{PR(max)}$, $T_j = -40^{\circ}\text{C}$ to 150°C	-1.5	± 0.6	1.5	%
Offset Voltage	V_{OE}	$I_P = 0$ A, $T_j = -40^{\circ}\text{C}$ to 150°C	-10	± 5	10	mV
Lifetime Drift Characteristics						
Sensitivity Error Lifetime Drift	E_{sens_drift}			± 1		%
Total Output Error Lifetime Drift	E_{tot_drift}			± 1		%

¹ Typical values with +/- are 3 sigma values

² Percentage of I_P , with $I_P = I_{PR(max)}$.

³ A single part will not have both the maximum/minimum sensitivity error and maximum/minimum offset voltage, as that would violate the maximum/minimum total output error specification. Also, 3 sigma distribution values are combined by taking the square root of the sum of the squares. See Application Information section.

HC70130CU5

unless otherwise specified

Characteristic	Symbol	Test Conditions	Min.	Typ. ¹	Max.	Unit
Nominal Performance						
Supply Voltage	V _{CC}		4.5	–	5.5	V
Current-Sensing Range	I _{PR}		0	–	30	A
Sensitivity	Sens	$I_{PR(min)} < I_P < I_{PR(max)}$	–	88	–	mV/A
Zero-Current Output Voltage	V _{IOUT(Q)}	Unidirectional, I _P = 0 A	–	0.33	–	V
Accuracy Performance						
Total Output Error ²	E _{TOT}	I _P = I _{PR(max)} , T _j = -40°C to 150°C	-2	±0.7	2	%
Total Output Error Components³ E_{TOT} = E_{SENS} + 100 × V_{OE}/(Sens × I_P)						
Sensitivity Error	E _{sens}	I _P = I _{PR(max)} , T _j = -40°C to 150°C	-1.5	±0.7	1.5	%
Offset Voltage	V _{OE}	I _P = 0 A, T _j = -40°C to 150°C	-10	±6	10	mV
Lifetime Drift Characteristics						
Sensitivity Error Lifetime Drift	E _{sens_drift}			±1		%
Total Output Error Lifetime Drift	E _{tot_drift}			±1		%

¹ Typical values with +/- are 3 sigma values

² Percentage of I_P, with I_P = I_{PR(max)}.

³ A single part will not have both the maximum/minimum sensitivity error and maximum/minimum offset voltage, as that would violate the maximum/minimum total output error specification. Also, 3 sigma distribution values are combined by taking the square root of the sum of the squares. See Application Information section.

HC70130CU3

unless otherwise specified

Characteristic	Symbol	Test Conditions	Min.	Typ. ¹	Max.	Unit
Nominal Performance						
Supply Voltage	V_{CC}		3	–	3.6	V
Current-Sensing Range	I_{PR}		0	–	30	A
Sensitivity	Sens	$I_{PR(min)} < I_P < I_{PR(max)}$	–	88	–	mV/A
Zero-Current Output Voltage	$V_{IOUT(Q)}$	Unidirectional, $I_P = 0$ A	–	0.33	–	V
Accuracy Performance						
Total Output Error ²	E_{TOT}	$I_P = I_{PR(max)}$, $T_j = -40^{\circ}\text{C}$ to 150°C	–2	± 0.7	2	%
Total Output Error Components³ $E_{TOT} = E_{SENS} + 100 \times V_{OE} / (\text{Sens} \times I_P)$						
Sensitivity Error	E_{sens}	$I_P = I_{PR(max)}$, $T_j = -40^{\circ}\text{C}$ to 150°C	–1.5	± 0.7	1.5	%
Offset Voltage	V_{OE}	$I_P = 0$ A, $T_j = -40^{\circ}\text{C}$ to 150°C	–10	± 6	10	mV
Lifetime Drift Characteristics						
Sensitivity Error Lifetime Drift	E_{sens_drift}			± 1		%
Total Output Error Lifetime Drift	E_{tot_drift}			± 1		%

¹ Typical values with +/- are 3 sigma values

² Percentage of I_P , with $I_P = I_{PR(max)}$.

³ A single part will not have both the maximum/minimum sensitivity error and maximum/minimum offset voltage, as that would violate the maximum/minimum total output error specification. Also, 3 sigma distribution values are combined by taking the square root of the sum of the squares. See Application Information section.

HC70130CB5

unless otherwise specified

Characteristic	Symbol	Test Conditions	Min.	Typ. ¹	Max.	Unit
Nominal Performance						
Supply Voltage	V _{CC}		4.5	–	5.5	V
Current-Sensing Range	I _{PR}		-30	–	30	A
Sensitivity	Sens	$I_{PR(min)} < I_P < I_{PR(max)}$	–	44	–	mV/A
Zero-Current Output Voltage	V _{IOUT(Q)}	Bidirectional, I _P = 0 A	–	1.65	–	V
Accuracy Performance						
Total Output Error ²	E _{TOT}	I _P = I _{PR(max)} , T _j = -40°C to 150°C	-2	±0.8	2	%
Total Output Error Components³ E_{TOT} = E_{SENS} + 100 × V_{OE} / (Sens × I_P)						
Sensitivity Error	E _{sens}	I _P = I _{PR(max)} , T _j = -40°C to 150°C	-1.5	±0.6	1.5	%
Offset Voltage	V _{OE}	I _P = 0 A, T _j = -40°C to 150°C	-10	±5	10	mV
Lifetime Drift Characteristics						
Sensitivity Error Lifetime Drift	E _{sens_drift}			±1		%
Total Output Error Lifetime Drift	E _{tot_drift}			±1		%

¹ Typical values with +/- are 3 sigma values

² Percentage of I_P, with I_P = I_{PR(max)}.

³ A single part will not have both the maximum/minimum sensitivity error and maximum/minimum offset voltage, as that would violate the maximum/minimum total output error specification. Also, 3 sigma distribution values are combined by taking the square root of the sum of the squares. See Application Information section.

HC70130CB3

unless otherwise specified

Characteristic	Symbol	Test Conditions	Min.	Typ. ¹	Max.	Unit
Nominal Performance						
Supply Voltage	V_{CC}		3	–	3.6	V
Current-Sensing Range	I_{PR}		-30	–	30	A
Sensitivity	Sens	$I_{PR(min)} < I_P < I_{PR(max)}$	–	44	–	mV/A
Zero-Current Output Voltage	$V_{IOUT(Q)}$	Bidirectional, $I_P = 0$ A	–	1.65	–	V
Accuracy Performance						
Total Output Error ²	E_{TOT}	$I_P = I_{PR(max)}$, $T_j = -40^\circ\text{C}$ to 150°C	-2	± 0.8	2	%
Total Output Error Components³ $E_{TOT} = E_{SENS} + 100 \times V_{OE}/(\text{Sens} \times I_P)$						
Sensitivity Error	E_{sens}	$I_P = I_{PR(max)}$, $T_j = -40^\circ\text{C}$ to 150°C	-1.5	± 0.6	1.5	%
Offset Voltage	V_{OE}	$I_P = 0$ A, $T_j = -40^\circ\text{C}$ to 150°C	-10	± 5	10	mV
Lifetime Drift Characteristics						
Sensitivity Error Lifetime Drift	E_{sens_drift}			± 1		%
Total Output Error Lifetime Drift	E_{tot_drift}			± 1		%

¹ Typical values with +/- are 3 sigma values

² Percentage of I_P , with $I_P = I_{PR(max)}$.

³ A single part will not have both the maximum/minimum sensitivity error and maximum/minimum offset voltage, as that would violate the maximum/minimum total output error specification. Also, 3 sigma distribution values are combined by taking the square root of the sum of the squares. See Application Information section.

HC70140AU5

unless otherwise specified

Characteristic	Symbol	Test Conditions	Min.	Typ. ¹	Max.	Unit
Nominal Performance						
Supply Voltage	V_{CC}		4.5	–	5.5	V
Current-Sensing Range	I_{PR}		0	–	40	A
Sensitivity	Sens	$I_{PR(min)} < I < I_{PR(max)}$, $V_{CC} = 5V$	–	100	–	mV/A
Zero-Current Output Voltage	$V_{IOUT(Q)}$	Unidirectional, $I_P = 0 A$, $V_{CC} = 5V$	–	$V_{CC} \times 0.1$	–	V
Accuracy Performance						
Total Output Error ²	E_{TOT}	$I_P = I_{PR(max)}$, $T_j = -40^\circ C$ to $150^\circ C$	–2	± 0.7	2	%
Total Output Error Components³ $E_{TOT} = E_{SENS} + 100 \times V_{OE} / (Sens \times I_P)$						
Sensitivity Error	E_{sens}	$I_P = I_{PR(max)}$, $T_j = -40^\circ C$ to $150^\circ C$	–1.5	± 0.7	1.5	%
Offset Voltage	V_{OE}	$I_P = 0 A$, $T_j = -40^\circ C$ to $150^\circ C$	–10	± 6	10	mV
Lifetime Drift Characteristics						
Sensitivity Error Lifetime Drift	E_{sens_drift}			± 1		%
Total Output Error Lifetime Drift	E_{tot_drift}			± 1		%

¹ Typical values with +/- are 3 sigma values

² Percentage of I_P , with $I_P = I_{PR(max)}$.

³ A single part will not have both the maximum/minimum sensitivity error and maximum/minimum offset voltage, as that would violate the maximum/minimum total output error specification. Also, 3 sigma distribution values are combined by taking the square root of the sum of the squares. See Application Information section.

HC70140AU3

unless otherwise specified

Characteristic	Symbol	Test Conditions	Min.	Typ. ¹	Max.	Unit
Nominal Performance						
Supply Voltage	V_{CC}		3	–	3.6	V
Current-Sensing Range	I_{PR}		0	–	40	A
Sensitivity	Sens	$ I_{PR(min)} < I < I_{PR(max)} $, $V_{CC} = 3.3V$	–	66	–	mV/A
Zero-Current Output Voltage	$V_{IOUT(Q)}$	Unidirectional, $I_P = 0 A$, $V_{CC} = 3.3V$	–	$V_{CC} \times 0.1$	–	V
Accuracy Performance						
Total Output Error ²	E_{TOT}	$I_P = I_{PR(max)}$, $T_j = -40^\circ C$ to $150^\circ C$	–2	± 0.7	2	%
Total Output Error Components³ $E_{TOT} = E_{SENS} + 100 \times V_{OE} / (Sens \times I_P)$						
Sensitivity Error	E_{sens}	$I_P = I_{PR(max)}$, $T_j = -40^\circ C$ to $150^\circ C$	–1.5	± 0.7	1.5	%
Offset Voltage	V_{OE}	$I_P = 0 A$, $T_j = -40^\circ C$ to $150^\circ C$	–10	± 6	10	mV
Lifetime Drift Characteristics						
Sensitivity Error Lifetime Drift	E_{sens_drift}			± 1		%
Total Output Error Lifetime Drift	E_{tot_drift}			± 1		%

¹ Typical values with +/- are 3 sigma values

² Percentage of I_P , with $I_P = I_{PR(max)}$.

³ A single part will not have both the maximum/minimum sensitivity error and maximum/minimum offset voltage, as that would violate the maximum/minimum total output error specification. Also, 3 sigma distribution values are combined by taking the square root of the sum of the squares. See Application Information section.

HC70140AB5

unless otherwise specified

Characteristic	Symbol	Test Conditions	Min.	Typ. ¹	Max.	Unit
Nominal Performance						
Supply Voltage	V_{CC}		4.5	–	5.5	V
Current-Sensing Range	I_{PR}		-40	–	40	A
Sensitivity	Sens	$ I_{PR(min)} < I < I_{PR(max)} $, $V_{CC} = 5V$	–	50	–	mV/A
Zero-Current Output Voltage	$V_{IOUT(Q)}$	Bidirectional, $I_P = 0 A$, $V_{CC} = 5V$	–	$V_{CC} \times 0.5$	–	V
Accuracy Performance						
Total Output Error ²	E_{TOT}	$I_P = I_{PR(max)}$, $T_j = -40^\circ C$ to $150^\circ C$	-2	± 0.8	2	%
Total Output Error Components³ $E_{TOT} = E_{SENS} + 100 \times V_{OE} / (Sens \times I_P)$						
Sensitivity Error	E_{sens}	$I_P = I_{PR(max)}$, $T_j = -40^\circ C$ to $150^\circ C$	-1.5	± 0.6	1.5	%
Offset Voltage	V_{OE}	$I_P = 0 A$, $T_j = -40^\circ C$ to $150^\circ C$	-10	± 5	10	mV
Lifetime Drift Characteristics						
Sensitivity Error Lifetime Drift	E_{sens_drift}			± 1		%
Total Output Error Lifetime Drift	E_{tot_drift}			± 1		%

¹ Typical values with +/- are 3 sigma values

² Percentage of I_P , with $I_P = I_{PR(max)}$.

³ A single part will not have both the maximum/minimum sensitivity error and maximum/minimum offset voltage, as that would violate the maximum/minimum total output error specification. Also, 3 sigma distribution values are combined by taking the square root of the sum of the squares. See Application Information section.

HC70140AB3

unless otherwise specified

Characteristic	Symbol	Test Conditions	Min.	Typ. ¹	Max.	Unit
Nominal Performance						
Supply Voltage	V_{CC}		3	–	3.6	V
Current-Sensing Range	I_{PR}		-40	–	40	A
Sensitivity	Sens	$ I_{PR(min)} < I < I_{PR(max)} $, $V_{CC} = 3.3V$	–	33	–	mV/A
Zero-Current Output Voltage	$V_{IOUT(Q)}$	Bidirectional, $I_P = 0 A$, $V_{CC} = 3.3V$	–	$V_{CC} \times 0.5$	–	V
Accuracy Performance						
Total Output Error ²	E_{TOT}	$I_P = I_{PR(max)}$, $T_j = -40^\circ C$ to $150^\circ C$	-2	± 0.8	2	%
Total Output Error Components³ $E_{TOT} = E_{SENS} + 100 \times V_{OE} / (Sens \times I_P)$						
Sensitivity Error	E_{sens}	$I_P = I_{PR(max)}$, $T_j = -40^\circ C$ to $150^\circ C$	-1.5	± 0.6	1.5	%
Offset Voltage	V_{OE}	$I_P = 0 A$, $T_j = -40^\circ C$ to $150^\circ C$	-10	± 5	10	mV
Lifetime Drift Characteristics						
Sensitivity Error Lifetime Drift	E_{sens_drift}			± 1		%
Total Output Error Lifetime Drift	E_{tot_drift}			± 1		%

¹ Typical values with +/- are 3 sigma values

² Percentage of I_P , with $I_P = I_{PR(max)}$.

³ A single part will not have both the maximum/minimum sensitivity error and maximum/minimum offset voltage, as that would violate the maximum/minimum total output error specification. Also, 3 sigma distribution values are combined by taking the square root of the sum of the squares. See Application Information section.

HC70140BU5

unless otherwise specified

Characteristic	Symbol	Test Conditions	Min.	Typ. ¹	Max.	Unit
Nominal Performance						
Supply Voltage	V_{CC}		4.5	–	5.5	V
Current-Sensing Range	I_{PR}		0	–	40	A
Sensitivity	Sens	$I_{PR(min)} < I_P < I_{PR(max)}$	–	100	–	mV/A
Zero-Current Output Voltage	$V_{IOUT(Q)}$	Unidirectional, $I_P = 0$ A	–	0.5	–	V
Accuracy Performance						
Total Output Error ²	E_{TOT}	$I_P = I_{PR(max)}$, $T_j = -40^{\circ}\text{C}$ to 150°C	–2	± 0.7	2	%
Total Output Error Components³ $E_{TOT} = E_{SENS} + 100 \times V_{OE}/(\text{Sens} \times I_P)$						
Sensitivity Error	E_{sens}	$I_P = I_{PR(max)}$, $T_j = -40^{\circ}\text{C}$ to 150°C	–1.5	± 0.7	1.5	%
Offset Voltage	V_{OE}	$I_P = 0$ A, $T_j = -40^{\circ}\text{C}$ to 150°C	–10	± 6	10	mV
Lifetime Drift Characteristics						
Sensitivity Error Lifetime Drift	E_{sens_drift}			± 1		%
Total Output Error Lifetime Drift	E_{tot_drift}			± 1		%

¹ Typical values with +/- are 3 sigma values

² Percentage of I_P , with $I_P = I_{PR(max)}$.

³ A single part will not have both the maximum/minimum sensitivity error and maximum/minimum offset voltage, as that would violate the maximum/minimum total output error specification. Also, 3 sigma distribution values are combined by taking the square root of the sum of the squares. See Application Information section.

HC70140BB5

unless otherwise specified

Characteristic	Symbol	Test Conditions	Min.	Typ. ¹	Max.	Unit
Nominal Performance						
Supply Voltage	V_{CC}		4.5	–	5.5	V
Current-Sensing Range	I_{PR}		-40	–	40	A
Sensitivity	Sens	$I_{PR(min)} < I_P < I_{PR(max)}$	–	50	–	mV/A
Zero-Current Output Voltage	$V_{IOUT(Q)}$	Bidirectional, $I_P = 0$ A	–	2.5	–	V
Accuracy Performance						
Total Output Error ²	E_{TOT}	$I_P = I_{PR(max)}$, $T_j = -40^\circ\text{C}$ to 150°C	-2	± 0.8	2	%
Total Output Error Components³ $E_{TOT} = E_{SENS} + 100 \times V_{OE}/(\text{Sens} \times I_P)$						
Sensitivity Error	E_{sens}	$I_P = I_{PR(max)}$, $T_j = -40^\circ\text{C}$ to 150°C	-1.5	± 0.6	1.5	%
Offset Voltage	V_{OE}	$I_P = 0$ A, $T_j = -40^\circ\text{C}$ to 150°C	-10	± 5	10	mV
Lifetime Drift Characteristics						
Sensitivity Error Lifetime Drift	E_{sens_drift}			± 1		%
Total Output Error Lifetime Drift	E_{tot_drift}			± 1		%

¹ Typical values with +/- are 3 sigma values

² Percentage of I_P , with $I_P = I_{PR(max)}$.

³ A single part will not have both the maximum/minimum sensitivity error and maximum/minimum offset voltage, as that would violate the maximum/minimum total output error specification. Also, 3 sigma distribution values are combined by taking the square root of the sum of the squares. See Application Information section.

HC70140CU5

unless otherwise specified

Characteristic	Symbol	Test Conditions	Min.	Typ. ¹	Max.	Unit
Nominal Performance						
Supply Voltage	V _{CC}		4.5	–	5.5	V
Current-Sensing Range	I _{PR}		0	–	40	A
Sensitivity	Sens	$I_{PR(min)} < I_P < I_{PR(max)}$	–	66	–	mV/A
Zero-Current Output Voltage	V _{IOUT(Q)}	Unidirectional, I _P = 0 A	–	0.33	–	V
Accuracy Performance						
Total Output Error ²	E _{TOT}	I _P = I _{PR(max)} , T _j = -40°C to 150°C	-2	±0.7	2	%
Total Output Error Components³ E_{TOT} = E_{SENS} + 100 × V_{OE} / (Sens × I_P)						
Sensitivity Error	E _{sens}	I _P = I _{PR(max)} , T _j = -40°C to 150°C	-1.5	±0.7	1.5	%
Offset Voltage	V _{OE}	I _P = 0 A, T _j = -40°C to 150°C	-10	±6	10	mV
Lifetime Drift Characteristics						
Sensitivity Error Lifetime Drift	E _{sens_drift}			±1		%
Total Output Error Lifetime Drift	E _{tot_drift}			±1		%

¹ Typical values with +/- are 3 sigma values

² Percentage of I_P, with I_P = I_{PR(max)}.

³ A single part will not have both the maximum/minimum sensitivity error and maximum/minimum offset voltage, as that would violate the maximum/minimum total output error specification. Also, 3 sigma distribution values are combined by taking the square root of the sum of the squares. See Application Information section.

HC70140CU3

unless otherwise specified

Characteristic	Symbol	Test Conditions	Min.	Typ. ¹	Max.	Unit
Nominal Performance						
Supply Voltage	V_{CC}		3	–	3.6	V
Current-Sensing Range	I_{PR}		0	–	40	A
Sensitivity	Sens	$I_{PR(min)} < I_P < I_{PR(max)}$	–	66	–	mV/A
Zero-Current Output Voltage	$V_{IOUT(Q)}$	Unidirectional, $I_P = 0$ A	–	0.33	–	V
Accuracy Performance						
Total Output Error ²	E_{TOT}	$I_P = I_{PR(max)}$, $T_j = -40^{\circ}\text{C}$ to 150°C	–2	± 0.7	2	%
Total Output Error Components³ $E_{TOT} = E_{SENS} + 100 \times V_{OE}/(\text{Sens} \times I_P)$						
Sensitivity Error	E_{sens}	$I_P = I_{PR(max)}$, $T_j = -40^{\circ}\text{C}$ to 150°C	–1.5	± 0.7	1.5	%
Offset Voltage	V_{OE}	$I_P = 0$ A, $T_j = -40^{\circ}\text{C}$ to 150°C	–10	± 6	10	mV
Lifetime Drift Characteristics						
Sensitivity Error Lifetime Drift	E_{sens_drift}			± 1		%
Total Output Error Lifetime Drift	E_{tot_drift}			± 1		%

¹ Typical values with +/- are 3 sigma values

² Percentage of I_P , with $I_P = I_{PR(max)}$.

³ A single part will not have both the maximum/minimum sensitivity error and maximum/minimum offset voltage, as that would violate the maximum/minimum total output error specification. Also, 3 sigma distribution values are combined by taking the square root of the sum of the squares. See Application Information section.

HC70140CB5

unless otherwise specified

Characteristic	Symbol	Test Conditions	Min.	Typ. ¹	Max.	Unit
Nominal Performance						
Supply Voltage	V_{CC}		4.5	–	5.5	V
Current-Sensing Range	I_{PR}		-40	–	40	A
Sensitivity	Sens	$I_{PR(min)} < I_P < I_{PR(max)}$	–	33	–	mV/A
Zero-Current Output Voltage	$V_{IOUT(Q)}$	Bidirectional, $I_P = 0$ A	–	1.65	–	V
Accuracy Performance						
Total Output Error ²	E_{TOT}	$I_P = I_{PR(max)}$, $T_j = -40^\circ\text{C}$ to 150°C	-2	± 0.8	2	%
Total Output Error Components³ $E_{TOT} = E_{SENS} + 100 \times V_{OE}/(\text{Sens} \times I_P)$						
Sensitivity Error	E_{sens}	$I_P = I_{PR(max)}$, $T_j = -40^\circ\text{C}$ to 150°C	-1.5	± 0.6	1.5	%
Offset Voltage	V_{OE}	$I_P = 0$ A, $T_j = -40^\circ\text{C}$ to 150°C	-10	± 5	10	mV
Lifetime Drift Characteristics						
Sensitivity Error Lifetime Drift	E_{sens_drift}			± 1		%
Total Output Error Lifetime Drift	E_{tot_drift}			± 1		%

¹ Typical values with +/- are 3 sigma values

² Percentage of I_P , with $I_P = I_{PR(max)}$.

³ A single part will not have both the maximum/minimum sensitivity error and maximum/minimum offset voltage, as that would violate the maximum/minimum total output error specification. Also, 3 sigma distribution values are combined by taking the square root of the sum of the squares. See Application Information section.

HC70140CB3

unless otherwise specified

Characteristic	Symbol	Test Conditions	Min.	Typ. ¹	Max.	Unit
Nominal Performance						
Supply Voltage	V_{CC}		3	–	3.6	V
Current-Sensing Range	I_{PR}		-40	–	40	A
Sensitivity	Sens	$I_{PR(min)} < I_P < I_{PR(max)}$	–	33	–	mV/A
Zero-Current Output Voltage	$V_{IOUT(Q)}$	Bidirectional, $I_P = 0$ A	–	1.65	–	V
Accuracy Performance						
Total Output Error ²	E_{TOT}	$I_P = I_{PR(max)}$, $T_j = -40^\circ\text{C}$ to 150°C	-2	± 0.8	2	%
Total Output Error Components³ $E_{TOT} = E_{SENS} + 100 \times V_{OE} / (\text{Sens} \times I_P)$						
Sensitivity Error	E_{sens}	$I_P = I_{PR(max)}$, $T_j = -40^\circ\text{C}$ to 150°C	-1.5	± 0.6	1.5	%
Offset Voltage	V_{OE}	$I_P = 0$ A, $T_j = -40^\circ\text{C}$ to 150°C	-10	± 5	10	mV
Lifetime Drift Characteristics						
Sensitivity Error Lifetime Drift	E_{sens_drift}			± 1		%
Total Output Error Lifetime Drift	E_{tot_drift}			± 1		%

¹ Typical values with +/- are 3 sigma values

² Percentage of I_P , with $I_P = I_{PR(max)}$.

³ A single part will not have both the maximum/minimum sensitivity error and maximum/minimum offset voltage, as that would violate the maximum/minimum total output error specification. Also, 3 sigma distribution values are combined by taking the square root of the sum of the squares. See Application Information section.

HC70150AU5

unless otherwise specified

Characteristic	Symbol	Test Conditions	Min.	Typ. ¹	Max.	Unit
Nominal Performance						
Supply Voltage	V_{CC}		4.5	–	5.5	V
Current-Sensing Range	I_{PR}		0	–	50	A
Sensitivity	Sens	$ I_{PR(min)} < I < I_{PR(max)} , V_{CC} = 5V$	–	80	–	mV/A
Zero-Current Output Voltage	$V_{IOUT(Q)}$	Unidirectional, $I_P = 0 A, V_{CC} = 5V$	–	$V_{CC} \times 0.1$	–	V
Accuracy Performance						
Total Output Error ²	E_{TOT}	$I_P = I_{PR(max)}, T_j = -40^\circ C \text{ to } 150^\circ C$	–2	± 0.7	2	%
Total Output Error Components³ $E_{TOT} = E_{SENS} + 100 \times V_{OE} / (Sens \times I_P)$						
Sensitivity Error	E_{sens}	$I_P = I_{PR(max)}, T_j = -40^\circ C \text{ to } 150^\circ C$	–1.5	± 0.7	1.5	%
Offset Voltage	V_{OE}	$I_P = 0 A, T_j = -40^\circ C \text{ to } 150^\circ C$	–10	± 6	10	mV
Lifetime Drift Characteristics						
Sensitivity Error Lifetime Drift	E_{sens_drift}			± 1		%
Total Output Error Lifetime Drift	E_{tot_drift}			± 1		%

¹ Typical values with +/- are 3 sigma values

² Percentage of I_P , with $I_P = I_{PR(max)}$.

³ A single part will not have both the maximum/minimum sensitivity error and maximum/minimum offset voltage, as that would violate the maximum/minimum total output error specification. Also, 3 sigma distribution values are combined by taking the square root of the sum of the squares. See Application Information section.

HC70150AU3

unless otherwise specified

Characteristic	Symbol	Test Conditions	Min.	Typ. ¹	Max.	Unit
Nominal Performance						
Supply Voltage	V_{CC}		3	–	3.6	V
Current-Sensing Range	I_{PR}		0	–	50	A
Sensitivity	Sens	$ I_{PR(min)} < I < I_{PR(max)} $, $V_{CC} = 3.3V$	–	52	–	mV/A
Zero-Current Output Voltage	$V_{IOUT(Q)}$	Unidirectional, $I_P = 0 A$, $V_{CC} = 3.3V$	–	$V_{CC} \times 0.1$	–	V
Accuracy Performance						
Total Output Error ²	E_{TOT}	$I_P = I_{PR(max)}$, $T_j = -40^\circ C$ to $150^\circ C$	–2	± 0.7	2	%
Total Output Error Components³ $E_{TOT} = E_{SENS} + 100 \times V_{OE}/(Sens \times I_P)$						
Sensitivity Error	E_{sens}	$I_P = I_{PR(max)}$, $T_j = -40^\circ C$ to $150^\circ C$	–1.5	± 0.7	1.5	%
Offset Voltage	V_{OE}	$I_P = 0 A$, $T_j = -40^\circ C$ to $150^\circ C$	–10	± 6	10	mV
Lifetime Drift Characteristics						
Sensitivity Error Lifetime Drift	E_{sens_drift}			± 1		%
Total Output Error Lifetime Drift	E_{tot_drift}			± 1		%

¹ Typical values with +/- are 3 sigma values

² Percentage of I_P , with $I_P = I_{PR(max)}$.

³ A single part will not have both the maximum/minimum sensitivity error and maximum/minimum offset voltage, as that would violate the maximum/minimum total output error specification. Also, 3 sigma distribution values are combined by taking the square root of the sum of the squares. See Application Information section.

HC70150AB5

unless otherwise specified

Characteristic	Symbol	Test Conditions	Min.	Typ. ¹	Max.	Unit
Nominal Performance						
Supply Voltage	V_{CC}		4.5	–	5.5	V
Current-Sensing Range	I_{PR}		-50	–	50	A
Sensitivity	Sens	$ I_{PR(min)} < I < I_{PR(max)} , V_{CC} = 5V$	–	40	–	mV/A
Zero-Current Output Voltage	$V_{IOUT(Q)}$	Bidirectional, $I_P = 0 A, V_{CC} = 5V$	–	$V_{CC} \times 0.5$	–	V
Accuracy Performance						
Total Output Error ²	E_{TOT}	$I_P = I_{PR(max)}, T_j = -40^\circ C \text{ to } 150^\circ C$	-2	± 0.8	2	%
Total Output Error Components³ $E_{TOT} = E_{SENS} + 100 \times V_{OE} / (Sens \times I_P)$						
Sensitivity Error	E_{sens}	$I_P = I_{PR(max)}, T_j = -40^\circ C \text{ to } 150^\circ C$	-1.5	± 0.6	1.5	%
Offset Voltage	V_{OE}	$I_P = 0 A, T_j = -40^\circ C \text{ to } 150^\circ C$	-10	± 5	10	mV
Lifetime Drift Characteristics						
Sensitivity Error Lifetime Drift	E_{sens_drift}			± 1		%
Total Output Error Lifetime Drift	E_{tot_drift}			± 1		%

¹ Typical values with +/- are 3 sigma values

² Percentage of I_P , with $I_P = I_{PR(max)}$.

³ A single part will not have both the maximum/minimum sensitivity error and maximum/minimum offset voltage, as that would violate the maximum/minimum total output error specification. Also, 3 sigma distribution values are combined by taking the square root of the sum of the squares. See Application Information section.

HC70150AB3

unless otherwise specified

Characteristic	Symbol	Test Conditions	Min.	Typ. ¹	Max.	Unit
Nominal Performance						
Supply Voltage	V_{CC}		3	–	3.6	V
Current-Sensing Range	I_{PR}		-50	–	50	A
Sensitivity	Sens	$ I_{PR(min)} < I < I_{PR(max)} , V_{CC} = 3.3V$	–	26	–	mV/A
Zero-Current Output Voltage	$V_{IOUT(Q)}$	Bidirectional, $I_P = 0 A, V_{CC} = 3.3V$	–	$V_{CC} \times 0.5$	–	V
Accuracy Performance						
Total Output Error ²	E_{TOT}	$I_P = I_{PR(max)}, T_j = -40^\circ C \text{ to } 150^\circ C$	-2	± 0.8	2	%
Total Output Error Components³ $E_{TOT} = E_{SENS} + 100 \times V_{OE} / (Sens \times I_P)$						
Sensitivity Error	E_{sens}	$I_P = I_{PR(max)}, T_j = -40^\circ C \text{ to } 150^\circ C$	-1.5	± 0.6	1.5	%
Offset Voltage	V_{OE}	$I_P = 0 A, T_j = -40^\circ C \text{ to } 150^\circ C$	-10	± 5	10	mV
Lifetime Drift Characteristics						
Sensitivity Error Lifetime Drift	E_{sens_drift}			± 1		%
Total Output Error Lifetime Drift	E_{tot_drift}			± 1		%

¹ Typical values with +/- are 3 sigma values

² Percentage of I_P , with $I_P = I_{PR(max)}$.

³ A single part will not have both the maximum/minimum sensitivity error and maximum/minimum offset voltage, as that would violate the maximum/minimum total output error specification. Also, 3 sigma distribution values are combined by taking the square root of the sum of the squares. See Application Information section.

HC70150BU5

unless otherwise specified

Characteristic	Symbol	Test Conditions	Min.	Typ. ¹	Max.	Unit
Nominal Performance						
Supply Voltage	V_{CC}		4.5	–	5.5	V
Current-Sensing Range	I_{PR}		0	–	50	A
Sensitivity	Sens	$I_{PR(min)} < I_P < I_{PR(max)}$	–	80	–	mV/A
Zero-Current Output Voltage	$V_{IOUT(Q)}$	Unidirectional, $I_P = 0$ A	–	0.5	–	V
Accuracy Performance						
Total Output Error ²	E_{TOT}	$I_P = I_{PR(max)}$, $T_j = -40^\circ\text{C}$ to 150°C	–2	± 0.7	2	%
Total Output Error Components³ $E_{TOT} = E_{SENS} + 100 \times V_{OE}/(\text{Sens} \times I_P)$						
Sensitivity Error	E_{sens}	$I_P = I_{PR(max)}$, $T_j = -40^\circ\text{C}$ to 150°C	–1.5	± 0.7	1.5	%
Offset Voltage	V_{OE}	$I_P = 0$ A, $T_j = -40^\circ\text{C}$ to 150°C	–10	± 6	10	mV
Lifetime Drift Characteristics						
Sensitivity Error Lifetime Drift	E_{sens_drift}			± 1		%
Total Output Error Lifetime Drift	E_{tot_drift}			± 1		%

¹ Typical values with +/- are 3 sigma values

² Percentage of I_P , with $I_P = I_{PR(max)}$.

³ A single part will not have both the maximum/minimum sensitivity error and maximum/minimum offset voltage, as that would violate the maximum/minimum total output error specification. Also, 3 sigma distribution values are combined by taking the square root of the sum of the squares. See Application Information section.

HC70150BB5

unless otherwise specified

Characteristic	Symbol	Test Conditions	Min.	Typ. ¹	Max.	Unit
Nominal Performance						
Supply Voltage	V_{CC}		4.5	–	5.5	V
Current-Sensing Range	I_{PR}		-50	–	50	A
Sensitivity	Sens	$I_{PR(min)} < I_P < I_{PR(max)}$	–	40	–	mV/A
Zero-Current Output Voltage	$V_{IOUT(Q)}$	Bidirectional, $I_P = 0$ A	–	2.5	–	V
Accuracy Performance						
Total Output Error ²	E_{TOT}	$I_P = I_{PR(max)}$, $T_j = -40^\circ\text{C}$ to 150°C	-2	± 0.8	2	%
Total Output Error Components³ $E_{TOT} = E_{SENS} + 100 \times V_{OE} / (\text{Sens} \times I_P)$						
Sensitivity Error	E_{sens}	$I_P = I_{PR(max)}$, $T_j = -40^\circ\text{C}$ to 150°C	-1.5	± 0.6	1.5	%
Offset Voltage	V_{OE}	$I_P = 0$ A, $T_j = -40^\circ\text{C}$ to 150°C	-10	± 5	10	mV
Lifetime Drift Characteristics						
Sensitivity Error Lifetime Drift	E_{sens_drift}			± 1		%
Total Output Error Lifetime Drift	E_{tot_drift}			± 1		%

¹ Typical values with +/- are 3 sigma values

² Percentage of I_P , with $I_P = I_{PR(max)}$.

³ A single part will not have both the maximum/minimum sensitivity error and maximum/minimum offset voltage, as that would violate the maximum/minimum total output error specification. Also, 3 sigma distribution values are combined by taking the square root of the sum of the squares. See Application Information section.

HC70150CU5

unless otherwise specified

Characteristic	Symbol	Test Conditions	Min.	Typ. ¹	Max.	Unit
Nominal Performance						
Supply Voltage	V_{CC}		4.5	–	5.5	V
Current-Sensing Range	I_{PR}		0	–	50	A
Sensitivity	Sens	$I_{PR(min)} < I_P < I_{PR(max)}$	–	52	–	mV/A
Zero-Current Output Voltage	$V_{IOUT(Q)}$	Unidirectional, $I_P = 0$ A	–	0.33	–	V
Accuracy Performance						
Total Output Error ²	E_{TOT}	$I_P = I_{PR(max)}$, $T_j = -40^\circ\text{C}$ to 150°C	–2	± 0.7	2	%
Total Output Error Components³ $E_{TOT} = E_{SENS} + 100 \times V_{OE} / (\text{Sens} \times I_P)$						
Sensitivity Error	E_{sens}	$I_P = I_{PR(max)}$, $T_j = -40^\circ\text{C}$ to 150°C	–1.5	± 0.7	1.5	%
Offset Voltage	V_{OE}	$I_P = 0$ A, $T_j = -40^\circ\text{C}$ to 150°C	–10	± 6	10	mV
Lifetime Drift Characteristics						
Sensitivity Error Lifetime Drift	E_{sens_drift}			± 1		%
Total Output Error Lifetime Drift	E_{tot_drift}			± 1		%

¹ Typical values with +/- are 3 sigma values

² Percentage of I_P , with $I_P = I_{PR(max)}$.

³ A single part will not have both the maximum/minimum sensitivity error and maximum/minimum offset voltage, as that would violate the maximum/minimum total output error specification. Also, 3 sigma distribution values are combined by taking the square root of the sum of the squares. See Application Information section.

HC70150CU3

unless otherwise specified

Characteristic	Symbol	Test Conditions	Min.	Typ. ¹	Max.	Unit
Nominal Performance						
Supply Voltage	V_{CC}		3	–	3.6	V
Current-Sensing Range	I_{PR}		0	–	50	A
Sensitivity	Sens	$I_{PR(min)} < I_P < I_{PR(max)}$	–	52	–	mV/A
Zero-Current Output Voltage	$V_{IOUT(Q)}$	Unidirectional, $I_P = 0$ A	–	0.33	–	V
Accuracy Performance						
Total Output Error ²	E_{TOT}	$I_P = I_{PR(max)}$, $T_j = -40^\circ\text{C}$ to 150°C	–2	± 0.7	2	%
Total Output Error Components³ $E_{TOT} = E_{SENS} + 100 \times V_{OE} / (\text{Sens} \times I_P)$						
Sensitivity Error	E_{sens}	$I_P = I_{PR(max)}$, $T_j = -40^\circ\text{C}$ to 150°C	–1.5	± 0.7	1.5	%
Offset Voltage	V_{OE}	$I_P = 0$ A, $T_j = -40^\circ\text{C}$ to 150°C	–10	± 6	10	mV
Lifetime Drift Characteristics						
Sensitivity Error Lifetime Drift	E_{sens_drift}			± 1		%
Total Output Error Lifetime Drift	E_{tot_drift}			± 1		%

¹ Typical values with +/- are 3 sigma values

² Percentage of I_P , with $I_P = I_{PR(max)}$.

³ A single part will not have both the maximum/minimum sensitivity error and maximum/minimum offset voltage, as that would violate the maximum/minimum total output error specification. Also, 3 sigma distribution values are combined by taking the square root of the sum of the squares. See Application Information section.

HC70150CB5

unless otherwise specified

Characteristic	Symbol	Test Conditions	Min.	Typ. ¹	Max.	Unit
Nominal Performance						
Supply Voltage	V _{CC}		4.5	–	5.5	V
Current-Sensing Range	I _{PR}		-50	–	50	A
Sensitivity	Sens	$I_{PR(min)} < I_P < I_{PR(max)}$	–	26	–	mV/A
Zero-Current Output Voltage	V _{IOUT(Q)}	Bidirectional, I _P = 0 A	–	1.65	–	V
Accuracy Performance						
Total Output Error ²	E _{TOT}	I _P = I _{PR(max)} , T _j = -40°C to 150°C	-2	±0.8	2	%
Total Output Error Components³ E_{TOT} = E_{SENS} + 100 × V_{OE} / (Sens × I_P)						
Sensitivity Error	E _{sens}	I _P = I _{PR(max)} , T _j = -40°C to 150°C	-1.5	±0.6	1.5	%
Offset Voltage	V _{OE}	I _P = 0 A, T _j = -40°C to 150°C	-10	±5	10	mV
Lifetime Drift Characteristics						
Sensitivity Error Lifetime Drift	E _{sens_drift}			±1		%
Total Output Error Lifetime Drift	E _{tot_drift}			±1		%

¹ Typical values with +/- are 3 sigma values

² Percentage of I_P, with I_P = I_{PR(max)}.

³ A single part will not have both the maximum/minimum sensitivity error and maximum/minimum offset voltage, as that would violate the maximum/minimum total output error specification. Also, 3 sigma distribution values are combined by taking the square root of the sum of the squares. See Application Information section.

HC70150CB3

unless otherwise specified

Characteristic	Symbol	Test Conditions	Min.	Typ. ¹	Max.	Unit
Nominal Performance						
Supply Voltage	V_{CC}		3	–	3.6	V
Current-Sensing Range	I_{PR}		-50	–	50	A
Sensitivity	Sens	$I_{PR(min)} < I_P < I_{PR(max)}$	–	26	–	mV/A
Zero-Current Output Voltage	$V_{IOUT(Q)}$	Bidirectional, $I_P = 0$ A	–	1.65	–	V
Accuracy Performance						
Total Output Error ²	E_{TOT}	$I_P = I_{PR(max)}$, $T_j = -40^\circ\text{C}$ to 150°C	-2	± 0.8	2	%
Total Output Error Components³ $E_{TOT} = E_{SENS} + 100 \times V_{OE}/(\text{Sens} \times I_P)$						
Sensitivity Error	E_{sens}	$I_P = I_{PR(max)}$, $T_j = -40^\circ\text{C}$ to 150°C	-1.5	± 0.6	1.5	%
Offset Voltage	V_{OE}	$I_P = 0$ A, $T_j = -40^\circ\text{C}$ to 150°C	-10	± 5	10	mV
Lifetime Drift Characteristics						
Sensitivity Error Lifetime Drift	E_{sens_drift}			± 1		%
Total Output Error Lifetime Drift	E_{tot_drift}			± 1		%

¹ Typical values with +/- are 3 sigma values

² Percentage of I_P , with $I_P = I_{PR(max)}$.

³ A single part will not have both the maximum/minimum sensitivity error and maximum/minimum offset voltage, as that would violate the maximum/minimum total output error specification. Also, 3 sigma distribution values are combined by taking the square root of the sum of the squares. See Application Information section.

6 Application Information

6.1 Estimating Total Error vs. Sensed Current

The Performance Characteristics tables give distribution ($\pm 3\sigma$) values for Total Error at $I_{PR(max)}$; however, one often wants to know what error to expect at a particular current. This can be estimated by using the distribution data for the components of Total Error, Sensitivity Error, and Offset Voltage. The ± 3 sigma value for Total Error (E_{TOT}) as a function of the sensed current (I_P) is estimated as:

$$E_{TOT}(I_P) = \sqrt{E_{SENS}^2 + \left(\frac{100 \times V_{OE}}{Sens \times I_P}\right)^2}$$

Here, E_{SENS} and V_{OE} are the ± 3 sigma values for those error terms. If there is an average sensitivity error or average offset voltage, then the average Total Error is estimated as:

$$E_{TOTAVG}(I_P) = E_{SENSAVG} + \frac{100 \times V_{OEAVG}}{Sens \times I_P}$$

The resulting total error will be a sum of E_{TOT} and E_{TOT_AVG} . Using these equations and the 3 sigma distributions for Sensitivity Error and Offset Voltage, the Total Error versus sensed current (I_P) is below for the HC70120AB. As expected, as one goes towards zero current, the error in percent goes towards infinity due to division by zero.

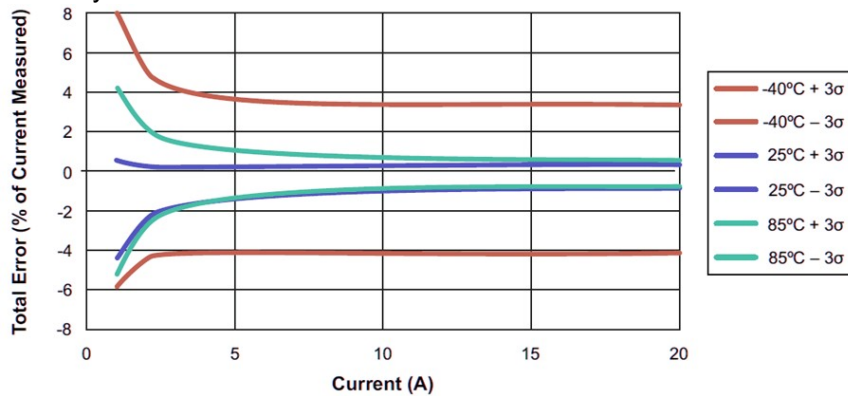

Figure 1: Predicted Total Error as a Function of the Sensed Current for the HC70120AB

6.2 Definitions of accuracy characteristics

Sensitivity (Sens). The change in sensor IC output in response to a 1 A change through the primary conductor. The sensitivity is the product of the magnetic circuit sensitivity (G/A) (1 G = 0.1 mT) and the linear IC amplifier gain (mV/G). The linear IC amplifier gain is programmed at the factory to optimize the sensitivity (mV/A) for the full-scale current of the device.

Nonlinearity (E_{LIN}). The nonlinearity is a measure of how linear the output of the sensor IC is over the full current measurement range. The nonlinearity is calculated as:

$$E_{LIN} = \left\{ 1 - \left[\frac{V_{IOUT}(I_{PR(max)}) - V_{IOUT(Q)}}{2 \times V_{IOUT}(I_{PR(max)}/2) - V_{IOUT(Q)}} \right] \right\} \times 100(\%)$$

where $V_{IOUT}(I_{PR(max)})$ is the output of the sensor IC with the maximum measurement current flowing through it and $V_{IOUT}(I_{PR(max)}/2)$ is the output of the sensor IC with half of the maximum measurement current flowing through it.

Zero-Current Output Voltage ($V_{IOUT(Q)}$). The output of the sensor when the primary current is zero. For a unipolar supply voltage, it nominally remains at $0.5 \times V_{CC}$ for a bidirectional device and $0.1 \times V_{CC}$ for a unidirectional device. For example, in the case of a bidirectional output device, $V_{CC} = 5\text{ V}$ translates into $V_{IOUT(Q)} = 2.5\text{ V}$. Variation in $V_{IOUT(Q)}$ can be attributed to the resolution of the linear IC quiescent voltage trim and thermal drift.

Offset Voltage (V_{OE}). The deviation of the device output from its ideal quiescent value of $0.5 \times V_{CC}$ (bidirectional) or $0.1 \times V_{CC}$ (unidirectional) due to nonmagnetic causes. To convert this voltage to amperes, divide by the device sensitivity, Sens.

Total Output Error (E_{TOT}). The difference between the current measurement from the sensor IC and the actual current (I_P), relative to the actual current. This is equivalent to the difference between the ideal output voltage and the actual output voltage, divided by the ideal sensitivity, relative to the current flowing through the primary conduction path:

$$E_{TOT}(I_P) = V \frac{I_{OUT_ideal}(I_P) - V_{IOUT}(I_P)}{Sens_{ideal}(I_P) \times I_P} \times 100(\%)$$

The Total Output Error incorporates all sources of error and is a function of I_P . At relatively high currents, E_{TOT} will be mostly due to sensitivity error, and at relatively low currents, E_{TOT} will be mostly due to Offset Voltage (V_{OE}). In fact, at $I_P = 0$, E_{TOT} approaches infinity due to the offset. This is illustrated in Figures 2 and 3. Figure 2 shows a distribution of output voltages versus I_P at 25°C and

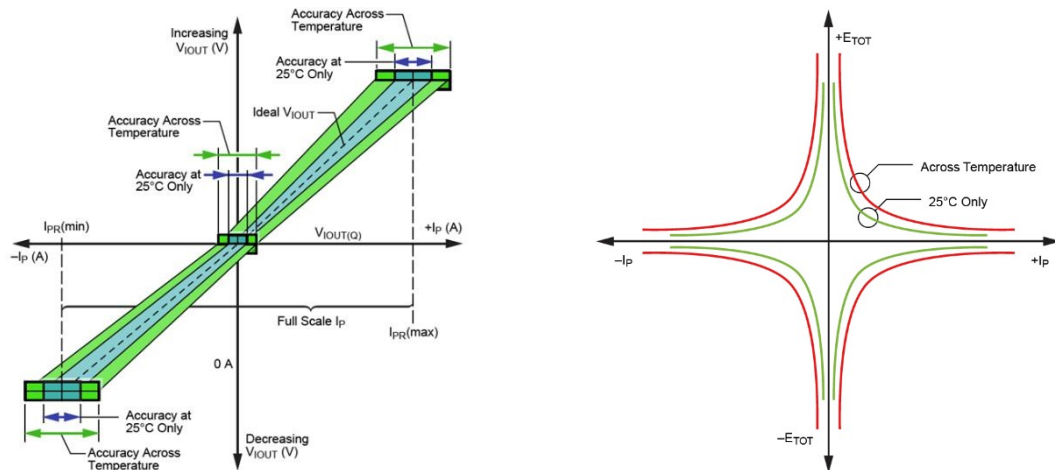

across temperature. Figure 3 shows the corresponding E_{TOT} versus I_P .

Figure 2: Output Voltage versus Sensed Current

Figure 3: Total Output Error versus Sensed Current

Sensitivity Ratiometry Coefficient (SENS_RAT_COEF). The coefficient defines how the sensitivity scales with V_{CC} . The ideal coefficient is 1, meaning the sensitivity scales proportionally with V_{CC} . A 10% increase in V_{CC} results in a 10% increase in sensitivity. A coefficient of 1.1 means that the

sensitivity increases by 10% more than the ideal proportionality case. This means that a 10% increase in V_{CC} results in an 11% increase in sensitivity. This relationship is described by the following equation:

$$Sens(V_{CC}) = Sens(5V) \left[1 + \frac{(V_{CC} - 5V) \times SENS_RAT_COEF}{5V} \right]$$

can be rearranged to define the sensitivity ratiometry coefficient as:

$$SENS_{RATCOEF} = \left[\frac{Sens(V_{CC})}{Sens(5V)} - 1 \right] \times \frac{5V}{V_{CC} - 5V}$$

Zero-Current Output Ratiometry Coefficient (QVO_RAT_COEF). The coefficient defines how the zero-current output voltage scales with V_{CC} . The ideal coefficient is 1, meaning the output voltage scales proportionally with V_{CC} , always being equal to $V_{CC}/2$. A coefficient of 1.1 means that the zero-current output voltage increases by 10% more than the ideal proportionality case. This means that a 10% increase in V_{CC} results in an 11% increase in the zero-current output voltage. This relationship is described by the following equation:

$$VIOUTQ(V_{CC}) = VIOUTQ(5V) \left[1 + \frac{(V_{CC} - 5V) \times QVO_RAT_COEF}{5V} \right]$$

This can be rearranged to define the zero-current output ratiometry coefficient as:

$$QVO_RAT_COEF = \left[\frac{VIOUTQ(V_{CC})}{VIOUTQ(5V)} - 1 \right] \times \frac{5V}{V_{CC} - 5V}$$

6.3 Definitions of dynamic response characteristics

Power-On Time (t_{PO}). When the supply is ramped to its operating voltage, the device requires a finite time to power its internal components before responding to an input magnetic field. Power-On Time, t_{PO} , is defined as the time it takes for the output voltage to settle within $\pm 10\%$ of its steady-state value under an applied magnetic field, after the power supply has reached its minimum specified operating voltage, $V_{CC(min)}$, as shown in the chart at right.

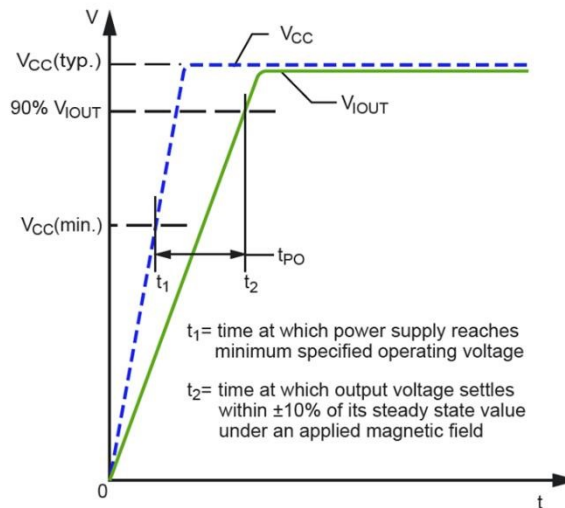

Figure 4: Power-On Time

Rise Time (t_r). The time interval between a) when the sensor IC reaches 10% of its full-scale value, and b) when it reaches 90% of its full-scale value. The rise time to a step response is used to derive the bandwidth of the current sensor IC, in which $f(-3\text{ dB}) = 0.35 / t_r$. Both t_r and $t_{RESPONSE}$ are detrimentally affected by eddy-current losses observed in the conductive IC ground plane.

Propagation Delay (t_{pd}). The propagation delay is measured as the time interval a) when the primary current signal reaches 20% of its final value, and b) when the device reaches 20% of its output corresponding to the applied current.

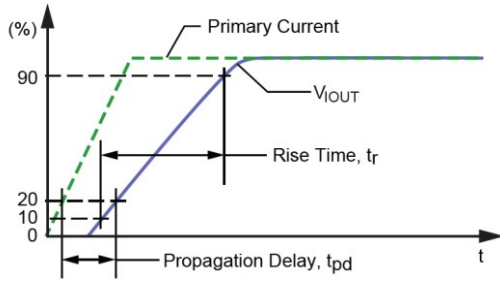

Figure 5: Rise Time and Propagation Delay

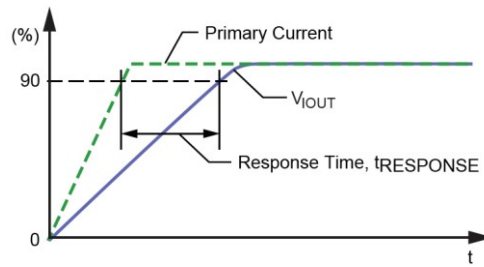

Figure 6: Response Time

Response Time ($t_{RESPONSE}$). The time interval between a) when the primary current signal reaches 90% of its final value, and b) when the device reaches 90% of its output corresponding to the applied current.

7 Package Information:

For Reference Only – Not for Tooling Use

(Reference MS-012AA)

Dimensions in millimeters – NOT TO SCALE

Dimensions exclusive of mold flash, gate burrs, and dambar protrusions

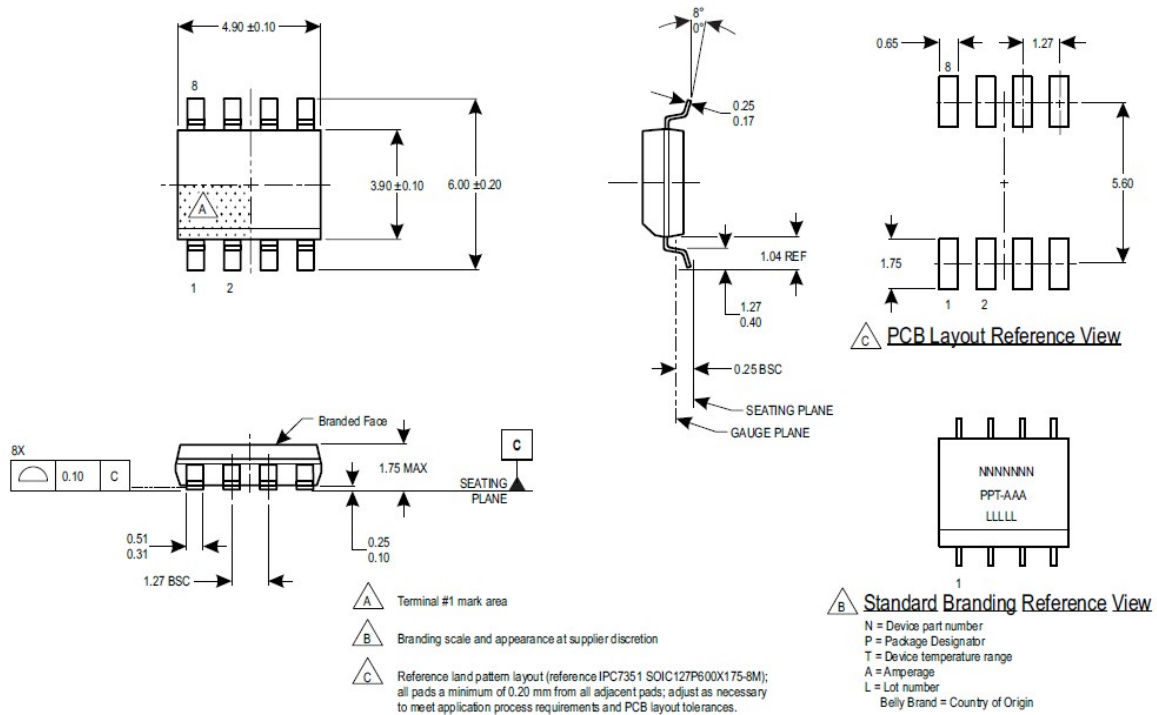

Figure 7: Package LC, 8-pin SOIC