

## Wireless Power Transmitter with PD and 15W Applications

### 1 Description

The CV90335 is a wireless power transmitter controller that integrates all required functions for the WPC “Qi” compliant wireless power transmitter design, which supports various adapters such as PD2.0, PD3.0, QC2.0, QC3.0, AFC and so on. Compliance with the latest WPC V1.3 standard, support MP-A11 coil, support customer coil customized solution, support BPP 5W, Apple 7.5W, Samsung 10W, EPP 15W charging.

The CV90335 has Integrated over voltage protection, over current protection, over temperature protection and other functions, and supports FOD detection.

The CV90335 is a QFN40 package, and integrates full bridge drive circuit and voltage & current communication decoding function module, which can significantly reduce PCB size and BOM cost.

### 2 Typical Applications

- ☆ BPP and EPP wireless charging pads
- ☆ Android fast charging pads
- ☆ Tablets
- ☆ Up to 7.5 W charging for iPhones

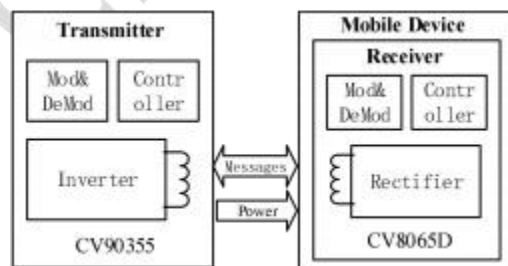

### 3 Features

- WPC 1.3.3 compatible
- 20kB Multiple-time programmable (MTP) non-volatile memory for expanded feature
- Power transfer up to 15W
- Support 2 equipment wireless charging at the same time
- Integrated drivers for external power MOSFETs
- Integrated voltage and current sense amplifier
- Real-time foreign object detection (FOD)
- Over-current and over-temperature protection
- Programming the LED instructions required by the customer
- Supports I2C interface
- -40 to +85°C ambient operating temperature range

### 4 Product Information

Orderable Part Number	Package Type	Package Size
CV90355	QFN40	5.00 * 5.00 * 0.75 mm

## 1 Pin Assignments

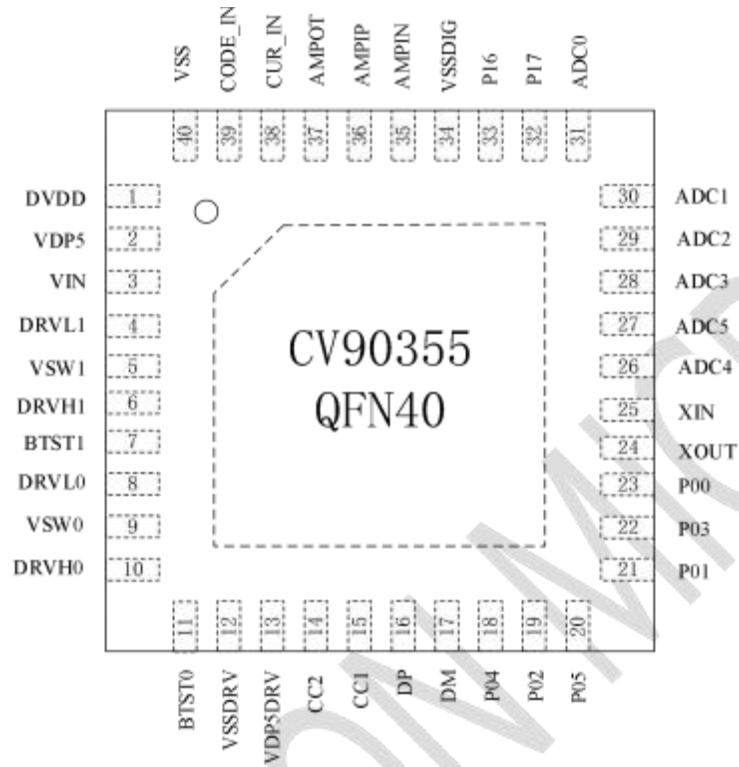

### 1.1 Pin Assignments

Pins	Name	Description
1	DVDD	Regulated 1.8V output used for internal device biasing. Connect a 1 $\mu$ F capacitor from this pin to ground.
2	VDP5	5V power output. Connect a 1 $\mu$ F capacitor from this pin to ground
3	VIN	power supply
4	DRVL1	MOSFET Half-Bridge Driver 1 Low-Side output
5	VSW1	MOSFET Half-Bridge Driver 1 High-side source connection
6	DRVH1	MOSFET Half-Bridge Driver 1 High-Side output
7	BTST1	MOSFET Half-Bridge Driver 1 High-side bootstrap supply
8	DRVL0	MOSFET Half-Bridge Driver 0 Low-Side output
9	VSW0	MOSFET Half-Bridge Driver 0 High-side source connection
10	DRVH0	MOSFET Half-Bridge Driver 0 High-Side output
11	BTST0	MOSFET Half-Bridge Driver 0 High-side bootstrap supply
12	VSSDRV	Gate drive GND
13	VDP5DRV	Grid driver power supply, 5V

Pins	Name	Description
14	CC2	Type-C CC2 detection pin
15	CC1	Type-C CC1 detection pin
16	DP	USB D+ interface
17	DM	USB D- interface
18	P04	General-purpose digital I/O pin
19	P02	General-purpose digital I/O pin Serial port 0 transmitter pin
20	P05	General-purpose digital I/O pin
21	P01	General-purpose digital I/O pin Emulation port data pin
22	P03	General-purpose digital I/O pin Serial port 0 receiving pin
23	P00	General-purpose digital I/O pin Emulation port clock pin
24	XOUT	External crystal output pin
25	XIN	External crystal input pin
26	ADC4	ADC input channel 4
27	ADC5	ADC input channel 5
28	ADC3	ADC input channel 3
29	ADC2	ADC input channel 2
30	ADC1	ADC input channel 1
31	ADC0	ADC input channel 0
32	P17	General-purpose digital I/O pin I2C SDA ADC input channel
33	P16	General-purpose digital I/O pin I2C SCL ADC input channel
34	VSSDIG	GND
35	AMPIN	Op-amp nagtive input terminal
36	AMPIP	Op-amp postive input terminal
37	AMOUT	Op-amp output terminal
38	CUR_IN	Current sensing demodulation input
39	CODE_IN	Voltage sensing demodulation input
40	VSS	GND

## 2 Absolute Maximum Ratings

Parameter	Symbol/Pins	Minimum	Maximum	Units
Voltage range	VSW0 , VSW1	-0.3	28	V
	BTST0 , BTST1	-0.3	28	V
	DRV L0 , DRV L1	-0.3	6	V
	DRV H0 , DRV H1	-0.3	28	V
	CC1, CC2	-0.3	28	V
	DP,DM	-0.3	20	V
	DVDD	-0.3	2	V
	VSS , VSSDRV , VSSDIG	-0.3	0.3	V
	Others pin	-0.3	6	V
Junction temperature	T <sub>J</sub>		125	°C
Storage temperature	T <sub>stg</sub>	-40	150	°C
Thermal resistance (junction temperature to environment)	θ <sub>JA</sub>		47	°C/W
Human Body Model(ESD)	ESD	-2000	2000	V

## 3 Recommended Operating Conditions

Parameter	Symbol/Pins	Minimum	Typical	Maximum	Units
Supply Voltage	V <sub>IN</sub>	3		21	V
Input voltage	VDP5, VDP5 DRV		5	5.5	V
	DVDD	1.62	1.8	1.98	V
I/O voltage	CC1, CC2	1.0	1.1	1.2	V
	DP,DM	0	3.3		
	AMPIN, AMPIP, AMP OT	0	5	5.5	V
	P00 , P01, P03,P16,P17	0	5	5.5	V
	ADC0 – ADC5, CUR_IN, CODE_IN	0	5	5.5	V
	VDP5, VDP5 DRV, XI N, XOUT	0	5	5.5	V
	Operating temperature	T <sub>A</sub>	-40		85

## 4 Functional Description

CV90355 is a highly integrated wireless charging solution chip that supports multiple adapters such as PD2.0, PD3.0, QC2.0, QC3.0, AFC, etc.

### 4.1 GPIO Application

CV90355 has 2 groups of GPIOs, P0[5:0], P1[7:6]. P16 and P17 are analog digital hybrid pads that can be configured as GPIO or ADC input.

### 4.2 User- defined

CV90355 can be configured with GPIO to inform the end user of the charging status of a variety of options:

- Use GPIO and built-in timer to control the buzzer. When the power transmission circuit is connected, the buzzer will make a sound;
- Control the LED, telling the user that different events define other states;
- Support custom lamp display

### 4.3 Receiver type detection (WPC or High-Speed-Charger Modes)

The CV90355 supports receivers conforming to WPC or high-speed charging modes. Detect the mode of operation of the receiver type by sending the WPC protocol to connect to the WPC receiver. Through the handshake signal, it detects the load equipment such as BPP/EPP, and then sends the current and voltage signal adapted to it. CV90355 can output the corresponding load power according to the input power voltage of the transmitter (5V input, 5W output; 9V input, 5W/7.5W/10W output; 12 Input, 5W/7.5W/10W/15W).

### 4.4 Over-voltage and over-current protection

The CV90355 supports receivers conforming to WPC or high-speed charging modes. Detect the mode of operation of the receiver type by sending the WPC protocol to connect to the WPC receiver. Through the handshake signal, it detects the load equipment such as BPP/EPP, and then sends the current and voltage signal adapted to it. CV90355 can output the corresponding load power according to the input power voltage of the transmitter (5V input, 5W output; 9V input, 5W/7.5W/10W output; 12 Input, 5W/7.5W/10W/15W).

#### 4.5 Temperature protection

The CV90355 integrates temperature overload protection to prevent damage due to overheating in fault conditions. If the chip temperature exceeds the thermal shutdown threshold, the circuit will shut down or the device will reset. To allow the maximum possible load current and prevent thermal overload, all available pins must be soldered to the PCB to ensure that the heat generated by the CV90355 solution is radiated to the PCB. GND pins (especially the E-Pad) and external bridge FETs should be solder to the PCB ground or power layer, connected to all layers of the PCB through multiple through holes to improve thermal performance.

For the QFN package, the exposed pads (hot pads) are soldered onto the PCB and multiple through holes are evenly distributed under the package and led out from the bottom of the PCB.

#### 4.6 Wireless charging system description

A wireless power charging system has a base station with one or more transmitters that transmit power to a receiver in a mobile device through a strongly coupled inductor. The WPC transmitter can be of free position or magnetic boot type. The free-positioning type of transmitter has coils that provide the end user with limited spatial freedom to align the receiver with the transmitter.

The power transmitted to the mobile device is controlled by a receiver. The receiver sends communication packets to the sender to increase power, reduce power, or maintain power levels. Communication is entirely digital, with communications 1 and 0 located on a power link between the two coils.

One feature of wireless charging systems is that when they're not charging the mobile device, the sender is in a very low-power sleep mode. The sender maintains this low-power mode and pings periodically until the sender detects the presence of a receiver. Only after a valid receiver is detected does the transmitter enter the negotiation phase of the operation and begin power transmission.

## 5 Typical application schematics

Please refer to page 8 of this article for a typical schematic.

## 6 Product information

The package outline is shown on the page 9.

Orderable Part Number	Package	MSL Rating	Shipping Packaging	Minimum packaging quantity
CV90355	QFN40 (5.00 * 5.00 * 0.75 mm)	MSL3	Reel	3000 PCS

# CV90355

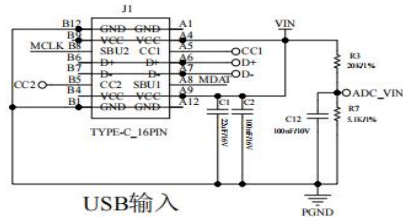

USB输入

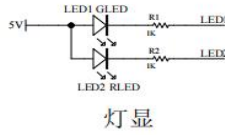

灯显

- 1, SMD贴片NTC靠近MOS附近摆放
- 2, 焊线NTC, 置于线圈中心位置

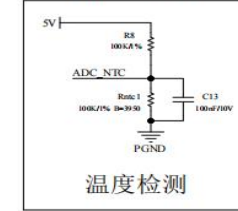

温度检测

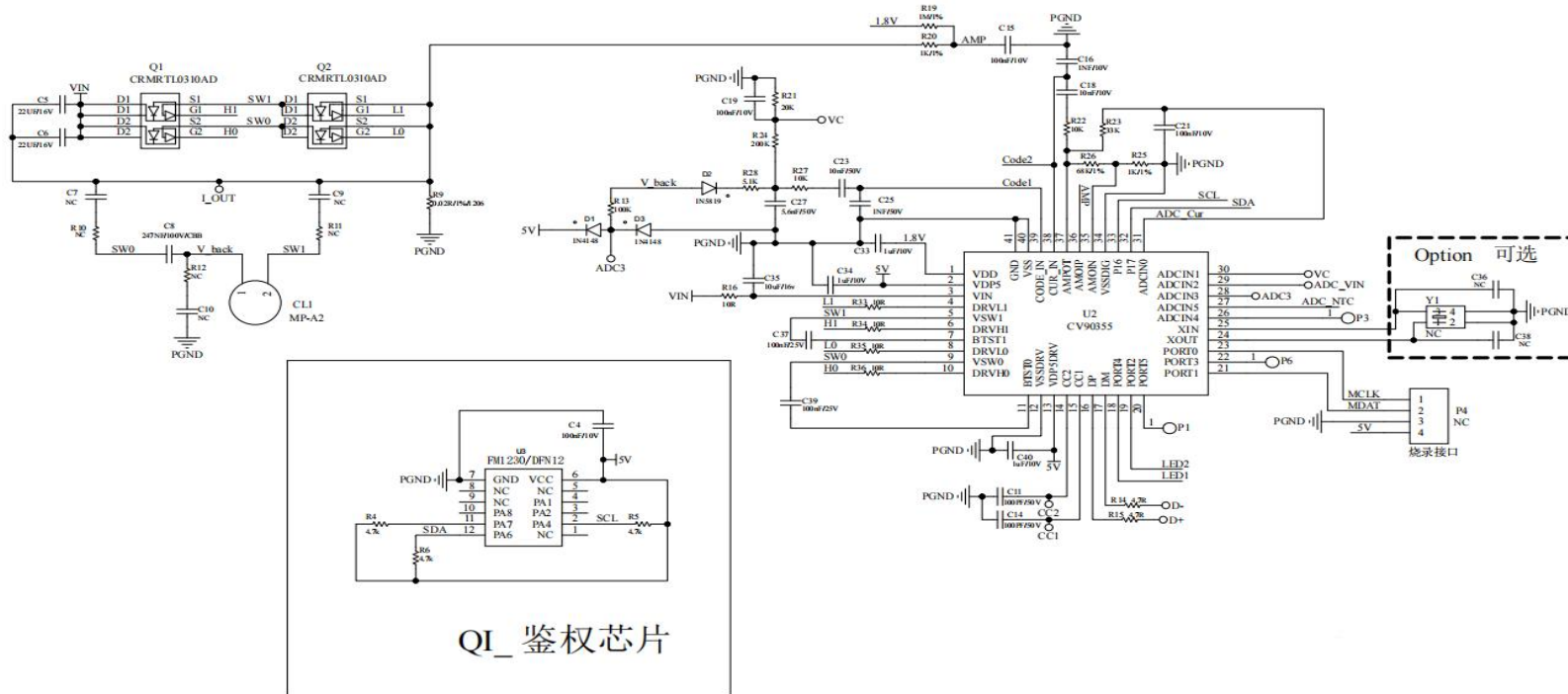

QI\_鉴权芯片

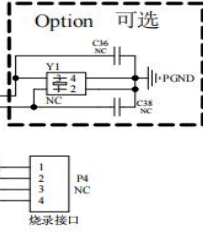

烧录接口

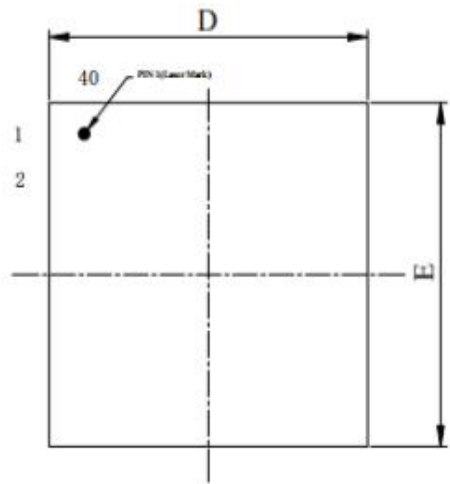

TOP VIEW

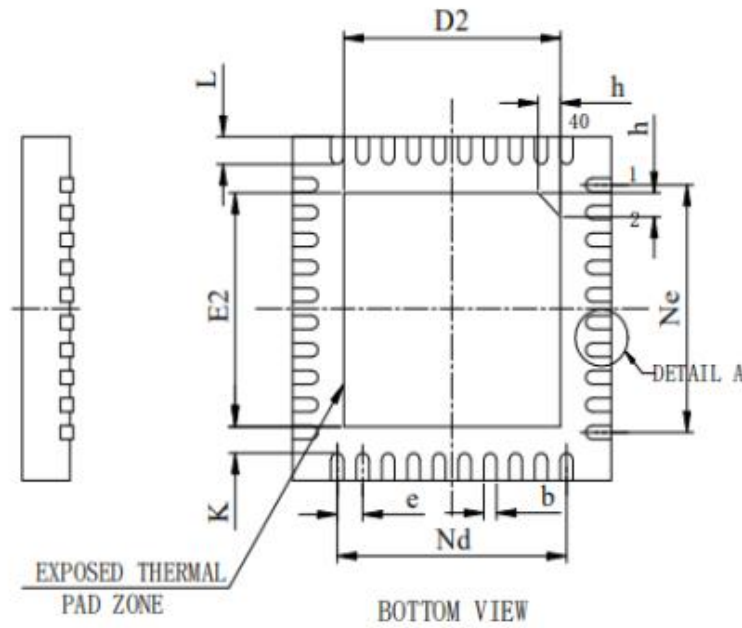

BOTTOM VIEW

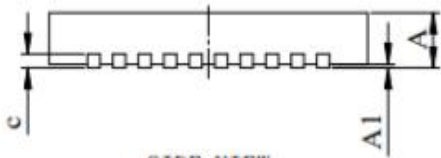

SIDE VIEW



OptionA

SYMBOL	MILLIMETER		
	MIN	NOM	MAX
A	0.70	0.75	0.80
A1	0	0.02	0.05
b	0.15	0.25	0.25
c	0.10	0.20	0.3
D	4.90	5.00	5.10
D2	3.4REF		
e	0.40BSC		
Ne	3.60BSC		
Nd	3.60BSC		
E	4.90	5.00	5.10
E2	3.4REF		
L	0.35	0.40	0.45
K	0.20	--	--
h	0.35REF		

SHENZHEN CHIPSVISION MICROELECTRONICS CO., LTD

Tel: +86-0755-86547479

MP: +86-189 2679 5424

WeChat: 189 2679 5424

Email: sales@chipsvision.com.cn

Website: www.chipsvision.com.cn