

**Description**

**ELV607R0ND N-channel Enhancement Mode Power MOSFET**

**Features**

- 60V, 80A
- $R_{DS(ON)} < 8.5m\Omega @ V_{GS} = 10V$
- Advanced Trench Technology
- Provide Excellent  $R_{DS(ON)}$  and Low Gate Charge
- Lead free product is acquired

**Application**

- Load Switch
- PWM Application
- Power management



TO-252 top view



Marking and pin Assignment

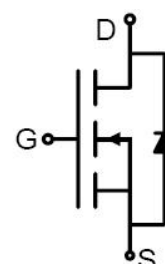

Schematic Diagram

**Package Marking and Ordering Information**

Device Marking	Device	OUTLINE	Device Package	TUBE (PCS)	Inner BOX (PCS)	Per Carton (PCS)
ELV607R0ND	ELV607R0ND	TAPING	TO-252-4R	13inch	2500	25000

**Absolute Maximum Ratings** ( $T_c=25^\circ C$  unless otherwise specified)

Symbol	Parameter	Max.	Units
$V_{DSS}$	Drain-Source Voltage	68	V
$V_{GSS}$	Gate-Source Voltage	$\pm 20$	V
$I_D$	Continuous Drain Current	$T_c = 25^\circ C$	80
		$T_c = 100^\circ C$	57
$I_{DM}$	Pulsed Drain Current <sup>note1</sup>	320	A
$E_{AS}$	Single Pulsed Avalanche Energy <sup>note2</sup>	389	mJ
$P_D$	Power Dissipation $T_c = 25^\circ C$	107	W
$R_{\theta JC}$	Thermal Resistance, Junction to Case	1.4	$^\circ C/W$
$T_J, T_{STG}$	Operating and Storage Temperature Range	-55 to +175	$^\circ C$

**Electrical Characteristics** ( $T_J=25^{\circ}\text{C}$  unless otherwise specified)

Symbol	Parameter	Test Condition	Min.	Typ.	Max.	Units
<b>Off Characteristic</b>						
$V_{(BR)DSS}$	Drain-Source Breakdown Voltage	$V_{GS}=0V, I_D=250\mu A$	60	-	-	V
$I_{DSS}$	Zero Gate Voltage Drain Current	$V_{DS}=60V, V_{GS}=0V,$	-	-	1.0	$\mu A$
$I_{GSS}$	Gate to Body Leakage Current	$V_{DS}=0V, V_{GS}=\pm 20V$	-	-	$\pm 100$	nA
<b>On Characteristics</b>						
$V_{GS(th)}$	Gate Threshold Voltage	$V_{DS}=V_{GS}, I_D=250\mu A$	2	-	4	V
$R_{DS(on)}$	Static Drain-Source on-Resistance <small>note3</small>	$V_{GS}=10V, I_D=20A$	-	7	8.5	m $\Omega$
<b>Dynamic Characteristics</b>						
$C_{iss}$	Input Capacitance	$V_{DS}=30V, V_{GS}=0V,$ $f=1.0MHz$	-	4244	-	pF
$C_{oss}$	Output Capacitance		-	245	-	pF
$C_{rss}$	Reverse Transfer Capacitance		-	193	-	pF
$Q_g$	Total Gate Charge	$V_{DS}=48V, I_D=20A,$ $V_{GS}=10V$	-	81	-	nC
$Q_{gs}$	Gate-Source Charge		-	23	-	nC
$Q_{gd}$	Gate-Drain("Miller") Charge		-	22	-	nC
<b>Switching Characteristics</b>						
$t_{d(on)}$	Turn-on Delay Time	$V_{DS}=30V, I_D=30A,$ $R_{GEN}=3\Omega, V_{GS}=10V$	-	19	-	ns
$t_r$	Turn-on Rise Time		-	47	-	ns
$t_{d(off)}$	Turn-off Delay Time		-	78	-	ns
$t_f$	Turn-off Fall Time		-	24	-	ns
<b>Drain-Source Diode Characteristics and Maximum Ratings</b>						
$I_S$	Maximum Continuous Drain to Source Diode Forward Current		-	-	60	A
$I_{SM}$	Maximum Pulsed Drain to Source Diode Forward Current		-	-	240	A
$V_{SD}$	Drain to Source Diode Forward Voltage	$V_{GS}=0V, I_S=20A$	-	-	1.4	V
$t_{rr}$	Body Diode Reverse Recovery Time	$T_J=25^{\circ}\text{C}$ $I_F=20A, di/dt=100A/\mu s$	-	27	-	ns
$Q_{rr}$	Body Diode Reverse Recovery Charge		-	0.03	-	nC

Notes:1. Repetitive Rating: Pulse Width Limited by Maximum Junction Temperature

2. EAS condition:  $T_J=25^{\circ}\text{C}, V_{DD}=50V, V_G=10V, R_G=10\Omega, L=0.5mH$

3. Pulse Test: Pulse Width $\leq 300\mu s$ , Duty Cycle $\leq 2\%$

Typical Performance Characteristics

图 1. 输出特性



图 2. 传输特性



图 3. 导通电阻 vs. 漏电流

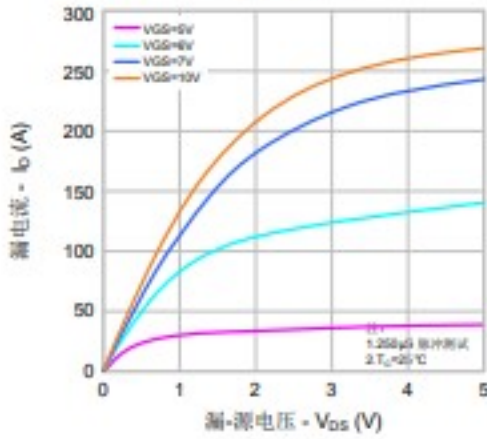

图 4. 体二极管正向压降 vs. 源电流和温度

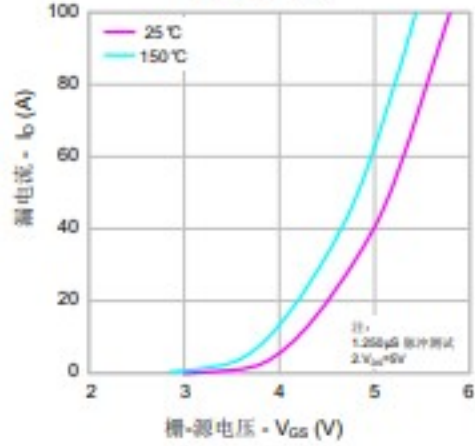

图 5. 电容特性

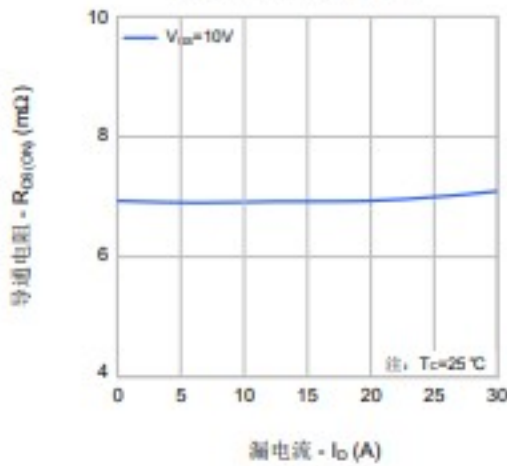

图 6. 栅极电荷特性

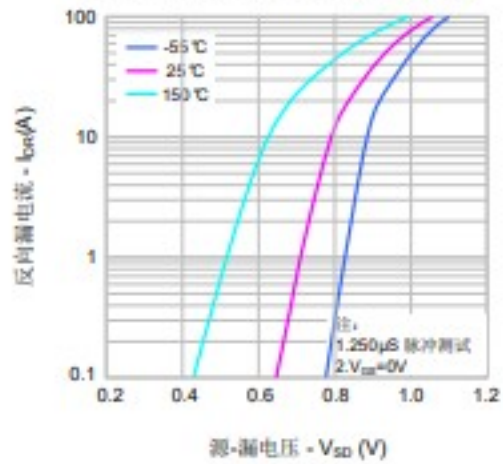

图 7. 击穿电压 vs. 温度特性

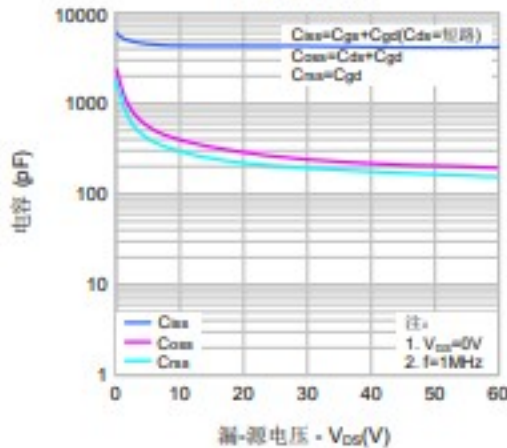

图 8. 导通电阻 vs. 温度特性

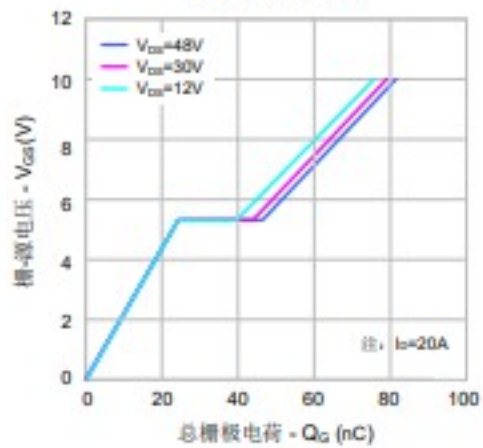

图 9-1. 最大安全工作区域(SVT068R5ND)

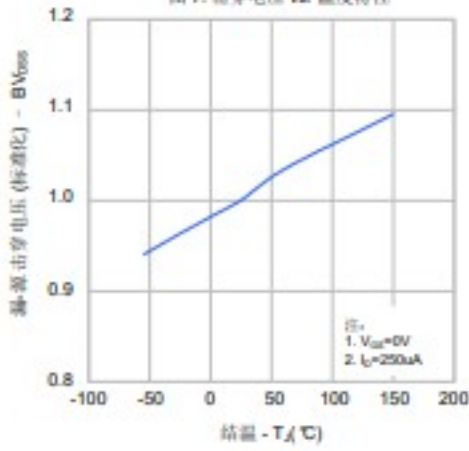

图 9-2. 最大安全工作区域(SVT068R5NT)

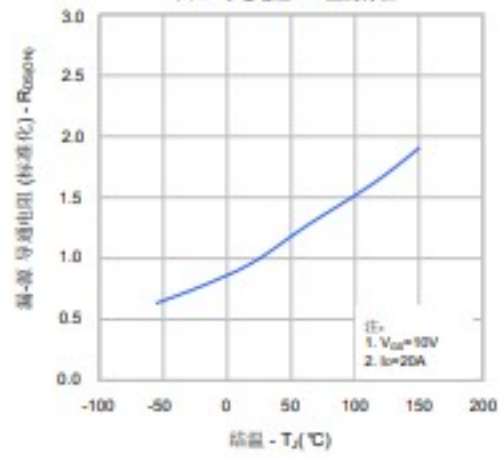

Test Circuit

栅极电荷量测试电路及波形图

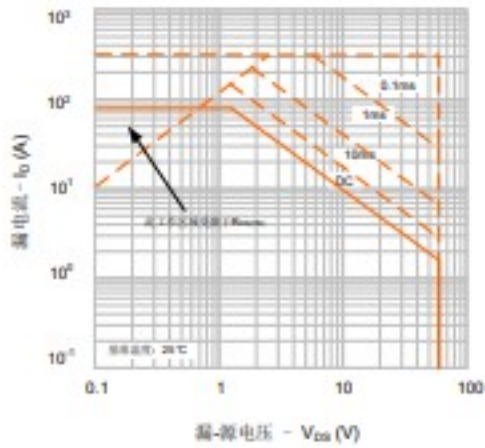
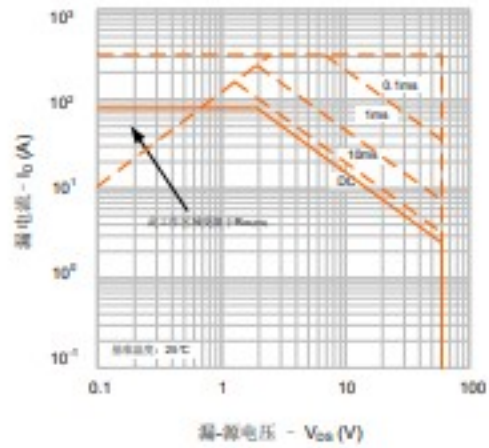
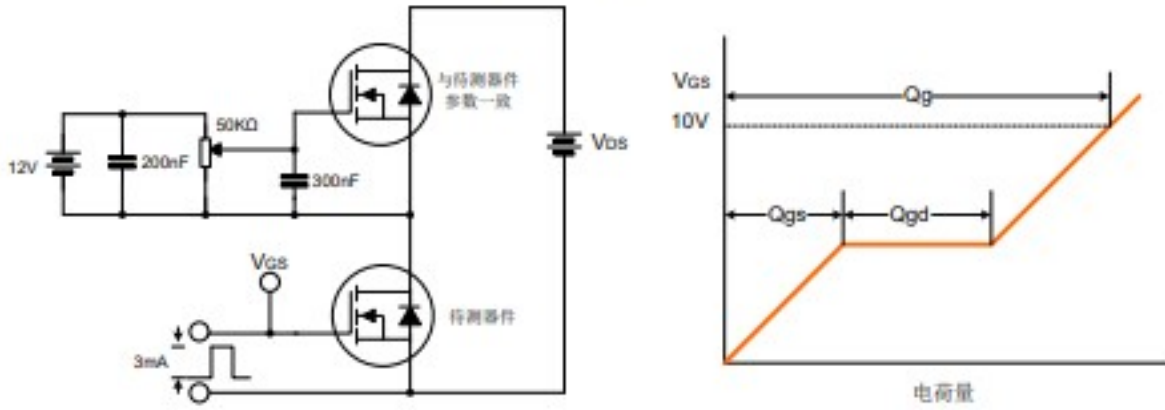

开关时间测试电路及波形图

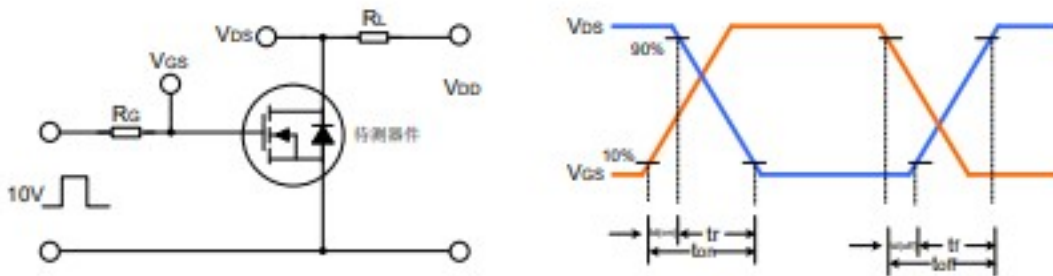

EAS测试电路及波形图

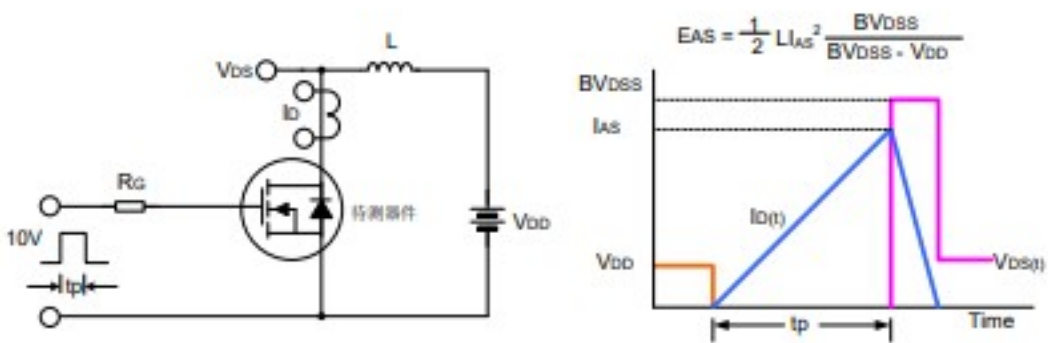

## Package Mechanical Data-TO-252-4R

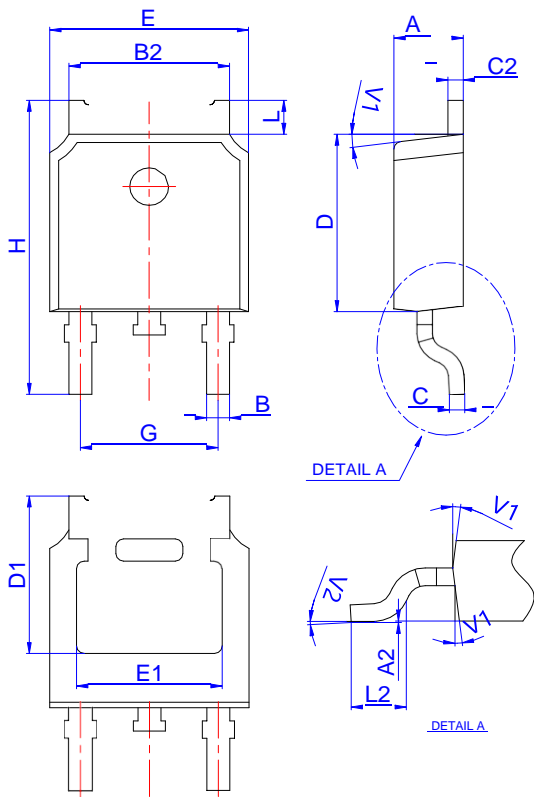

Ref.	Dimensions					
	Millimeters			Inches		
	Min.	Typ.	Max.	Min.	Typ.	Max.
A	2.10		2.50	0.083		0.098
A2	0		0.10	0		0.004
B	0.66		0.86	0.026		0.034
B2	5.18		5.48	0.202		0.216
C	0.40		0.60	0.016		0.024
C2	0.44		0.58	0.017		0.023
D	5.90		6.30	0.232		0.248
D1	5.30REF			0.209REF		
E	6.40		6.80	0.252		0.268
E1	4.63			0.182		
G	4.47		4.67	0.176		0.184
H	9.50		10.70	0.374		0.421
L	1.09		1.21	0.043		0.048
L2	1.35		1.65	0.053		0.065
V1		7°			7°	
V2	0°		6°	0°		6°

## Product Naming Rules

