

Description

EC70R38E N-channel Multi-Epi Super Junction MOSFETs

Features

700V, 11.0A
 Very low FOM $R_{DS(on)} \times Q_g$
 100% UIS tested
 RoHS compliant

Application

Power factor correction (PFC)
 Switched mode power supplies (SMPS)
 Uninterrupted power supply (UPS)



TO-252

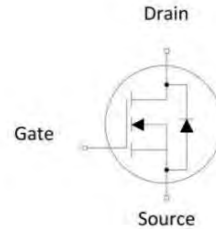

Schematic Diagram

Package Marking and Ordering Information

Device Marking	Device	OUTLINE	Device Package	TUBE (PCS)	Inner BOX (PCS)	Per Carton (PCS)
EC70R38E	EC70R38E	TAPING	TO-252	13inch	2500	25000

Absolute Maximum Ratings ($T_c=25^\circ\text{C}$ unless otherwise specified)

Symbol	Parameter	Max.	Units
V_{DSS}	Drain-Source Voltage	700	V
V_{GSS}	Gate-Source Voltage	± 30	V
I_D	Continuous Drain Current	$T_c=25^\circ\text{C}$	11
		$T_c=100^\circ\text{C}$	7
I_{DM}	Pulsed Drain Current	33	A
E_{AS}	Single Pulsed Avalanche Energy	210	mJ
P_D	Power Dissipation	$T_c=25^\circ\text{C}$	118
$R_{\theta JC}$	Thermal Resistance, Junction to Case	1.32	$^\circ\text{C/W}$
T_J, T_{STG}	Operating and Storage Temperature Range	-55 to +150	$^\circ\text{C}$

Electrical Characteristics (T_J=25°C unless otherwise specified)

Symbol	Parameter	Test Condition	Min.	Typ.	Max.	Units
Off Characteristic						
V _{(BR)DSS}	Drain-Source Breakdown Voltage	V _{GS} =0V, I _D =250μA	700	-	-	V
I _{DSS}	Zero Gate Voltage Drain Current	V _{DS} =700V, V _{GS} =0V	-	-	1	μA
I _{GSS}	Gate to Body Leakage Current	V _{DS} =0V, V _{GS} =±30V	-	-	±100	nA
On Characteristics						
V _{GS(th)}	Gate Threshold Voltage	V _{DS} =V _{GS} , I _D =250μA	2.5	-	4.0	V
R _{DS(on)}	Static Drain-Source on-Resistance	V _{GS} =10V, I _D =5.5A	-	340	380	mΩ
Dynamic Characteristics						
C _{iss}	Input Capacitance	V _{DS} =100V, V _{GS} =0V, f=1MHz	-	852	-	pF
C _{oss}	Output Capacitance		-	37	-	pF
C _{rss}	Reverse Transfer Capacitance		-	2.0	-	pF
Q _g	Total Gate Charge	V _{DD} =560V, I _D =5.5A, V _{GS} =10V	-	19.2	-	nC
Q _{gs}	Gate-Source Charge		-	3.1	-	nC
Q _{gd}	Gate-Drain("Miller") Charge		-	8.2	-	nC
Switching Characteristics						
t _{d(on)}	Turn-on Delay Time	V _{DD} =400V, I _D =5.5A, R _{GEN} =25Ω	-	16.3	-	ns
t _r	Turn-on Rise Time		-	35	-	ns
t _{d(off)}	Turn-off Delay Time		-	78	-	ns
t _f	Turn-off Fall Time		-	39.5	-	ns
Drain-Source Diode Characteristics and Maximum Ratings						
V _{SD}	Drain to Source Diode Forward Voltage	V _{GS} =0V, I _F =5.5A	-	0.85	-	V
t _{rr}	Body Diode Reverse Recovery Time	V _R =400V I _F =5.5A, dI/dt=100A/μs	-	310	-	ns
Q _{rr}	Body Diode Reverse Recovery Charge		-	2.8	-	μC

Typical Performance Characteristics

Figure 1. Output Characteristics

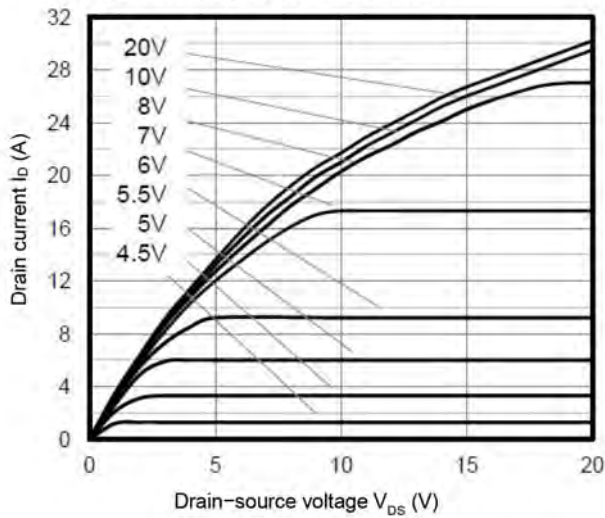

Figure 2. Transfer Characteristics

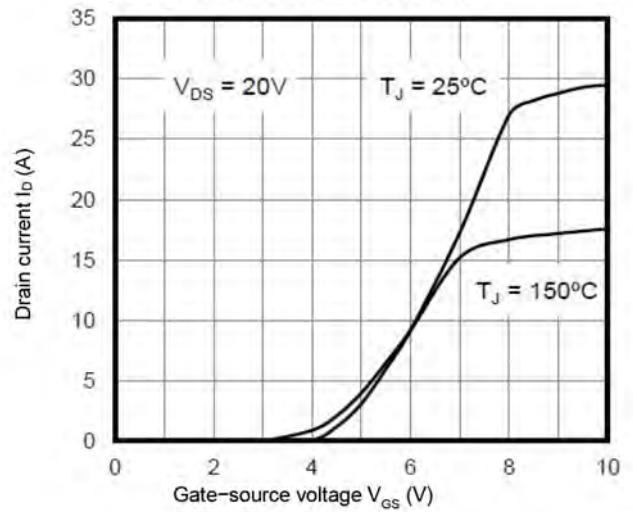

Figure 3. On-Resistance vs. Drain Current

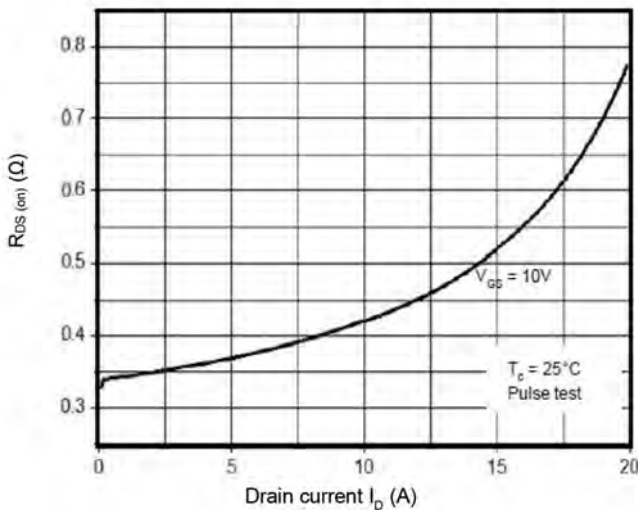

Figure 4. Capacitance Characteristics

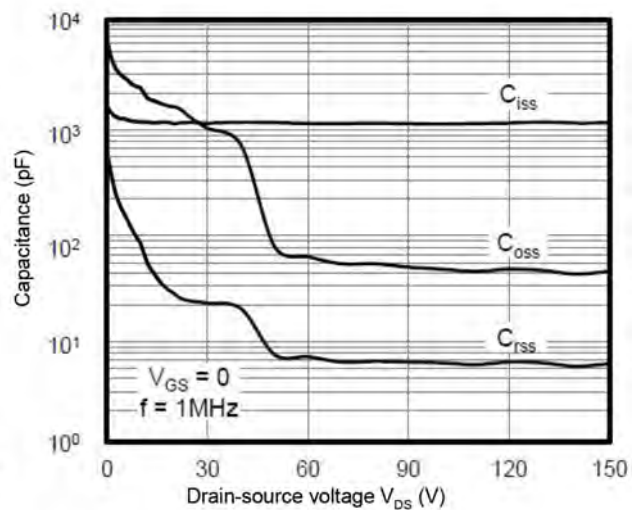

Figure 5. Gate Charge Characteristics

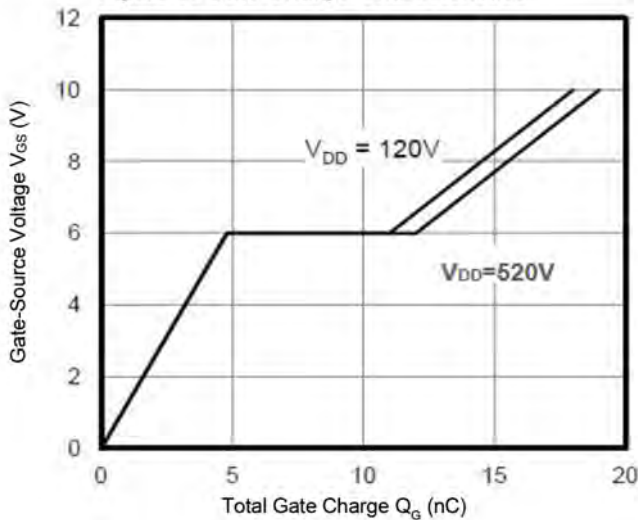

Figure 6. Body Diode Forward Voltage

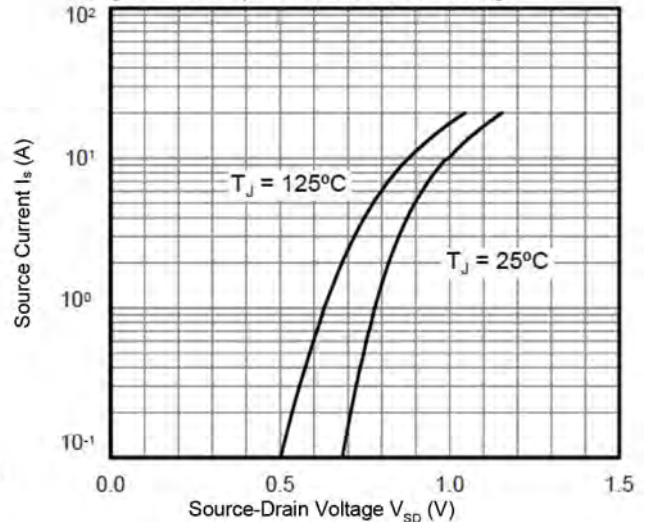

Figure 7. Breakdown Voltage vs. Temperature

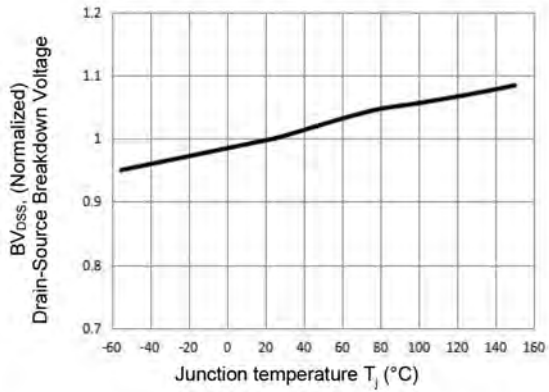

Figure 8. On-Resistance vs. Temperature

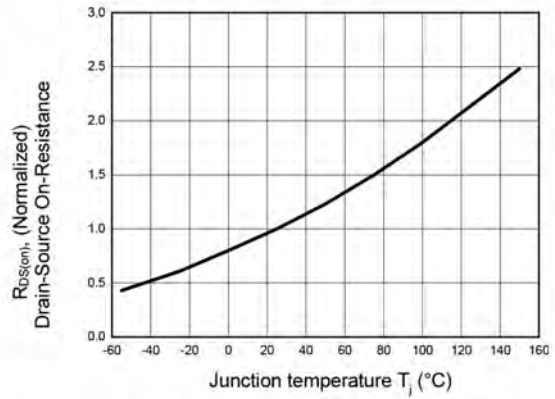

Figure 9. Maximum Safe Operating Area
TO-252/TO-251

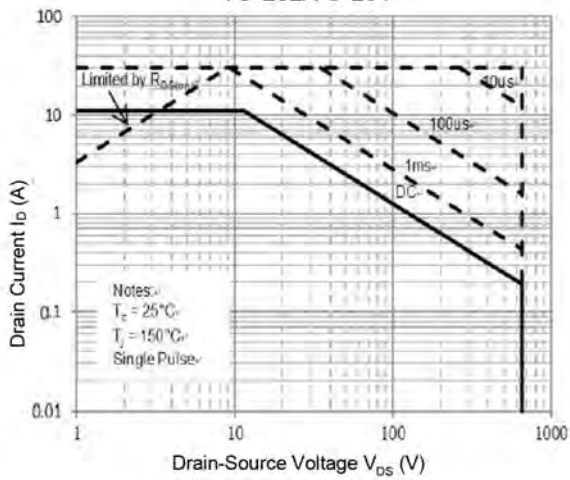
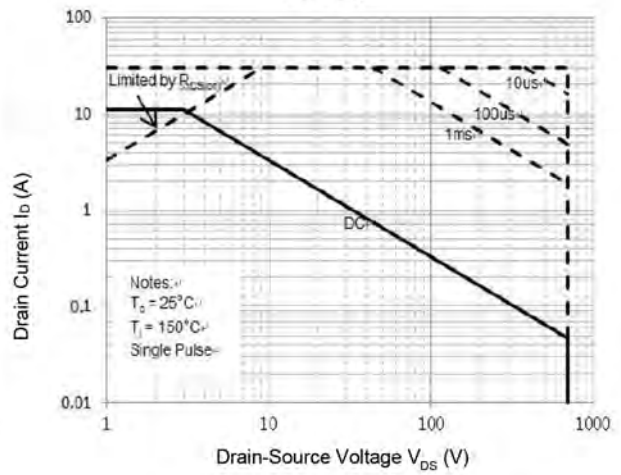
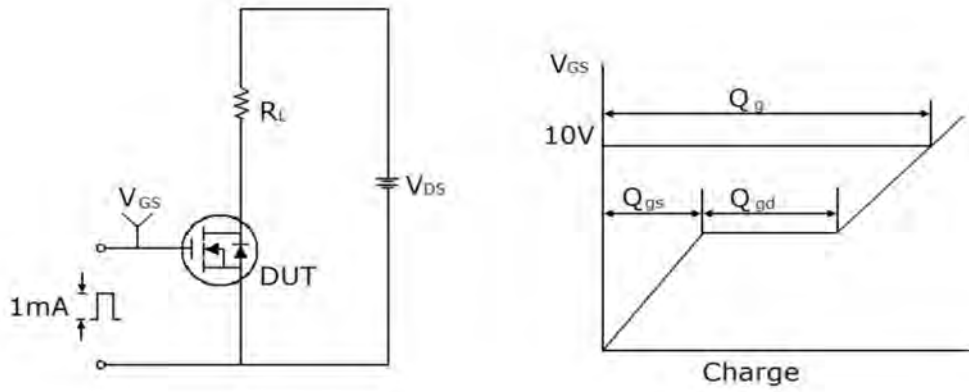

Figure 10. Maximum Safe Operating Area
TO-220F



Test Circuit

Gate Charge Test Circuit & Waveform



Switching Test Circuit & Waveform

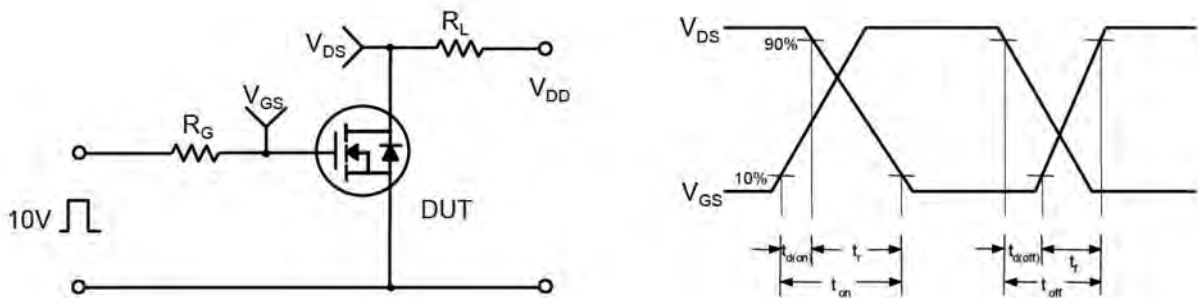

Unclamped Inductive Switching Test Circuit & Waveform

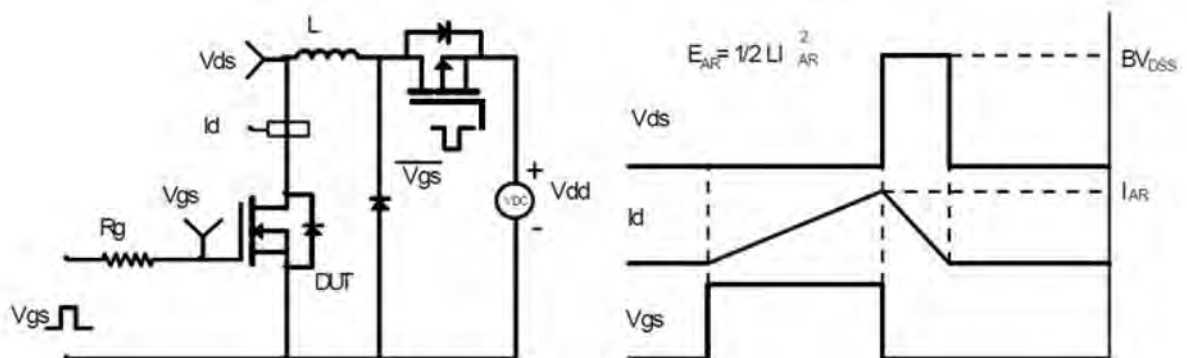

Package Mechanical Data-TO-252

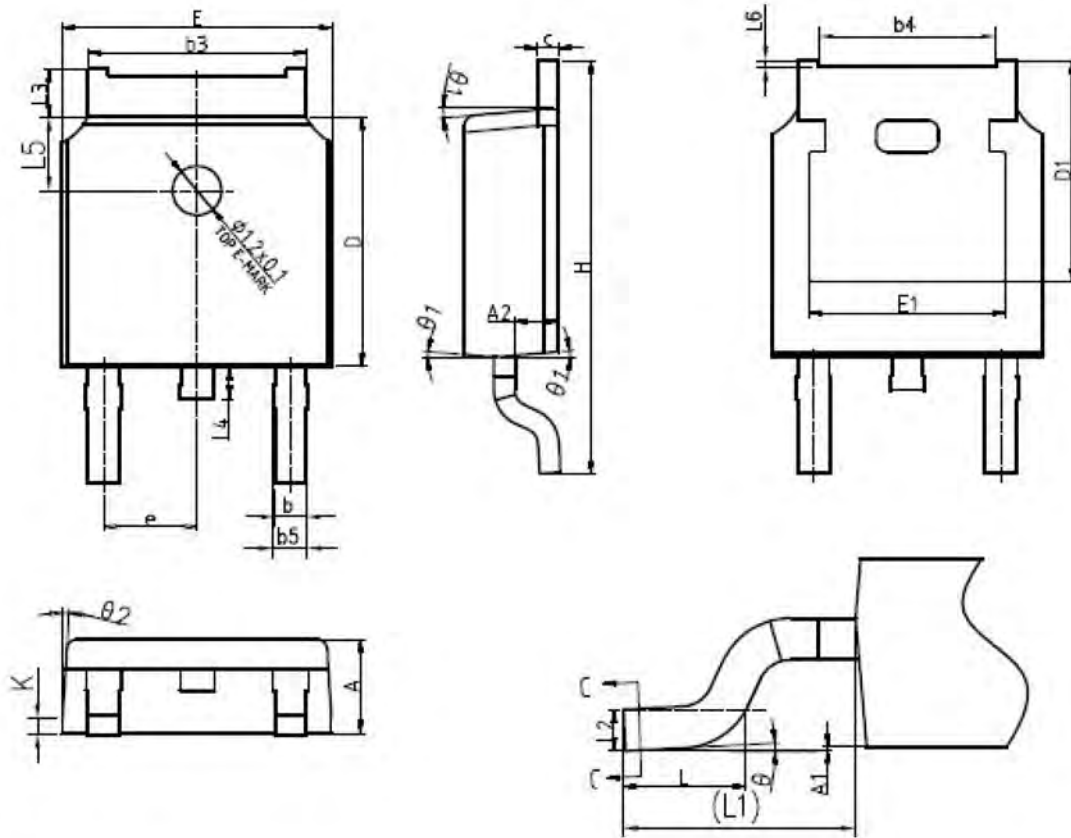

单位: mm

SYMBOL	mm		
	MIN	NOM	MAX
*A	2.20	2.30	2.38
*A1	0.00	-	0.10
A2	0.97	1.07	1.17
*b	0.72	0.78	0.85
b1	0.71	0.76	0.81
*b3	5.23	5.33	5.46
b4	4.27	4.32	4.37
b5	0.72	0.88	0.93
*c	0.47	0.53	0.58
c1	0.46	0.51	0.56
*D	6.00	6.10	6.20
D1	5.30REF		

*E	6.50	6.60	6.70
E1	4.70	4.83	4.92
*e	2.286BSC		
L	1.40	1.50	1.70
L1	2.90REF		
L2	0.51BSC		
*L3	0.90	-	1.25
*L4	0.60	0.80	1.00
L5	1.70	1.80	1.90
L6	0	0.047	0.123
θ	0°	-	8°
* θ 1	5°	7°	9°
θ 2	5°	7°	9°
K	0.40REF		

Product Naming Rules

