

INSTRUCTION MANUAL

NT311 ETH



1MN0199 REV. 0



operates with ISO9001 certified quality system

TECSYSTEM S.r.l.
20094 Corsico (MI)
Tel.: +39-024581861
Fax: +39-0248600783

<http://www.tecsystem.it>

R. 1.1 26/11/2020

ENGLISH

“Translations of the original instructions”

INTRODUCTION

Firstly, we would like to thank you for choosing to use a **TECSYSTEM** product, and we strongly suggest that you read this instruction manual carefully: It will allow you to understand use of the appliance and to take full advantage of all its features.

ATTENTION! THIS MANUAL IS VALID AND COMPLETE FOR THE NT311 ETH MODEL CONTROL UNIT THE NEW NT311 IS A TECSYSTEM DEVICE DESIGNED FOR THE ENVIRONMENTAL MONITORING OF PANELS AND TRANSFORMATION CABINS. THE NT311 DEVICE HAS BEEN DESIGNED TO ALLOW THE MAINTENANCE TECHNICIAN TO MONITOR TEMPERATURE, HUMIDITY, DUST DEPOSIT AND DOOR OPENING IN THE CABINS / PANELS. A USEFUL TOOL FOR PLANNING AND MANAGING MAINTENANCE INTERVENTIONS ON YOUR SYSTEM.

TABLE OF CONTENTS

	PAGE
1) SAFETY REQUIREMENTS	4
2) ACCESSORIES	5
3) TECHNICAL SPECIFICATIONS	6
4) TPU SENSOR	8
• TPU SENSOR CONNECTION NOTES	9
5) FRONT PANEL	—
• DISPLAY	10
• OPERATING PROGRAM CONTROL	—
• NOTES ON SCAN AND MAN FUNCTIONS	—
• LED TEST	—
• ALARM RELAY TEST	11
6) ASSEMBLY	—
7) ELECTRICAL CONNECTIONS	—
• NT311 ETH ELECTRICAL CONNECTIONS	12
• POWER SUPPLY	13
• ALARMS	—
• FAULT FAILSAFE	—
• FAULT AND RESET MESSAGE SEQUENCE	—
8) PROGRAMMING	14
• NT311	—
• PROGRAMMING NOTES	16
• SENSOR DIAGNOSTICS	—
• PROGRAMMED DATA DIAGNOSTICS	—
• MONITORED PARAMETER DIAGNOSTICS	17
• FAN & HEATER MANAGEMENT	18

	PAGE
9) OUTPUT ETHERNET MODBUS TCP	19
• INTRODUCTION TO THE ETHERNET MODULE	—
• OPERATING NOTES	—
• DATA TRANSMISSION	—
• NOTES ON ETHERNET ELECTRICAL CONNECTIONS	—
• FUNCTION CODE	—
• CODE 3(10).	—
• CODE 16(10).	—
• NOTES FOR REMOTE PROGRAMMING	20
• ERROR CODES	—
• ILLEGAL DATA	—
• MODBUS MAPPING TABLE	21
10) ETHERNET MODULE PARAMETER PROGRAMMING	25
• ETH0 CONNECTIONS	—
• TELNET ENABLING	—
• TELNET SCREEN	27
• IP PARAMETER PROGRAMMING MENU	28
11) WARRANTY REGULATIONS	30
12) TROUBLESHOOTING	—
13) EQUIPMENT DISPOSAL	31
14) USEFUL CONTACTS	—

SAFETY REGULATIONS



ATTENTION:

Read the manual carefully before starting to use the control unit. Keep the instructions for future reference.



Do not open the device. Touching any internal components can cause electric shock. Contact with a voltage over 50 Volts can be fatal. To reduce the risk of electric shock, do not dismantle the back of the device for any reason. Moreover its opening would void the warranty.

Before connecting the device to the power supply, make sure that all the connections are correct. Always disconnect the unit from the supply before any cabling modification.



Any work on the equipment must be entrusted to a qualified engineer.

Failure to comply with these instructions can cause damage, fires or electric shock, and possible serious injuries!

POWER SUPPLY

The NT311 control unit can be supplied by 85 to 260 VDC-VAC, irrespectively of the polarities in Vdc. Before using it, make sure the power cable is not damaged, knotted or pinched. Do not tamper with the power cable. Never disconnect the unit by pulling the cable and avoid touching the pins. Do not carry out any operations of connecting/disconnecting with wet hands. To disconnect the device, do not use objects such as levers. Immediately disconnect the device if you smell burning or see any smoke: contact assistance.

LIQUIDS

Do not expose the equipment to splashes or drops, do not position it in places with humidity exceeding 90% and never touch with wet or damp hands. If any liquid penetrates the control unit, disconnect it immediately and contact technical assistance.

CLEANING

Disconnect the power cable before cleaning the control unit, use a dry cloth to dust it, without any solvent or detergents, and compressed air.

OBJECTS

Never insert any objects into the cracks of the control unit. If this happens, disconnect the control unit and contact an engineer.

USE RESERVED TO QUALIFIED PERSONNEL

The purchased goods are a sophisticated electronic device that is completely unsuitable to be used by non-qualified personnel. Any work must be carried out by a specialist engineer.

ACCESSORIES

The use of non-original accessories or spare parts can damage the unit and endanger users' safety. In the event of faults, contact technical service.

LOCATION

Install the control unit indoors, in a place protected from water splashes and from the sun's rays. Do not place near heat sources exceeding the parameters stated in this manual. Position on a stable surface, far away from any possible vibrations. Position the unit as far as possible from any intense magnetic fields.

REPAIRS

Do not open the control unit. For any fault, always use qualified personnel. The opening of the control unit and/or the removal of the series identifying label entails the automatic forfeiture of the warranty. The Warranty seal is applied to all devices, any attempt to open the unit would break the seal and cause the consequent automatic forfeiture of the warranty.

TECHNICAL INFORMATION OR REPORTING INFORMATION

Mail: ufficiotecnico@tecsystem.it — tel: 02/4581861

ACCESSORIES

The following objects are present inside the box:

Control unit



Start guide and QR code



1 Terminal 3 poles pitch 5 supply
Code: 2PL0524

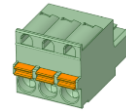

1 terminal 11 poles pitch 5 relays
Code: 2PL0528

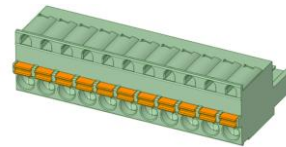

1 Terminal 4 poles pitch 3.81 TPU input
Code: 2PL0527

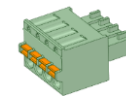

1 Terminal 3 poles pitch 3.81 doors input
Code: 2PL0523

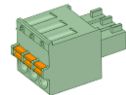

ATTENTION: always install the device using the terminals included in the pack.
The use of terminals other than those included with the control unit could cause malfunctions.

TECHNICAL SPECIFICATIONS	NT311 ETH
POWER SUPPLY	
Supply rated values	85-260 VDC-VAC 50/60Hz
Vdc with invertible polarities	•
INPUTS AND SENSORS	
1 TPU sensor input (temperature-humidity and dust)	•
2 inputs for NC door opening alarm contacts	•
Connections on removable terminal boards	•
OUTPUTS	
1 alarm relay (ALARM) SPDT	•
1 relay for sensor fault or SPDT operating anomaly (FAULT)	•
1 SPST FAN ventilation management relay	•
1 SPDT HEATER heating management relay	•
Output relays with 10A-250Vca-res COS Φ =1 contacts	•
TCP/IP Modbus Ethernet output	•
DIMENSIONS	
106.60x122x53.50mm	DIN rail
TESTS AND PERFORMANCE	
Construction in compliance with the EC regulations	•
Protection from electrical interferences EN 61000-4-4	•
Dielectric strength 1500 Vac for a min. between relay and TPU signal, relay and power supply, power supply and TPU signal	•
Ambient operating temperature from -20°C to +60°C	•
Permitted humidity 90% without condensate	•
Degree of protection IP20	•
UL 94V0 self-extinguishing PC/ABS Blend housing	•
3VA absorption	•
Self-diagnostic circuit	•
Electronic part protective treatment	Optional

TECHNICAL SPECIFICATIONS	NT311 ETH
DISPLAY AND DATA MANAGEMENT	
2 x 13 mm displays with 3 digits to display measured values, messages and channels	•
2 LEDs to display the state of the alarms (ALARM-FAULT)	•
2 LEDs selection of display mode (SCAN-MAN)	•
1 LEDs to display the state of FAN	•
1 LED to display the state of HEATER	•
1 high room temperature threshold HI TEMP (FAN)	From 10°C to 60 °C
1 low room temperature threshold TEMP.LO (HEATER)	From -25°C to 10°C
1 RH high humidity threshold (HEATER or FAN)	From 10%RH to 90%RH
1 DST high dust deposit threshold	From 10 dSt to 25 dSt
Door 1-Door 2 door alarm activation selection	•
Sensor failure diagnostics	•
Data memory diagnostics (Ech)	•
Access to programming through front keyboard	•
Automatic exit from programming, display and relay test after 1 minute of inactivity	•
Selection of display mode for scanning or manual	•
FAULT relay Fail Safe function	•

TECHNICAL SPECIFICATIONS	TPU SENSOR
1 NT311 digital BUS input	TPU IN
1 TPU sensor digital BUS output	TPU OUT
Internal temperature sensor	Reading range from -40°C to 70°C Tolerance 1% +/-1°C
Internal relative humidity sensor	Reading range from 0% RH to 90% RH tolerance +/-5%
3 Internal sensors for depositing of dust	Reading range from 6 dSt to 30 dSt offset +/-2 dSt
Temperature of work environment	From -40°C to +70°C
Permitted humidity 90% without condensate	•
Degree of protection IP20	•
Housing PC UL 94 HB	•
Electronic part protective treatment	Optional
DIMENSIONS	
110x50.1x35mm	Fixing holes Ø5mm 100mm
TPU sensor fixing bracket	Optional

TPU SENSOR

The TPU sensor has been designed with the aim of monitoring the environmental conditions of: **temperature, dust deposit and humidity**. Place the sensor in an area protected from air flows, typically 2/3 of the total height of the environment to be monitored (choice of installer according to the characteristics of the system). The area above the dust sensors should be kept clear up to a distance of approximately 30cm.

Fix the TPU sensor on a flat surface using the appropriate anchoring holes, M4 screws with washer.

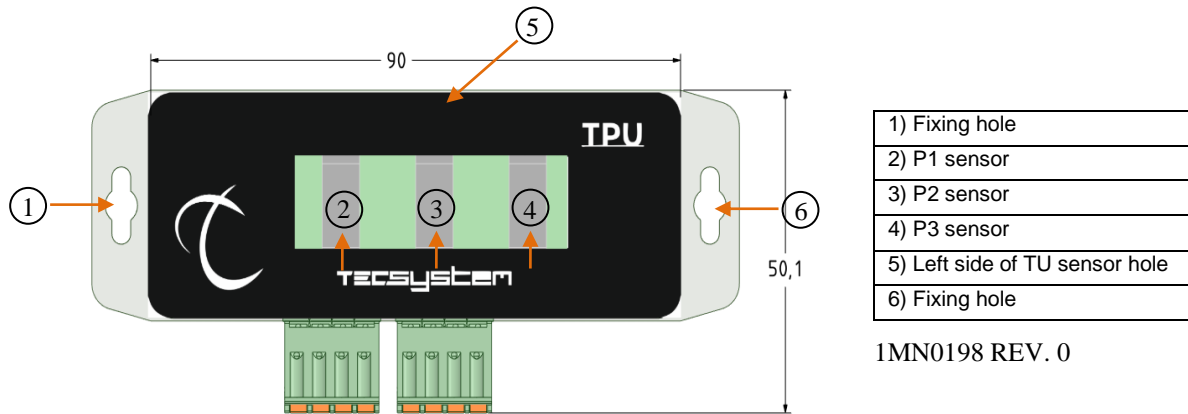

TPU SENSOR NOTES : do not fix the sensor upside down and do not cover the P1-2-3 dust detection sensors. Never block the TU sensor input. Do not place near strong magnetic fields or excessive heat sources (higher than the product specifications). Remove the dust with a brush and clean the sensor only with a dry cloth.

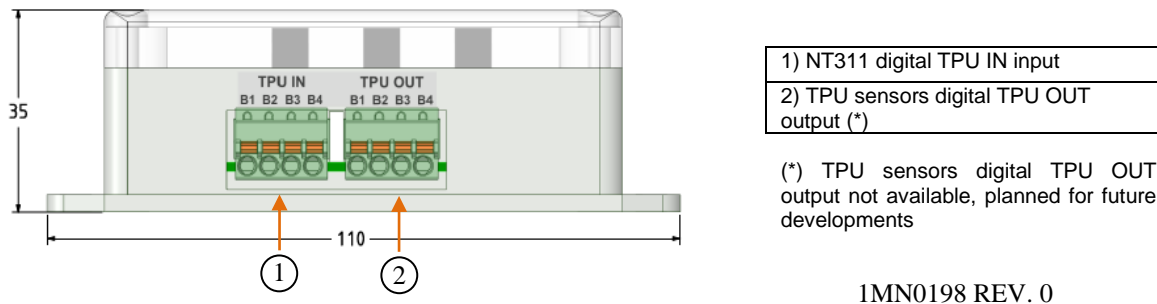

Connections:

Connect the TPU IN input to the NT311 control unit, respecting the numbering **B1-B2-B3-B4** , info on pages 12 and 13.



POWDER DEPOSIT IDENTIFICATION NOTES:

The response of the dust sensor depends on the characteristics of the dust deposit, such as: thickness, colouring and material. It should be noted that: coarse deposits, dark colours (carbon black type) or the formation of condensation can alter reading of the dust deposit sensors.

TPU SENSOR CONNECTION NOTES

The TPU sensor must be connected to the control unit using the appropriate cable; the electrical connections are shown on page 12/13.

Note: All the signal transportation cables must strictly:

- be separated from those of power
- be created with shielded cable with twisted conductors
- have a section of at least 0.25 mm²
- be twisted if the shield does not exist
- be firmly fixed in the terminal blocks
- have tin-plated or silver-plated conductors

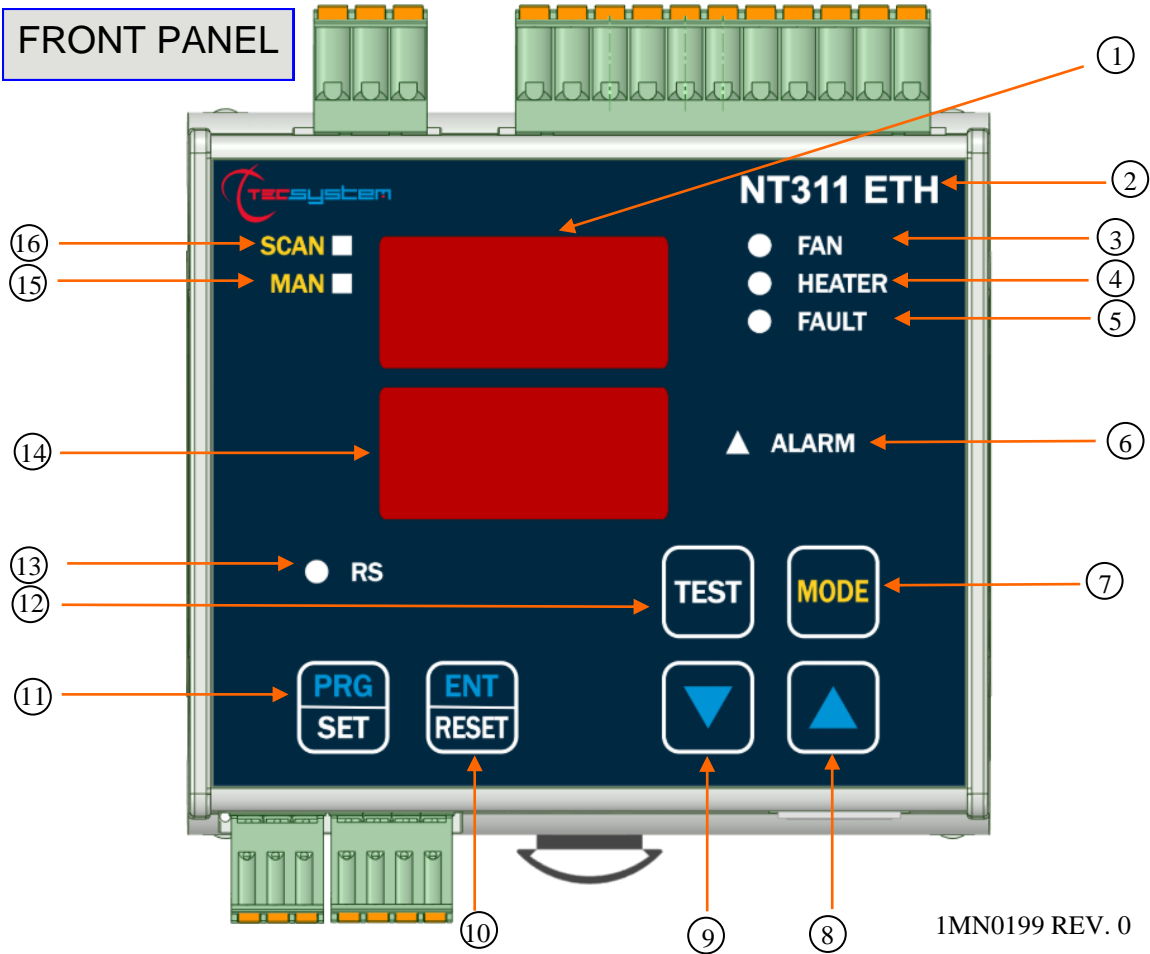

1)	3-digit display for values measured	9)	DOWN key
2)	Control unit series	10)	Enter/Reset button
3)	FAN signalling (red) LED	11)	Programming/Setting key
4)	HEATER signalling (yellow) LED	12)	Led/relay test key
5)	FAULT (red) LED	13)	Modbus communication RS (green) LED
6)	ALARM (yellow) LED	14)	3-digit display viewing of parameters
7)	MODE display mode selection key	15)	Man mode selection (yellow) LED
8)	UP key	16)	Scan mode selection (yellow) LED

DISPLAY

The first display is dedicated to viewing of the measured values and the status of the doors (OPE-CLO).

The second display shows the monitored value: temperature (°C), humidity (rh), dust (dst), D1-D2 door inputs.

When the device is turned on or after a reset, the following always appear on the display: the model of the NT311 control unit, VER "00" (firmware version), ETH (Ethernet option).

Pressing the MODE key, the display modes can be set:

- **SCAN:** the control unit displays in scan (every 2 seconds) all the enabled parameters, disabled parameters (NO).
- **MAN:** manual reading of the enabled parameters using the up/down keys ▲▼, parameters disabled (NO).

NOTE: in case of keyboard inactivity, after approximately 1 minute, the control unit will automatically set itself in **SCAN** mode.

OPERATING PROGRAM CONTROL

To check the programmed protection levels, press the PRG key to enter the **VIS** program viewing mode.

Repeatedly pressing the PRG key, you can scroll through all the previously loaded values in sequence.

After 1 minute's keyboard inactivity, the programming display procedure is automatically abandoned.

To stop the display, press the ENT key.

NOTES ON SCAN AND MAN FUNCTIONS

During the SCAN and MAN modes, the operation of the NT311 can be displayed.

1) RUN cPU:

This message appears when the unit is operating regularly without any system error.

2) cPU Err:

This message appears when the device detects an operating anomaly. By pressing the MODE key and selecting the MAN mode, it is possible to view the error message encountered by the device.

Using the arrow ▲ (UP) anomalies with the following priority will be visible:

- a) Ech Err:** This message appears when damage in the EEPROM memory is detected. Pressing Reset will cancel the message and restore the original default parameters listed in the programming paragraph on pages 14-15. Return the control unit to TECSYSTEM for repairs.

This message appears when it is found that one or more sensors are not working properly:

- b) FLT-TEC** TPU sensor communication failure
- c) FLT- °C** temperature sensor fault
- d) FLT-rH** humidity sensor failure
- e) FLT-dSt** dust sensor failure

In case of **Err** the FAULT relay will be de-energised (fail safe function active).

NOTES: In the case of ERR-TEC, TPU errors will not be visible as information from the sensors is missing. The next step is the values. Pressing the key ▼ (DOWN) will display the temperature.

LED TEST

It is advisable to regularly test the control unit LEDs.

For this operation, press the TEST key briefly; all the displays turn on for 2 seconds.

If one of the LEDS does not work, please return the control unit to TECSYSTEM for repair.

ALARM RELAY TEST

This function allows you to carry out a test of the relay operation without having to use further devices. To start the test procedure, press and hold the TEST button for approximately 5 seconds: the **TST** indication appears for 2 seconds confirming entry into the Relays Test mode.

The lit LED indicates the relay to be tested, use the cursors ▲▼ to select the desired relay.

Press the SET and RESET keys to energise and de-energise the relay to be tested; the display will show ON-OFF.

After 1 minute's keyboard inactivity, the RELAY TEST procedure will be automatically abandoned.

To stop the RELAY TEST procedure, press the TEST key.

ASSEMBLY

Attach the device to the DIN rail and make the connections to the removable terminal blocks.

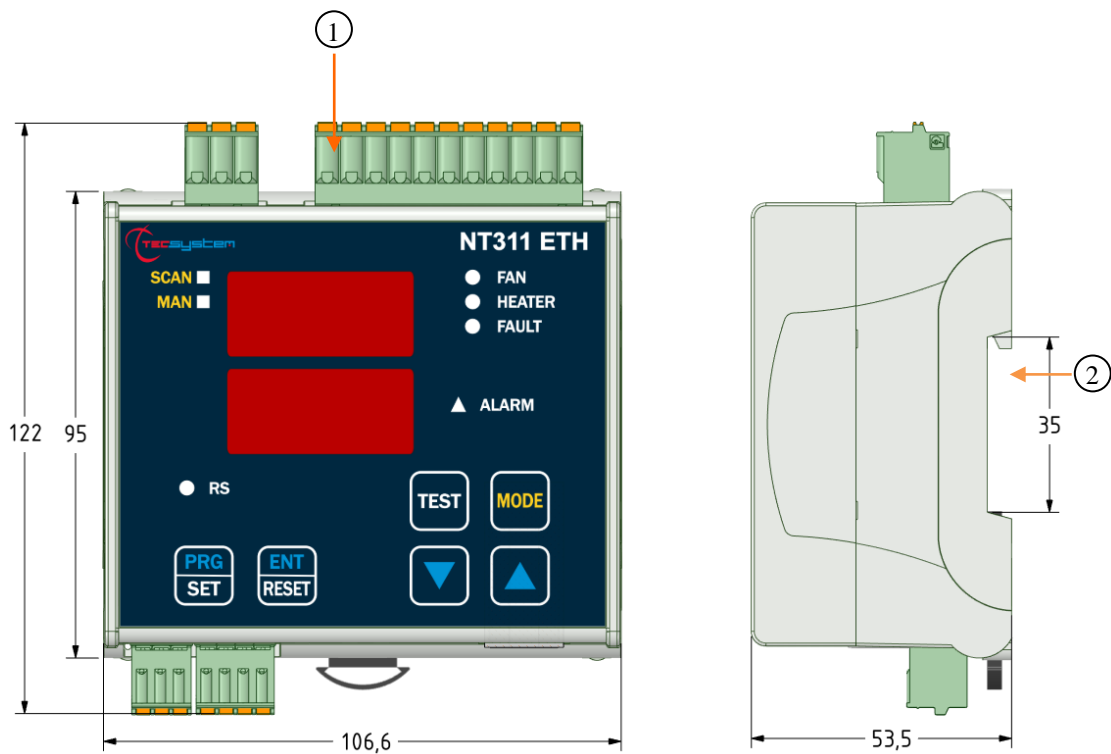

1MN0199 REV. 0

1)	Control unit	2)	DIN rail assembly
----	--------------	----	-------------------

ELECTRICAL CONNECTIONS

NT311 ETH

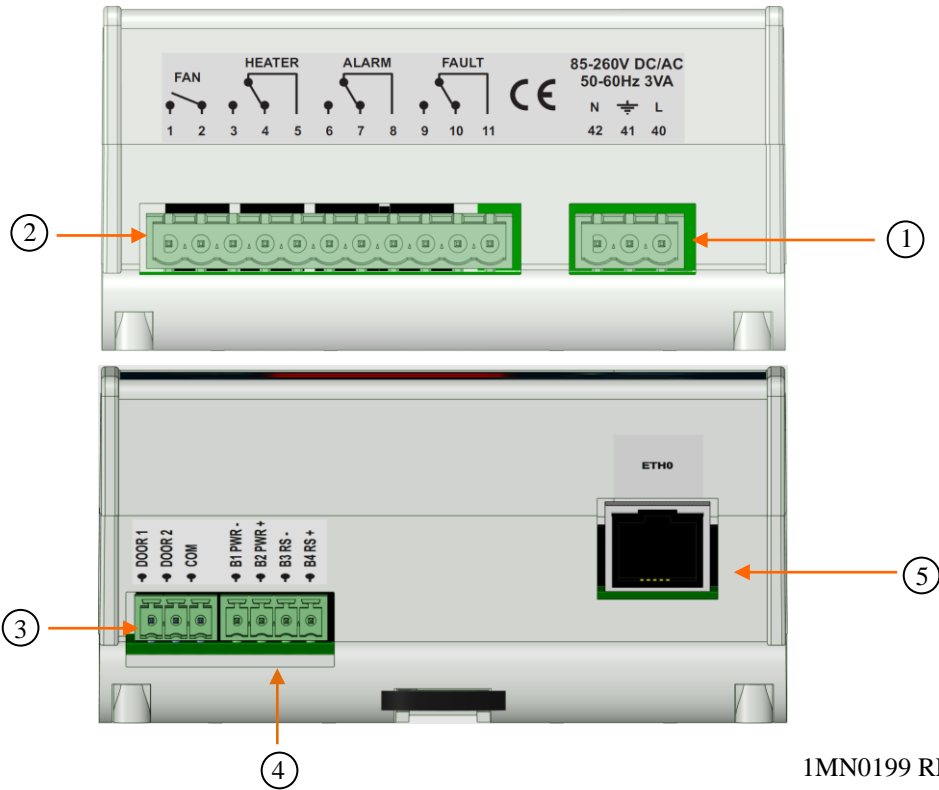

1MN0199 REV. 0

1)	Relays (AUX-ALARM-TRIP-FAULT)	4)	Sensor digital input TPU B1-B2-B3-B4
2)	85-260Vcc-ca 50/60Hz power supply.	5)	Modbus TCP / IP ETH0 Ethernet port
3)	Door contact input Door1 and Door2		

Note: image of relay contacts in non-alarm condition except for the FAULT relay, which switches: contacts 9-11 closed (NO) contacts 10-11 open (NC). Read the alarms paragraph p. 13 and see image fault contact switching.

RELAYS CONNECTION EXAMPLE

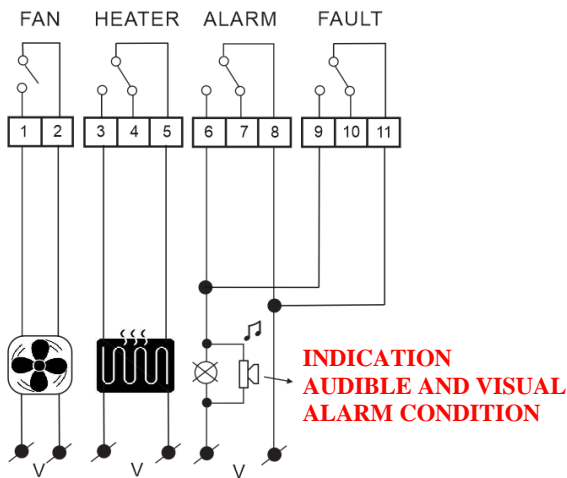

Output relay with contacts of 10A-250Vca-res COSΦ=1.

1MN0196 REV. 0

EXAMPLE DOORS CONNECTION

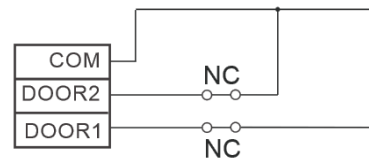

TPU SENSOR CONNECTION EXAMPLE

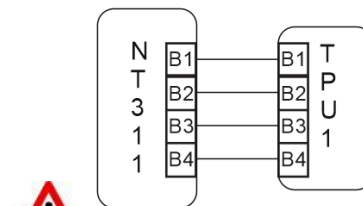

Attention!

For the TPU sensor control unit connection, see the TPU sensor connection notes on page 9.

POWER SUPPLY

The NT311 control can be supplied by 85 to 260 Vac-Vdc, 50/60 Hz irrespectively of polarity in Vdc (terminals 40 - 42).

This particularity is obtained thanks to the use of a tested power supply, of new conception and realisation, which frees the installer from any uncertainty regarding the correct Vac or Vdc power supply.

The earthing cable must always be connected to terminal 41.

To protect the control unit against line overvoltages, the PT-73-220 electronic arrester, designed by TECSYSTEM S.r.l. for this specific purpose, is recommended. Alternatively, it is advisable to use 110 V AC supply voltages or, even better, 110 VDC.

If an existing control unit must be replaced with a new one, to guarantee its correct and safe operation, the sensor/relay/supply connecting terminals must be replaced with the new terminals supplied.

ALARMS

Carry out the electrical connections on the removable terminal blocks only after disconnecting them from the unit.

When the control unit is in one of the following modes, it does not perform any monitoring, moreover the relays will all be disabled, the fault contact switches and the fault LED will flash.

- Programming viewing display.
- PRG programming.
- Relay test.

The ALARM, FAN and HEATER relays only switch when the set limits are exceeded, see paragraph on the monitored value diagnostics.

The FAULT (fault) contact, programmed in active failsafe mode (default YES), opens when the appliance is powered, only if during the access phase the control unit does not detect anomalies, and keeps the switching until when one of the following events occurs:

- Data memory fault (Ech message).
- TEC sensor fault -°C -dSt - rH.
- Insufficient supply voltage.
- During the power on reset after programming (PRG), displaying of the data (VIS) and relay test.

FAULT CONTACT OPERATION

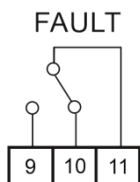

FAULT 10-11 NC: ALARM FAULT OR POWER OFF

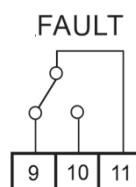

FAULT 10-11 NO: POWER ON OR NO FAULT

FAULT FAILSAFE

By setting YES (Fail safe), contact 9-11 is positioned as normally open and switches (closed) when a fault condition is identified. Setting NO (NO Fail safe) the contact 10-11 is positioned as normally closed and switches (open) when a fault condition is identified.

If the fail safe function is disabled on the fault contact, the control unit will no longer be able to signal the fault due to power failure.

NOTE: always disconnect the unit before performing any electrical connections.























FAULT AND RESET MESSAGE SEQUENCE

Find below the sequence of fault messages and RESET function condition.

- | | | |
|------------|----------------------------|--------------------------|
| 1) ECH | eeptom fault | erasable message |
| 2) ERR TEC | sensor communication fault | non-resettable condition |
| 3) ERR °C | sensor fault | non-resettable condition |
| 4) ERR dSt | sensor fault | non-resettable condition |
| 5) ERR rH | sensor fault | non-resettable condition |

PROGRAMMING

NT311 ETH

PITCH	PRESS	EFFECT	PRESS	NOTES
1		Press and hold the PRG button until the display shows SET PRG		
2		Select PRG SET to proceed with programming or PRG 1 to load the default values		PRG 1 default data
3		High environment temperature management Thi		Default YES
4		Select YES or NO		
5		Maximum ambient temperature programming Thi		
6		Set the desired threshold		Default 40°C
7		Enable ventilation management relay (FAN)		FAN LED flashes
8		Select YES or NO		Default YES
9		Enabling of air alarm relay		ALARM LED flashes
10		Select YES or NO		Default YES
11		Low ambient temperature management Tlo		Default YES
12		Select YES or NO		
13		Minimum ambient temperature programming Tlo		
14		Set the desired threshold		Default 5°C
15		Enabling of heater management relay (HEATER)		HEATER LED flashes
16		Select YES or NO		Default YES
17		Enabling of air alarm relay		ALARM LED flashes
18		Select YES or NO		Default YES
19		High ambient humidity management rH		
20		Select YES or NO		Default YES
21		Maximum ambient humidity programming rH		
22		Set the desired threshold		Default 70rH

23		Enabling of heater or ventilation relay		no LED HEATER LED flashes FAN LED flashes
24		Set NO-HEATER (HTR) - FAN	 	Default HTR
25		Enabling of air alarm relay		ALARM LED flashes
26		Select YES or NO	 	Default YES
27		Dust presence management dst		
28		Select YES or NO	 	Default YES
29		Dust maximum threshold programming dst		
30		Set the desired threshold	 	Default dst 16
31		Enabling of air alarm relay		ALARM LED flashes
32		Select YES or NO	 	Default YES
33		Enabling of input door 1 D1		
34		Select YES or NO	 	Default YES
35		Enabling of air alarm relay		ALARM LED flashes
36		Select YES or NO	 	Default YES
37		Enabling of input door 2 D2		
38		Select YES or NO	 	Default YES
39		Enabling of air alarm relay		ALARM LED flashes
40		Select YES or NO	 	Default YES
41		FLS (FAULT) is displayed Blinking FAULT LED		
42		Select YES or NO	 	Default YES
43		END is displayed		End of programming
44		Press ENT to save the set data and exit programming		
45		Return to step 1		See programming notes p.16



ATTENTION:

We recommend you check the device's programming before starting the device. The default parameters set by TECSYSTEM might not match your requirements.

Programming the device is the end user's responsibility, the settings of the alarm thresholds and the enabling of the functions described in this manual must be checked (by a specialized engineer) according to the application and features of the system the control unit is installed on.

PROGRAMMING NOTES

- 1) The MODE key allows reversing of the programming steps.
- 2) The TEST key allows exiting programming without saving the modified data.
- 3) After 1 minute's keyboard inactivity programming is abandoned without saving the data.
- 4) During programming the control unit does not control/protect the monitored machine.
- 5) At the end of programming the control unit is restarted and the FAULT relay is disabled until the unit is fully restarted.
- 6) When a parameter is disabled, "NO" skips the programming step.

SENSOR DIAGNOSTICS

In the event of a fault or if the maximum full scale value of one of the sensors is exceeded, the FAULT relay switches instantly, with the relative indication of a faulty sensor.

FAULT TEC (FLT TEC) TPU sensor disconnected, it is advisable to check the connection between the sensor and the control unit.

NOTE: any disturbances on the sensor line can generate incorrect readings or communication problems between the devices. Data transmission is not guaranteed.

FAULT °C (FLT °C) in case of a breakage or readings beyond the full scale (110°C) there is instantaneous switching of the relay of FAULT, with the relative indication of the faulty temperature sensor (FLT°C).

FAULT rH (FLT rH) in the event of breakage or readings beyond the full scale (97% rH) there is instantaneous switching of the FAULT relay, with the relative indication of the faulty humidity sensor (FLT rH).

FAULT dSt (FLT dSt) in the event of breakage or readings beyond the full scale (30) there is instantaneous switching of the FAULT relay, with the relative indication of the faulty dust deposit sensor (FLT dSt).

NOTE: the TPU sensor diagnostics is reported: in the modbus register 14 CPU ERROR. Furthermore, by pressing the MODE key and selecting the MAN mode, it is possible to display the error message encountered by the device. By pressing the arrow ▲ (UP) the anomalies will be visible.

To eliminate the message and to restore the Fault switching, check the connections and replace the faulty sensor if necessary. In case the maximum full scale value has been reached, make sure that the environmental conditions correspond to what is indicated by the control unit.

PROGRAMMED DATA DIAGNOSTICS

In case of failure of the internal memory or corruption of programmed data, just after switching on, **Ech** appears with the relevant Fault contact signal.

In this case, for safety reasons, the default parameters are loaded automatically (see programming table on pages 14 to 15).

Eliminate the **Ech** indication by pressing RESET and run programming to enter the desired values.

Finally switch the unit off and back on to check the memory works correctly, if it is damaged **Ech** will be displayed again (send the control unit to TECSYSTEM srl for repairs).

MONITORED VALUES DIAGNOSTIC

The alarm parameters must be configured by programming see programming table on pages 14-15.

THi temperature

The alarms relating to the THi temperature parameter can be programmed with a range between 10°C and 60°C, with steps of 1°C. The THi parameter can be enabled "YES" and disabled "NO". With NO programming, the THi parameter is not considered, with YES the following takes place:

When the sensor detects a temperature higher than 1°C, compared to the pre-set value as Th limit (**THi +1°C**), the FAN relay switches and the FAN LED lights up. With temperature higher than 6°C, compared to the pre-set value as Th limit (**THi +6°C**), The ALARM relay switches and the ALARM LED flashes. Association of the relays with the THi parameter occurs during programming:

- FAN extraction fans enabling (YES enabled-NO disabled)
- ALARM high temperature WARNING signal (YES enabled-NO disabled)

As soon as the measured temperature returns to values that are lower than the pre-set limit, the relays switch and the LEDs FAN (THi-1°C) and ALARM (THi +4°C) turn off. **NOTE: temperature monitoring every 2 seconds.**

Example of alarm activation with THi = 45°C

	ON		OFF	
FAN	46°C	THi + 1°C	44°C	THi - 1°C
ALARM	51°C	THi + 6°C	49°C	THi + 4°C

Tlo temperature

The alarms relating to the Tlo temperature parameter can be programmed with a range between -25°C and 10°C, with steps of 1°C. The Tlo parameter can be enabled "YES" and disabled "NO". With NO programming, the Tlo parameter is not considered, with YES the following takes place:

When the sensor detects a temperature lower than 1°C, compared to the pre-set value as Tlo limit (**Tlo -1°C**), the HEATER relay switches and the HEATER LED lights up. With temperature lower than 6°C, compared to the pre-set value as Tlo limit (**Tlo -6°C**), The ALARM relay switches and the ALARM LED flashes. Association of the relays with the Tlo parameter occurs during programming:

- HEATER "panel / cabin heating element" heater enabling (YES enabled-NO disabled)
- ALARM low temperature WARNING signal (YES enabled - NO disabled)

As soon as the measured temperature returns to values that are greater than the pre-set limit, the relays switch and the LEDs HEATER (Tlo+1°C) and ALARM (Tlo-4°C) turn off. **NOTE: temperature monitoring every 2 seconds.**

Example of alarm activation with TLo = 5 ° C

	ON		OFF	
HEATER	4°C	Tlo - 1°C	6°C	Tlo + 1°C
ALARM	-1°C	Tlo - 6°C	1°C	Tlo - 4°C

Humidity RH

The alarms relating to the humidity parameter rH can be programmed with a range between 10 - 90% RH, with steps of 1%. The rH parameter can be enabled "YES" or disabled "NO". With NO programming, the RH parameter is not considered, with YES the following takes place:

When the sensor detects a humidity rate higher than 1% compared to the pre-set value as the limit of RH (**RH +1%**), the FAN / HEATER relays switch and the FAN / HEATER LEDs light up. With humidity rate higher than 6%, with respect to the pre-set value as limit RH (**RH +6%**), the ALARM relay is switched and the ALARM LED flashes. Association of the relays with the rH parameter occurs during programming:

- FAN / HEATER enabling of extraction fans or heaters (panel / cabin heating element) (NO disabled-HEATER "hTr enabled heater" - FAN enabled fan)
- ALARM WARNING humidity (YES-NO enabled disabled)

The switching off of the FAN / HEATER and ALARM alarms occurs as soon as the humidity detected returns to -4% below the pre-set limit RH, in which case the relays are switched and the LEDs FAN / HEATER (RH - 4%) and ALARM (RH + 1%) turn off. **NOTE: humidity monitoring every 2 seconds. Maximum value for switching the ALARM relay rH 97%.**

Example of alarm activation with rH = 60%

	ON		OFF	
HEATER/FAN	61%	RH + 1%	56%	RH -4 %
ALARM	66%	RH + 6%	61%	RH +1 %

Dust deposit dSt

The alarms relating to the dust parameter dSt can be programmed with a range between 10 to 25 dSt, with steps of 1 dSt. The dSt parameter can be enabled "YES" or disabled "NO". With NO programming, the dSt parameter is not considered, with YES the following takes place:

When the sensor detects a value greater than 1 dSt with respect to the value set as the limit of dSt (dSt +1), the relay ALARM switches and the ALARM LED flashes. The association of the relays with the dSt parameter occurs during programming:

- ALARM WARNING dust deposit (YES enabled-NO disabled)

As soon as the conditions of dust deposit detected return to values equal to or lower than the pre-set limit, the relays are switched and the LEDs ALARM (dSt-1) turns off. In the case of ALARM dSt, the cleaning of the cabin is recommended.

NOTE: monitoring of dust conditions every 24 hours, starting from the last activation of the TPU sensor (first reading).

Example of alarm activation dst = 16

	ON		OFF	
ALARM	17	dSt + 1	15	dSt -1

Door inputs D1-D2

The NT311 control unit has two door inputs D1 and D2, Door 1 – Door 2- Com connections. Enabling of the D1 and D2 inputs allows monitoring of the status of the door contacts (NC), see example of connection on page 13 or 14.

With the enabled parameter, D1 or D2 YES, opening of the contact connected follows the switching of the the relay ALARM switches and the ALARM LED flashes. Association of the relays with the D1-D2 parameter occurs during programming:

- **ALARM** door **WARNING** signal (YES enabled-NO disabled)

Display view

- OPE = open contact (alarm condition)
- CLO = contact closed (non-alarm condition)

FAN & HEATER MANAGEMENT

The NT311 control unit has two relays: FAN and HEATER that are used to manage the temperature of the cabin / panel in which it is installed.

FAN (THi)

If appropriately programmed, through the **THi** threshold, it can control the ON-OFF of the cabin / panel extraction fans.

e.g. THi = 30°C (FAN "YES") when the THi threshold is exceeded by 1°C, example (31°C), the FAN LED lights up and the FAN relay switches. When the temperature goes below the programmed threshold of (-1°C) THi, example 29°C, the relative relay switches and the FAN LED turns off.

The high flexibility of the NT311 control unit allows the enabling of contact management:

By selecting **FAN "YES"** the function will be disabled.

By selecting **FAN "NO"** the function will be disabled.

The THi threshold can be programmed in the programming steps 5-6 on page 14.

HEATER (Tlo)

If appropriately programmed, through the **Tlo** threshold, it can control the ON-OFF of the heating system (heating element) of the cabin / panel.

e.g. Tlo = 5°C (HEATER "YES") when the temperature goes below the threshold of (-1°C) Tlo, example 4°C, the HEATER LED lights up and the relay switches HEATER. When the temperature exceeds (1°C) the programmed Tlo threshold, example 6°C, the relative relay switches and the HEATER LED turns off.

The high flexibility of the NT311 control unit allows the enabling of contact management:

By selecting **HEATER "YES"** the function will be disabled.

By selecting **HEATER "NO"** the function will be disabled.

The Tlo threshold can be programmed in the programming steps 13-14 on page 14.

FAN & HEATER (RH)

If appropriately programmed, through the **rH** threshold, it can control the ON / OFF of the cabin / panel heater (heating element) or the ON / OFF of the cabin / panel extraction system.

ES: RH = 80% (HEATER "hTR") when the control unit detects a humidity level that is 1% higher than the pre-set value RH, example (81% RH), the HEATER LED lights up and the HEATER relay switches. When the control unit detects a humidity rate that is -4% lower than the pre-set value, example 76%, the relative relay switches and the HEATER LED turns off.

ES: RH = 80% (FAN "FAN") when the control unit detects a humidity rate that is 1% higher than the pre-set value RH example (81% RH), the FAN LED lights up and the FAN relay switches. When the control unit detects a humidity rate that is -4% lower than the pre-set value, example 76%, the relative relay switches and the FAN LED turns off.

The high flexibility of the NT311 control unit allows the enabling of contact management:

By selecting **HEATER "hTR"** the function will be enabled on the relative HEATER contact.

By selecting **FAN "FAN"** the function will be enabled on the relative FAN contact

By selecting **"NO"** the function will be disabled.

The rH threshold can be programmed in steps 21-22 of the programming on page 14.



IMPORTANT INFORMATION

Before carrying out the insulation test of the electrical panel, on which the control unit is installed, it must be disconnected from the power supply line and the sensors disconnected, in order to prevent them from being seriously damaged.

OUTPUT ETHERNET MODBUS TCP

INTRODUCTION TO THE ETHERNET MODULE

The Ethernet connectivity of the new NT311 ETH is used to implement the functions of the Tecsystem control units directly into your Modbus TCP maximum 8 node monitoring system.

The integrated module includes all the essential network features, among which a 10Base T/100 Base-TX Ethernet connection, complete stack TCP / IP, suitable to work as an Modbus TCP slave.

The unit can be used for remote configuration, monitoring in real time or problem solving.

The Windows-based Telnet system allows configuring the NT311 ETH easily into a sub-network with specific IP addresses.

OPERATING NOTES

The communication of the temperature control monitoring unit is active only when the NT311 ETH is in temperature control mode (Scan, Man).

When other functions such as programming, programming display and relay test are activated, the ModBus communication is temporarily deactivated.

DATA TRANSMISSION

The Ethernet module allows you to connect to the control unit via Modbus TCP slave allowing you to: read the data indicated in the modbus table p. 21 and to be able to write those indicated in the paragraph notes for remote programming.

The ETH module is always in slave mode.

The NT311 ETH control unit is in communication with the network only when it is in temperature reading mode, while it is inactive when in the following modes: display, programming and test relays.

NOTES ON ETHERNET ELECTRICAL CONNECTIONS

As to the signal cable to use in order to guarantee correct operation, it is necessary to use a CAT 7 Ethernet cable with RJ45 connector with the following specifications:

- 4 twisted pairs 23AWG
- Tinned copper braid with an 80% cover.
- Always position the Ethernet cable far away from power cables.

FUNCTION CODE

The ModBus module supports the following function codes:

3₍₁₀₎: - holding register reading

16₍₁₀₎: - multiple registers writing

If ModBus receives a message and a CRC error is detected, no answer is given.

CODE 3₍₁₀₎.

Request:

Slave address, code 3₍₁₀₎, Starting address HI, Starting address LO, Number of Point HI, Number of Point LO, Crc LO, Crc HI.

Response:

Slave address, code 3₍₁₀₎, Byte count, Data HI, Data LO., Crc LO, Crc HI.

CODE 16₍₁₀₎.

Request:

Slave address, code 16₍₁₀₎, Starting address HI, Starting address LO, Number of Point HI, Number of Point LO, Byte count, Data HI, Data LO....., Crc LO, Crc HI.

Response:

Slave address, code 16₍₁₀₎, Starting address HI, Starting address LO, Number of Register HI, Number of register LO, Crc LO, Crc HI.

NOTES FOR REMOTE PROGRAMMING

The writeable registers are shown in TABLE MODBUS MAPPING referred to as W or RW (**write or read/write**). max number of registers 56, see table page 21.

In the case in which a parameter is not enabled and / or the information is not provided we have the following answers:

1. **Measured value** = 0000
2. **Value AL** = Value written in E2PROM
3. **Channel status** = 0000
4. **Channel setting** = %00000000; %xxxxxxx0 (x=n.d.)

In case you try to set these thresholds incorrectly, the control unit NT311 D will not proceed with the programming and storage of data, therefore in subsequent readings will read the data from the previous schedule.

After having sent a request for writing the control unit will take a time of about 1 " to store the data in eeprom, during the step of storing the module ModBus will not be able to process additional requests.

If the demand for programming is successful, the unit automatically resets and loads the new values set.

Note_1: HUMIDITY commands from ModBus - Simultaneous programming of both actuators is not permitted; in this case the default value is stored.

In the event that information is sent in writing to a register can't be written (only READ) data will be trashed without affecting the received message.

The information "RELAY STATUS" indicates the state of excitation of the coils of the relays, so it will be subject to the commands of "FAIL SAFE".

At the end of the write command (Write) is carried out a check of compatibility data:

1. **If you have a non-compatibility "exception" for an answer and the data packet is rejected in its entirety. The code of the first erroneous data can be obtained by reading the log "Error received data". (NB: this code is lost during RESET or new power or writing data in E2PROM);**
2. **If the data are correct, they are transferred to the non-volatile memory (E2PROM), the historical data is reset and a reset of the system is subsequently forced**
3. **If the WRITE command implies only writing "COMMANDS" it will be implemented autonomously and without RESET, i.e. without affecting the data of the control unit.**

ERROR CODES (exception codes)

In case of a wrong request, ModBus will answer with modified codes and codified errors according to the following:

- 1: - Unsupported function code
- 2: - Wrong data address
- 3: - Wrong data (for instance length)

In the event that all the relays: ALARM - FAN - HEATER are disabled the relay test will not take place.

ILLEGAL DATA

On the other hand, some combinations are programming errors because they are wrong settings; in this case the error code is ILLEGAL_DATA, This information is accessible to ModBus reading the register 7.

NO ERROR	No error 00
THi (HIGH) temperature programming out of range (10°C/60°C)	Code error 01
Tlo temperature programming. (LOW) out of range (-25°C / 10°C)	Code error 02
Humidity programming out of range (10% rH / 90% rH)	Code error 03
Dust programming out of range (10-25)	Code error 04
Data structure error BIT 0-6 (DATA) BIT 7-15 (SIGN)	Code error 05

Note; in case the values programmed from ModBus are out of range, a date "exception" error response will be generated.

MODBUS MAPPING TABLE

HEADER (information and commands):

Address LO (10)	Data HI	Data LO	R: read W:write RW: read/write
1	Model – MSD (ASCII)	Model - 3° Digit (ASCII)	R
2	Model - 2° Digit (ASCII)	Model – LSD (ASCII)	R
3	Space (20H)	Vers. Fw – MSD(ASCII)	R
4	Vers. Fw - 2° Digit (ASCII)	Vers. Fw – LSD(ASCII)	R
5	00		00
6	00	00	-
7	00	Incorrect datum received	R-see tab.
8	00	Info various causes	R-see tab.
9	00	Controls	W-see tab.

SYSTEM: Setting and Status

Address LO (10)	Data HI	Data LO	Notes 1	Notes 2	R: read W:write RW: read/write
10	00	00			-
11	00	00			-
12	00	00			-
13	00	CPU Setting	See Note		RW
14	00	CPU Error	See Note		R
15	00	Relays Status	See Note		R
16	00	00	--		R

Address LO (10)	Data HI	Data LO	Notes 1	Notes 2	W: write W:write W: read/write
17	00	Address	Modbus address	1255	R
18	00	Bdr	Modbus baud rate	0=2400 1=4800 2=9600 3=19200 4=38400	R
19	00	Parity	Modbus parity bit + Stop	0=No+1stop 1=Even 2=Odd 3=No+2stop	R
20	00	00			-
21	00	00			-
22	00	Sensor status	See Note		R
23	00	00	00		
24	00	00	00		
25	00	00	00		
26	00	00	00		
27	00	00	00		
28	00	00	00		
29	00	00	00		

Address LO (10)	Data HI	Data LO	Notes 1	Notes 2	W: write W: write W: read/write
30	00	2'compl temper_1 measured	MSB=sign	--	R
31	00	2'compl. temper_1 max set point	See Progr. Temp.THi	MSB=Sign	RW
32	00	Commands temper_1 max	--	--	RW
33	00	2'compl. temper_1 measured max (historical from E2PROM)	MSB=Sign	ModBus only	R
34	00	00	--	--	--
35	00	2'compl. temper. 2 min set point	See Progr. Temp.TLo	MSB=Sign	RW
36	00	Temperature controls 2 min	--	--	RW
37	00	2'compl. temper. 2 measured min (historic from E2PROM)	MSB=Sign	ModBus only	R
38	00	Measured humidity value	MSB=Sign	--	R
39	00	Max humidity Set point	See Progr. Humid.rH	--	RW
40	00	Humidity controls	See Note 1	--	RW
41	00	Max measured humidity (historic from E2PROM)	MSB=Sign	ModBus only	R
42	00	Dust level measured	MSB=Sign	--	R
43	00	Dust – set point	See Progr. Dust dSt	--	RW
44	00	Dust controls	--	--	RW
45	00	00	--	--	--
46	00	Digital Input 1	Bit_0: 1=ON	--	R
47	00	Digital Input Controls 1	--	--	RW
48	00	Digital Input 2	Bit_0: 1=ON	--	R
49	00	Digital Input Controls 2	--	--	RW
50	00	00	00		
51	00	00	00		
52	00	00	00		
53	00	00	00		
54	00	00	00		
55	00	00	00		
56	00	00	00		

REGISTERS NOTES

INFO various causes (Read)

BIT 7	BIT 6	BIT 5	BIT 4	BIT 3	BIT 2	BIT 1	BIT 0
--	--	--	--	--	--	--	RESET has taken place

COMMANDS (Write)

BIT 7	BIT 6	BIT 5	BIT 4	BIT 3	BIT 2	BIT 1	BIT 0
--	--	--	--	--	Reset Reg. CPU_Error	Reset historical data	Reset BIT: RESET has taken place

RELAY STATUS (coil energising status)

BIT 7	BIT 6	BIT 5	BIT 4	BIT 3	BIT 2	BIT 1	BIT 0
--	--	--	FAULT Relay 1=No Fault	--	Relay ALARMS 1=ON	Relay Actuator_2 1=ON	Relay Actuator_1 1=ON

CPU SETTING

BIT 7	BIT 6	BIT 5	BIT 4	BIT 3	BIT 2	BIT 1	BIT 0
--	--	--	Failsafe fault	--	--	--	--

CPU ERROR

BIT 7	BIT 6	BIT 5	BIT 4	BIT 3	BIT 2	BIT 1	BIT 0
--	--	--	Tecsybus Error TEC	Sens. Dust Error dSt	Sens. Humid. Error rH	Temp Sens. Error °C	ECH error

SENSOR STATUS

BIT 7	BIT 6	BIT 5	BIT 4	BIT 3	BIT 2	BIT 1	BIT 0
--	--	In P. D2 = All	In P. D1 = All	Dust=All	Humidity=All	Temp_2=All	Temp_1=All

TEMPERATURE CONTROLS 1 - MAX

BIT 7	BIT 6	BIT 5	BIT 4	BIT 3	BIT 2	BIT 1	BIT 0
--	--	--	--	Enabl. Alarm	--	Enabl. FAN	Enabl. Measurement

TEMPERATURE CONTROLS 2 - MIN

BIT 7	BIT 6	BIT 5	BIT 4	BIT 3	BIT 2	BIT 1	BIT 0
--	--	--	--	Enabl. Alarm	Enabl. HEATER		Enabl. Measurement

HUMIDITY COMMANDS

BIT 7	BIT 6	BIT 5	BIT 4	BIT 3	BIT 2	BIT 1	BIT 0
--	--	--	--	Enabl. Alarm	Enabl. HEATER	Enabl. FAN	Enabl. Measurement

DUST CONTROLS

BIT 7	BIT 6	BIT 5	BIT 4	BIT 3	BIT 2	BIT 1	BIT 0
--	--	--	--	Enabl. Alarm	--	--	Enabl. Measurement

DIGITAL INPUT CONTROLS (1; 2)

BIT 7	BIT 6	BIT 5	BIT 4	BIT 3	BIT 2	BIT 1	BIT 0
--	--	--	--	Enabl. Alarm	--	--	Enabl. Sensor

ETHERNET MODULE PROGRAMMING PARAMETER

X Windows Vista, 7, 8.

ETH0 CONNECTIONS

Using an Ethernet cable, connect the ETH0 RJ45 of the NT311 ETH control unit to the Ethernet card of a PC.

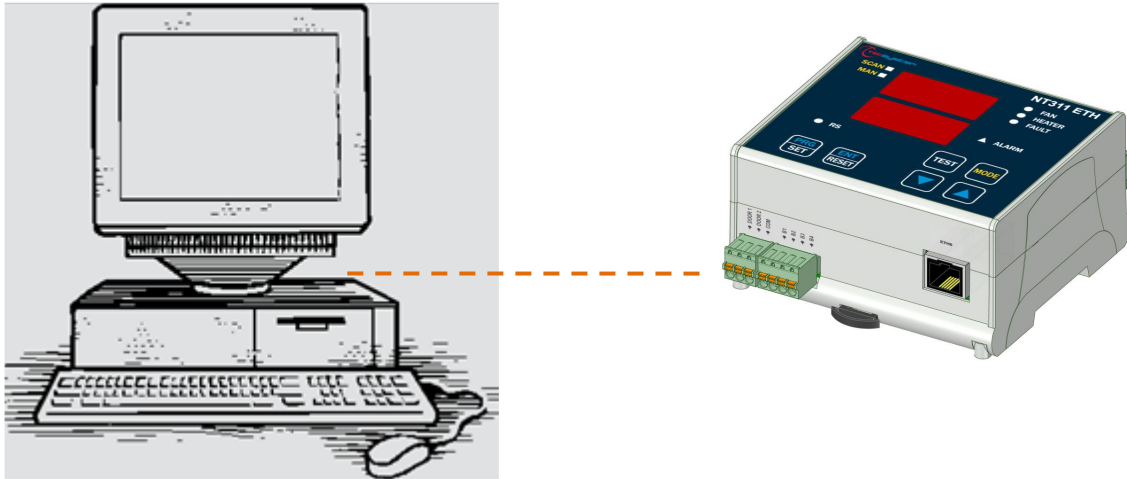

TELNET ENABLING

Use the Telnet program to set the Ethernet IP parameters.

1) START menu (Windows)

If already enabled, the program appears

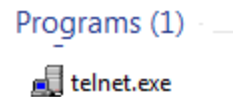

2) Start the search with the Telnet program
Entering telnet in SEARCH.

Press ENTER to launch the program.

If the Telnet program is not enabled:

[\(Jump to step 12 page 26\)](#)

3) START menu (Windows):

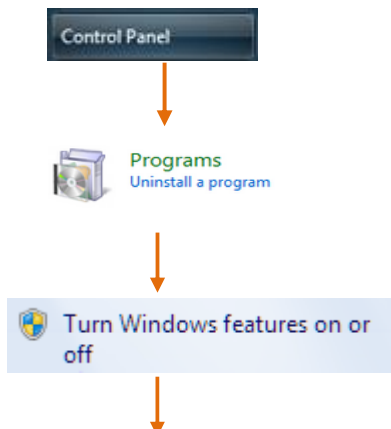

5) Select Control Panel

(Go to step 12 on page 28)

4) Select Control panel

7) Enable Telnet Client and click "OK"

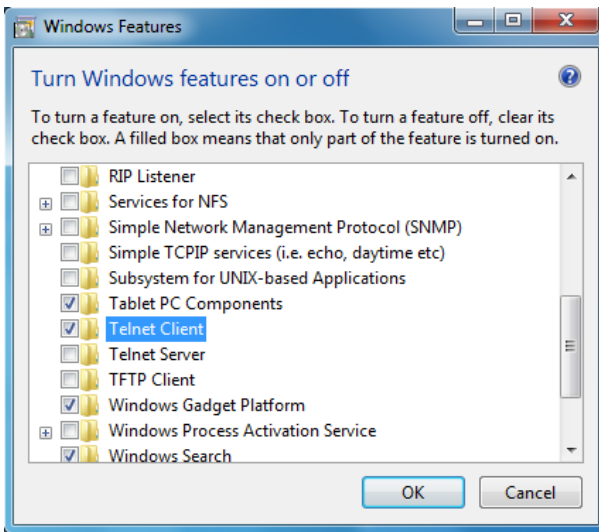

**The screen below will open.
Wait for the Telnet function to activate.**

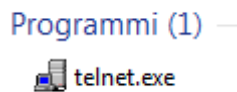
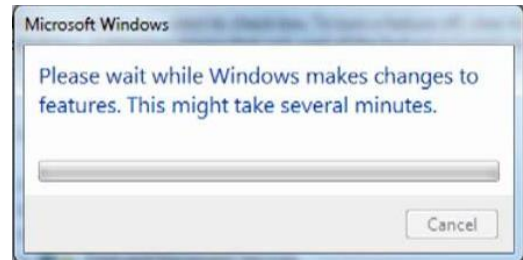

8) Close the open screens and restart the PC if required

9) START menu (Windows)

10) Search for the Telnet program

11) Press ENTER to launch the program

12) TELNET SCREEN

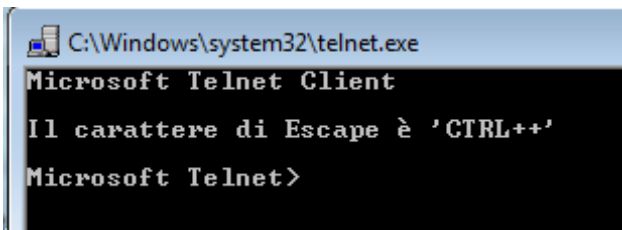

13) Enter: OPEN

14) Press ENTER

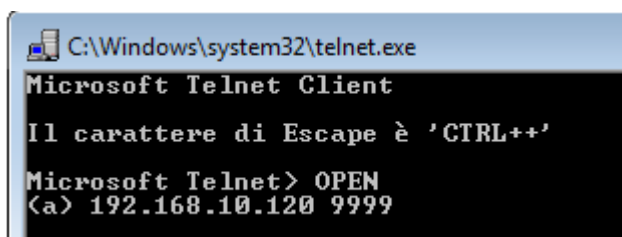

15) Enter: 192.168.10.120 9999

16) Press ENTER

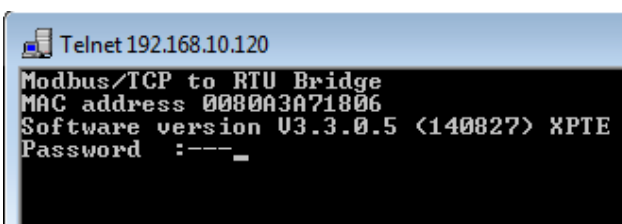

17) Enter the Password: TECS

18) Press ENTER

Note: In this screen we have the **MAC address** and the **software** version of the ETH port available.

19) IP PARAMETER PROGRAMMING MENU

```
Telnet 192.168.10.120
Modbus/TCP to RTU Bridge
MAC address 0080A3A71806
Software version U3.3.0.5 (140827) XPTE
Password :----
Press Enter for Setup Mode

Model: Device Server Plus+! (Firmware Code:YM)

Modbus/TCP to RTU Bridge Setup
1) Network/IP Settings:
   IP Address ..... 192.168.10.120
   Default Gateway ..... 192.168.10.1
   Netmask ..... 255.255.255.0
   Telnet config password set
2) Serial & Mode Settings:
   Protocol ..... Modbus/RTU,Slave(s) attached
   Serial Interface ..... 19200,8,E,1,RS485
3) Modem/Configurable Pin Settings:
   CP1 ..... RS485 Output Enable
   CP2 ..... Not Used
   CP3 ..... Not Used
4) Advanced Modbus Protocol settings:
   Slave Addr/Unit Id Source .. Modbus/TCP header
   Modbus Serial Broadcasts ... Disabled (Id=0 auto-mapped to 1)
   MB/TCP Exception Codes .... Yes (return 00AH and 00BH)
   Char. Message Timeout ..... 00050msec, 05000msec
7) Security Settings:
   SNMP ..... Enabled
   SNMP Community Name ..... public
   Telnet Setup ..... Enabled
   TFTP Download ..... Enabled
   Port 77FEh ..... Enabled
   Web Server ..... Enabled
   Enhanced Password ..... Disabled
   Port 77F0h ..... Enabled

D)efault settings, S)ave, Q)uit without save
Select Command or parameter set (1..7) to change: _
```

IP PARAMETER PROGRAMMING MENU (TELNET)

The TELNET menu allows you to modify the configuration parameters of the Ethernet port.

The information available to you is:

Parameters that can be modified by the operator

- 1) Parameter modification (IP Address - Gateway- Netmask -Telnet password).

Parameters that cannot be modified by the operator

- 2) Communication parameters between the ETH0 port and the control unit.
- 3) Communication configuration between the ETH0 port and the control unit.
- 4) Communication advanced settings between the ETH0 port and the control unit.
- 7) Security settings between the ETH0 port and the control unit.



IMPORTANT INFORMATION

For a correct operation of the device it is advised not to access or modify menus 2-3-4-7. Changing the values contained in the indicated menus could lead to communication anomalies with loss of IP Ethernet communication.

MENU MODIFICATION PROCEDURE 1) IP parameters:

enter the command: 1

```
IP Address: IP Address <192> 192.<168> 168.<010> .<120> 120_
```

1) Enter the desired new IP address, if you wish to keep the set address press ENTER 4 times.

- At the end of the operation, the system will ask if you wish to modify the Gateway IP:

```
IP Address <192> 192.<168> 168.<010> .<120> 120  
Set Gateway IP Address <N> ?
```

Type in: **Y** to modify the Gateway IP.

N not to modify the Gateway IP and go to the following step.

2) Enter the desired new Gateway IP address, press ENTER; if you wish to keep the set address press ENTER 4 times.

```
IP Address <192> 192.<168> 168.<010> .<120> 120  
Set Gateway IP Address <N> ? Y  
Gateway IP Address : <192> 192.<168> 168.<010> 10.<001> 001_
```

- At the end of the operation, the system will ask if you wish to modify Netmask:

```
IP Address <192> 192.<168> 168.<010> .<120> 120  
Set Gateway IP Address <N> ? Y  
Gateway IP Address : <192> 192.<168> 168.<010> 10.<001> 001  
Set Netmask <N for default> <N> ?
```

Type in: **Y** to modify the Netmask.

N not to modify Netmask and go to the following step.

3) Enter the new Netmask, press ENTER; if you wish to keep the set address press ENTER 4 times.

```
IP Address <192> 192.<168> 168.<010> .<120> 120  
Set Gateway IP Address <N> ? Y  
Gateway IP Address : <192> 192.<168> 168.<010> 10.<001> 001  
Set Netmask <N for default> <N> ? Y  
<255> .<255> .<255> .<000> _
```

- At the end of the operation, the system will ask if you wish to modify the Telnet Password:

```
IP Address <192> 192.<168> 168.<010> .<120> 120  
Set Gateway IP Address <N> ? Y  
Gateway IP Address : <192> 192.<168> 168.<010> 10.<001> 001  
Set Netmask <N for default> <N> ? Y  
<255> .<255> .<255> .<000>  
Change telnet config password <N> ? _
```

Type in: **Y** to modify the Telnet Password.

N not to modify the Telnet Password and go to the following step.

```

IP Address <192> 192.<168> 168.<010> .<120> 120
Set Gateway IP Address <N> ? Y
Gateway IP Address : <192> 192.<168> 168.<010> 10.<001> 001
Set Netmask <N for default> <N> ? Y
<255> .<255> .<255> .<000>
Change telnet config password <N> ? Y
Enter new Password:

```

4) Enter the new Telnet Password (4 digits max), press ENTER; if you wish to keep the set Password, press ENTER.

```

D>default settings, S>ave, Q>uit without save
Select Command or parameter set <1..7> to change: _

```

Type in: S to save the modified data.

Q to exit Telnet without saving the data.

The following screen will be displayed:

```

D>default settings, S>ave, Q>uit without save
Select Command or parameter set <1..7> to change:
Parameters saved, Restarting ...
Connessione all'host perduta.
Premere un tasto per continuare..._

```

To check the programmed parameters or repeat programming, follow the TELNET SCREEN from step 12 to step 19, page 27.

Indications of LEDs 1-2 of the Ethernet port:

LED 1: Link

- > Off = No link
- > Amber = 10 Mbps
- > Green = 100 Mbps

LED 2: Activity

- > Off = No Activity
- > Amber = Half Duplex
- > Green = Full Duplex



WARRANTY REGULATIONS

The purchased Product is covered by the manufacturer's or seller's warranty under the terms and conditions indicated in the "Tecsystem s.r.l. General Sales Conditions", which can be consulted on the website www.tecsystem.it and/or in the stipulated purchase contract.

The warranty is considered valid only when the product is damaged by causes attributable to TECSYSTEM srl, such as manufacturing or components defects.

The warranty is invalid if the Product proves to have been tampered with/modified or incorrectly connected and causing voltages outside the set limits and does not comply with the technical data for use and assembly, as described in this instruction manual.

The warranty is always ex Corsico as stated in the "General Conditions of Sale".

TROUBLESHOOTING	CAUSES AND SOLUTIONS
The control unit does not switch on and the supply to terminals 40-42 is correct.	Check that: the connector is firmly inserted in its place, the connection wires are tight and that there are no obvious signs of burns on the connectors. Turn off the power supply and carry out the above instructions, restore the voltage.
Fault with indication "ECH"	A strong disturbance has damaged the memory data. See the paragraph for programmed data diagnostics on page 16.
Fault with TEC indication	TPU sensor disconnected. It is advisable to check the connection between the sensor and the control unit.
Fault with indication FLT°C	Check the connections and if necessary replace the faulty sensor. In case the minimum/maximum full scale value has been reached, make sure that the environmental conditions correspond to what is indicated by the control unit.
Fault with dSt indication	Check the connections and if necessary replace the faulty sensor. In case the minimum/maximum full scale value has been reached, make sure that the environmental conditions correspond to what is indicated by the control unit.
Fault with indication rH	Check the connections and if necessary replace the faulty sensor. In case the minimum/maximum full scale value has been reached, make sure that the environmental conditions correspond to what is indicated by the control unit.
The control unit displays Door 1 or Door 2 door alarm but the doors are closed.	Check the engagement of the terminals and tightening of the screws on the Door1-Door2-Com inputs
Contact the <i>TECSYSTEM</i> Technical Department if the problem persists.	

EQUIPMENT DISPOSAL

The European directive 2012/19/EU (WEEE) has been approved to reduce the waste of electrical and electronic appliances and to encourage the recycling and reuse of materials and components of these appliances, thereby reducing the disposal of harmful residues and compounds originating from electrical and electronic material.



All the electrical and electronic equipment supplied after 13 August 2005 is marked with this symbol, pursuant to European directive 2012/19/EU on electrical and electronic waste (WEEE). Any electrical or electronic equipment marked with this symbol must be disposed of separately from normal domestic waste.

Returning of used electrical appliances: contact TECSYSTEM or the TECSYSTEM agent to receive information on correct disposal of the appliances.

TECSYSTEM is aware of the impact its products have on the environment and asks its customers active support in the correct and environmentally-friendly disposal of its devices.

USEFUL CONTACTS

TECHNICAL INFORMATION: ufficiotecnico@tecsystem.it

SALES INFORMATION: info@tecsystem.it

