

INSTRUCTION MANUAL

VRT600

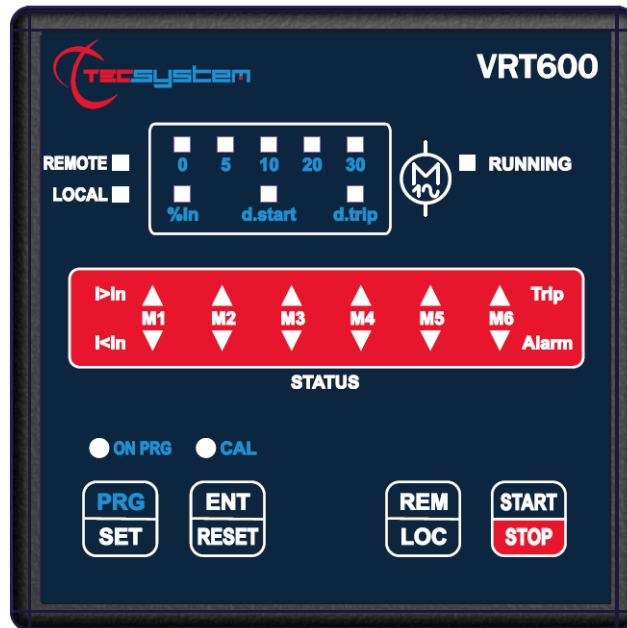

1MN0050 REV. 3



operates with ISO9001 certified quality system

TECSYSTEM S.r.l.
20094 Corsico (MI)
Tel.: +39-024581861
Fax: +39-0248600783

<http://www.tecsystem.it>

R. 1.9 26/11/20

ENGLISH

“Translations of the original instructions”

INTRODUCTION

First of all we wish to thank you for choosing to use a **TECSYSTEM** product and recommend you read this instruction manual carefully: You will understand the use of the equipment and therefore be able to take advantage of all its functions.

ATTENTION! THIS MANUAL IS VALID AND COMPLETE FOR THE UNIT VRT600 ED18

CONTENTS

	PAGE
1) SAFETY REQUIREMENTS	3
2) ACCESSORIES	4
3) TECHNICAL SPECIFICATIONS	5
4) FRONT PANEL	7
5) MOUNTING	8
6) ELECTRICAL CONNECTIONS	9
• VRT600 BACK	—
• POWER SUPPLY	10
• OPERATION	—
• HOW TO CHECK THE ALARM STATUS	—
7) PROGRAMMING	11
8) WARRANTY CONDITIONS	12
9) TROUBLESHOOTING	—
10) EQUIPMENT DISPOSAL	—
11) USEFUL CONTACTS	13

SAFETY REQUIREMENTS



ATTENTION:

Read the manual carefully before starting to use the control unit. Keep the instructions for future reference.



Do not open the device, touching any internal components can cause electric shock. Contact over 50 Volts AC can be fatal. To reduce the risk of electric shock, do not dismantle the back of the device for any reason. Moreover its opening would void the warranty.

Before connecting the device to the power supply, make sure that all the connections are correct. Always disconnect the unit from the supply before any cabling modification.



Any intervention on the equipment must be entrusted to a qualified repair engineer

Failure to comply with these instructions can cause damages, fires or electric shock, and possible serious injuries!

POWER SUPPLY

The VRT600 can be supplied by 85-250Vac 50/60Hz.

Before using it, make sure the power cable is not damaged, kinked or pinched. Do not tamper with the power cable. Never disconnect the unit by pulling the cable, avoid touching the pins. Do not carry out any connecting/disconnecting with wet hands. To disconnect the device, do not use objects such as levers. Immediately disconnect the device if you smell burning or see any smoke: contact technical service.

LIQUIDS

Do not expose the equipment to splashes or drops, do not position it in places with humidity exceeding 90% and never touch with wet or humid hands. If any liquid penetrates the control unit, disconnect it immediately and contact technical service.

CLEANING

Disconnect the power cable before cleaning the control unit, use a dry cloth to dust it, without any solvent or detergents, and compressed air.

OBJECTS

Never insert any objects into the cracks of the control unit. If this happens, disconnect the control unit and contact an engineer.

USE RESERVED TO QUALIFIED PERSONNEL

The purchased goods are a sophisticated electronic device that is totally unsuitable to be used by non-qualified personnel. Any intervention must be carried out by a specialist engineer.

ACCESSORIES

The use of non-original accessories or spare parts might damage the unit and endanger users' safety. In the event of faults, contact technical service.

LOCATION

Install the control unit indoors, in a place protected from water splashes and sun rays. Do not place near heat sources exceeding the parameters stated in this manual. Position on a stable surface, far from any possible vibrations. Position the unit as far as possible from any intense magnetic fields.

REPAIRS

Do not open the control unit. For any fault, always use qualified personnel. The opening of the control unit and/or the removal of the series identifying label entails the automatic forfeiture of the warranty. The Warranty seal is applied to all devices, any attempt to open the unit would break the seal and cause the consequent automatic forfeiture of the warranty.

TECHNICAL INFORMATION

Mail: ufficiotecnico@tecsystem.it — tel: 02/4581861

ACCESSORIES

The following objects are present inside the box:

Control unit



Start guide and QR CODE



2 blocks for panel mounting

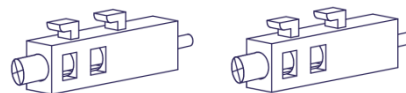

1 ENABLE and FAULT relay contact terminal 5 poles pitch 5
Code: 2PL0371 - Screws tightening torque 0.5Nm



1 supply terminal 3 poles pitch 5 Code: 2PL0367
Screws tightening torque 0.5Nm



2 Motor line terminals 6 poles pitch 5 Code: 2PL0372
Screws tightening torque 0.5Nm



1MN0030 REV. 2

ATTENTION: always install the device using the terminals included in the pack. The use of terminals other than those included with the control unit might cause malfunctions.

TECHNICAL SPECIFICATIONS	VRT600
POWER SUPPLY	
Supply rated values	85-250 Vac 50/60 Hz
INPUTS	
1 contact enabling remote control (ENABLE)	•
2 motor line supply inputs 15 A max	85-250Vac 50/60Hz.
Connections on removable terminal strips	•
OUTPUTS	
1 fault sensor or operating failure (FAULT) relay SPDT	•
Output relay with 5A-250Vac-res $\text{COS}\Phi=1$ contacts.	•
6 outputs M1-M2-M3-M4-M5-M6 : 5A max	85-250Vac 50/60Hz.
DIMENSIONS	
100x100 mm– din43700-depth 131mm (terminal block included)	Hole 92 x 92 mm
TEST AND PERFORMANCE	
Construction in compliance with CE regulations	•
Protection from electrical interference EN 61000-4-4	•

TECHNICAL SPECIFICATIONS

VRT600

TEST AND PERFORMANCE

Dielectric strength 1500 Vac for 1 minute: supply - relay fault, supply - remote.

•

Ambient operating temperature from -20°C to +60°C

•

Humidity 90% non-condensing

•

Housing NORYL 94_V0

•

Absorption 7.5VA (max)

•

Protection treatment of the electronic part

Option

Front film polycarbonate IP65

•

DISPLAY AND DATA MANAGEMENT

LED's alarm: undercurrent, overcurrent.

•

LED's running: remote, local

•

LED's prg setting, cal.

•

Initial AUTO-TUNING to set up motors' operation

•

Front button to START/STOP motors locally

•

Front alarm RESET button

•

Access to programming through front button

•



IMPORTANT WARNING

Before carrying out the isolation test of the electrical panel the control unit is installed on, disconnect M1-M2-M3-M4-M5-M6 outputs and the power supply, to prevent it from being seriously damaged.

FRONT PANEL

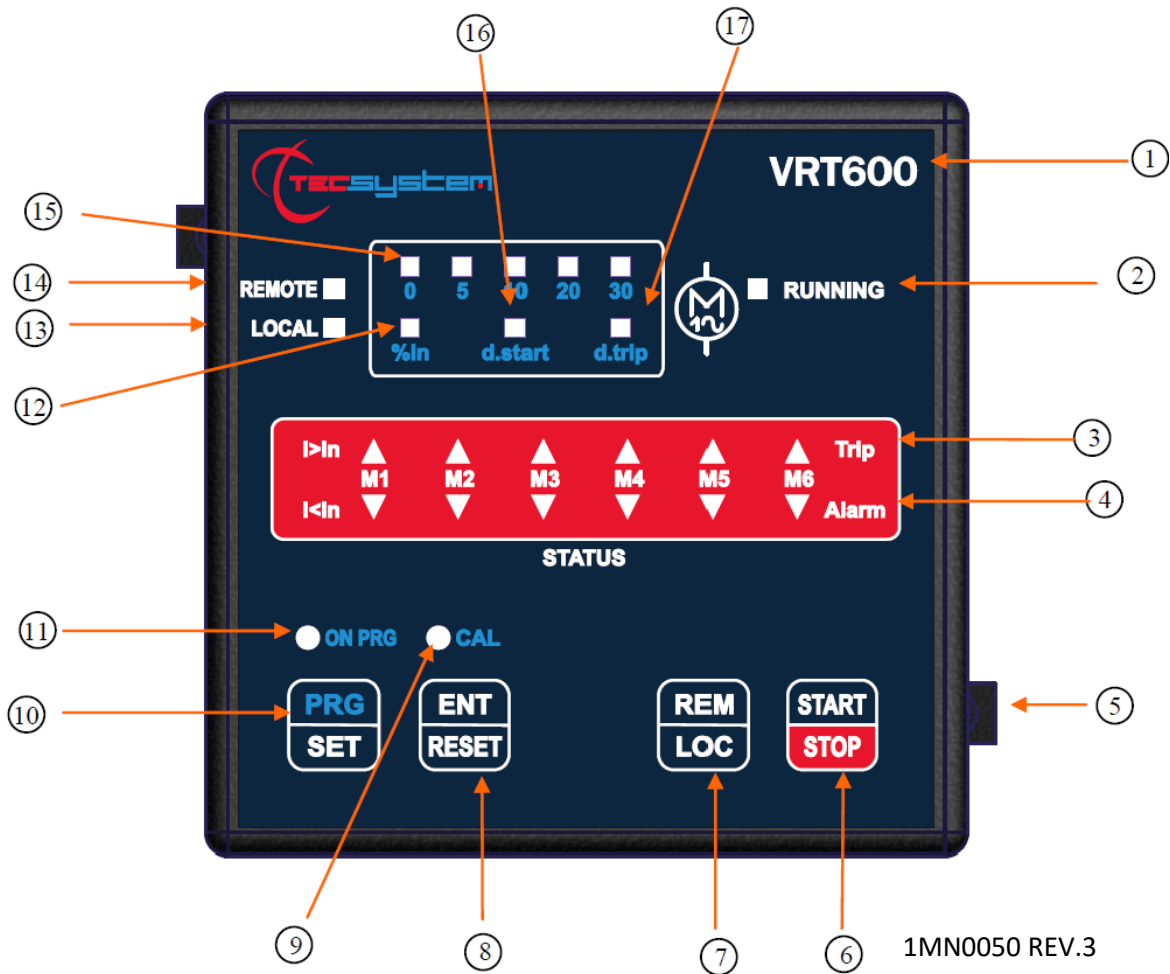

1MN0050 REV.3

1)	Control unit series	10)	PRG/SET button: entering programming and going on to the following step
2)	Active (running) ventilation LED (green)	11)	Programming phase ON PRG LED (yellow)
3)	LED (red) warning motors M1-M2-M3-M4-M5-M6 are in over-current	12)	Current variation LED (yellow)
4)	LED (yellow) warning motors M1-M2-M3-M4-M5-M6 are in under-current	13)	Fans' local management LED (yellow)
5)	Fixing block	14)	Fans' remote control LED (green)
6)	Fans' local START/STOP button	15)	Programming selection LED (yellow) (% In, d.start, d.trip)
7)	Fans' control mode REM/LOC button (REMOTE or LOCAL)	16)	Monitoring delay LED (yellow) at start up d.start
8)	ENT/RESET button: alarm reset and programming data selection	17)	Release delay LED (yellow) d.trip
9)	Motors' auto-tuning phase LED (yellow)		

MOUNTING

Drill a 92 x 92 mm hole in the panel sheet.

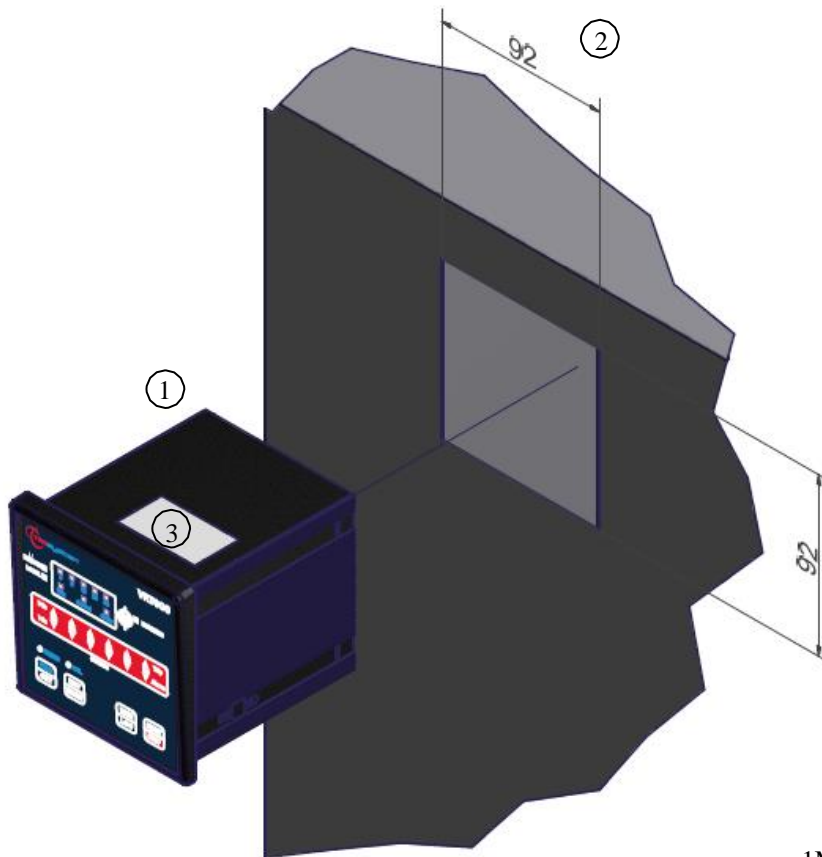

1MN0063 REV. 2

1)	Control unit	2)	Panel hole dimensions (+0.8mm tolerance)
3)	Identification label		

Fix the unit securely with the blocks supplied.

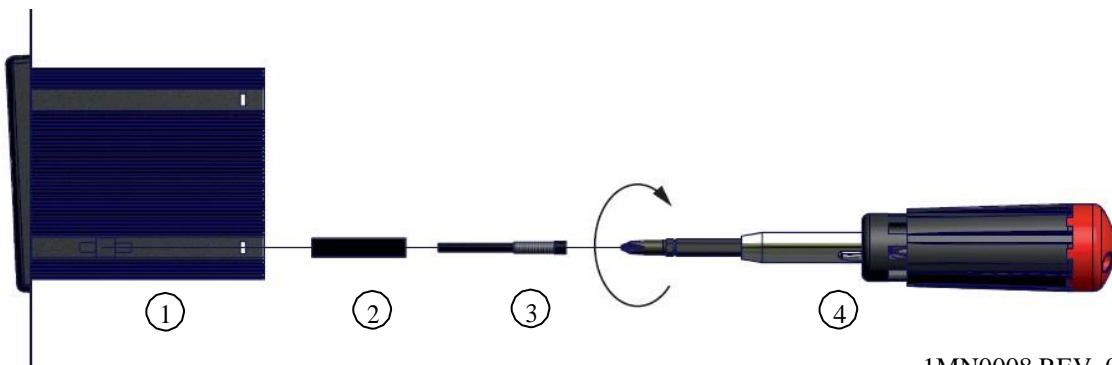

1MN0008 REV. 0

1)	Control unit	3)	Fixing screw
2)	Fixing block	4)	Crosshead screwdriver #1X100mm

ELECTRICAL CONNECTIONS

VRT600 ED18

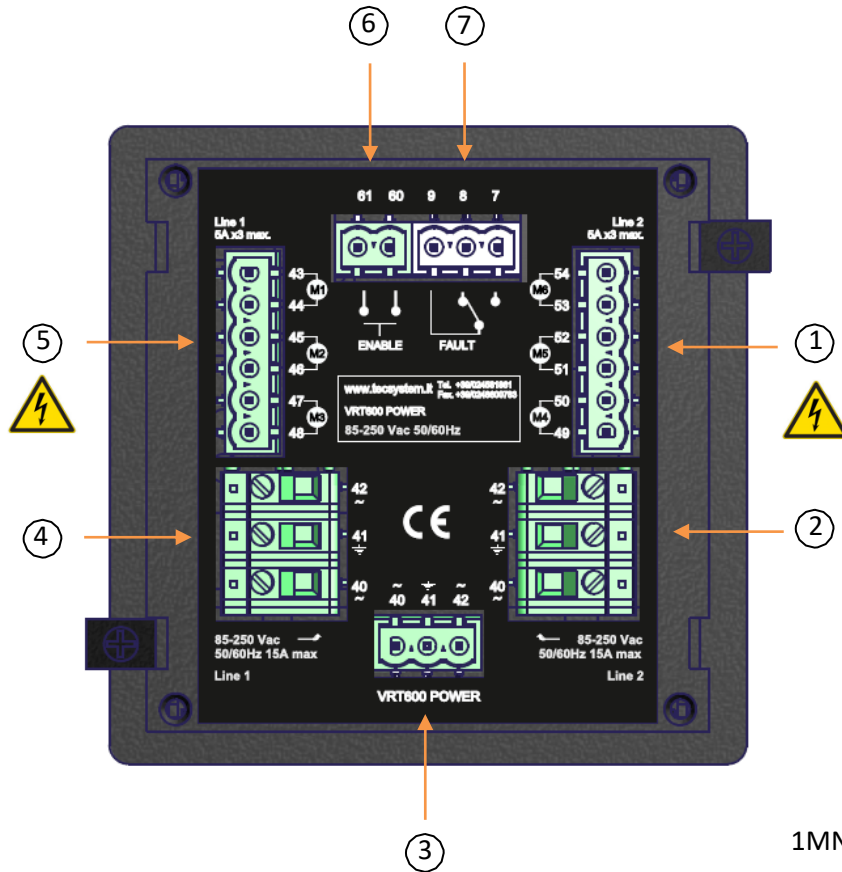

1MN0050 REV.3

1)	M4-M5-M6 motor line connection (5A max) OUTPUT POWERED	5)	M1-M2-M3 motor line connection (5A max) OUTPUT POWERED
2)	M4-M5-M6 fan line supply 85-250Vac 15 Amp.max 50-60Hz.	6)	Remote enabling contact ENABLE
3)	Control unit supply 85-250 Vac 50-60 Hz 7.5 VA	7)	FAULT relay (fault signal)
4)	M1-M2-M3 fan line supply 85-250Vac 15 Amp.max 50-60Hz.		

Note: with the power to the unit ON, the FAULT relay switches, contacts 8-9 open (NO) and 7-9 closed (NC).

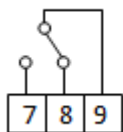

FAULT 8-9 NC: ALARM FAULT OR POWER OFF

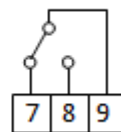

FAULT 7-9: NC POWER NO FAUL

POWER SUPPLY

The VRT600 control unit must be supplied with 85-250Vac 50/60Hz.

A variation in the network voltage of over 10% might cause alarms because of the current variation in the load.

If the electrical system is affected by harmonic frequencies, alarm warnings might be triggered because of the consequent variation in the current absorbed by the motors.

It is good practice to make sure that the level of system harmonics is not such as to cause malfunction or damages to all the connected electrical and electronic instruments, in compliance with the regulations in force for the type of system.

When the control unit is powered directly by the secondary of the transformer to be protected, it can be burnt out by high intensity overvoltages.

These problems occur if the main switch is closed and the transformer does not have the load (no load test).

The above is much more evident when the 220 Vac voltage is taken directly from the bars of the secondary of the transformer and there is a fixed capacitor battery for power factor correction of the transformer itself.

OPERATION

When switched on, the device carries out a LAMP TEST and is set either in REMOTE or LOCAL mode, according to how it was set before being switched off.

In REMOTE mode the fans are activated when contact 60-61 closes, which must be connected to the FAN contact of the temperature control unit.

In LOCAL mode the fans are activated by pressing the <START-STOP> button. The status of operation is stored in case of power failure.

HOW TO CHECK THE ALARM STATUS

- **Running LED OFF:** no ventilation activation control
- **Running LED ON:** REMOTE or LOCAL ventilation activation
- **Over- and under-current LEDs OFF:** motor operating correctly
- **Over-current LED ON:** motor stopped due to over-current
- **Under-current LED ON:** motor working + under-current alarm signal
- **Under-current LED flashing:** motor disconnected while auto-tuning
- **Over-current LED ON:** motor consumption >5.5A (immediate trip without any delay)
- **All LEDs flashing:** corrupted memory error (ech); press reset and repeat the programming procedure

N.B.: A motor in a state of alarm or the interruption of supply to the device make contacts 8-9 of the FAULT relay close.

HOW TO RESET A MOTOR IN ALARM

To reset an alarm due to under-current or over-current, press the RESET button after carrying out the necessary checks and any repairs might be required.

OPERATION WITH FANS NOT TECSYSTEM









The proper functioning of the VRT unit is guaranteed only for: fans with current absorption between 250mA (IN MAX 20%) or 300mA (IN MAX 30%) and 5A, single phase, single speed and power variation is not greater than $\pm 10\%$.



IMPORTANT NOTE: if an existing control unit must be replaced with a new one, to guarantee its correct and safe operation, all the connecting terminals must be replaced with the new terminals supplied, on condition the brand of the new terminals is different from the one of the previously installed ones

PROGRAMMING

VRT600

STEP	PRESS	EFFECT	PRESS	NOTES
1		Programming start		Keep pressing for 5 seconds until the ON PRG LED switches ON.
2		Programming "%In"		Set the maximum current variation allowed as a percentage (5-10-20-30%) of the In. rated value. Default 5%
3		Going to the "d.start" programming step		Start delay: fan start time during which no alarm is generated
4		Selection of the time in seconds "d.start"		Select the desired time (5-10-20-30 sec.) Default 5
5		Going to the "d.trip" programming step		Trip delay: time during which the alarm persists, necessary for signalling
6		Selection of the time in seconds "d.trip"		Select the desired time (5-10-20-30 sec.) Default 5
7		Motor start for automatic calibration CAL LED ON 		To perform the "automatic calibration" all motors must be connected as per final configuration. At the START the motors are switched ON for 60 seconds, the CAL LED flashes and LEDs 0-5-10-20-30 light up in sequence. When the calibration is completed, the control unit resets and goes into REMOTE mode

N.B.: any connection or programming errors might cause fan malfunctions.



ATTENTION:

We recommend you check the control unit before starting the device.

The default parameters set by TECSYSTEM might not suit your requirements.

Programming the device is the end user's responsibility: the set alarm thresholds and the enabled functions described in this manual must be checked (by a specialized technician) referring them to the application and system characteristics on which the control unit is installed.

WARRANTY CONDITIONS

The Product purchased is covered by the manufacturer's or seller's warranty at the terms and conditions set forth in the "Tecsystem s.r.l.'s General Conditions of Sale", available at www.tecsystem.it and / or in the purchase agreement.

The warranty is considered valid only when the product is damaged by causes attributable to TECSYSTEM srl, such as manufacturing or components defects.

The warranty is invalid if the Product proves to have been tampered with / modified, incorrectly connected, because of voltages outside the limits, non-compliance with the assembly and use technical data, as described in this instruction manual.

The warranty is always ex Corsico as stated in the "General Conditions of Sale".

TROUBLESHOOTING	CAUSES AND SOLUTIONS
The control unit does not switch on and the supply to terminals 40-42 is correct.	Check that: the connector is correctly inserted into its housing, the wires are tightened, there is no evidence of burning on the connectors. Disconnect the power supply, carry out the above and reconnect.
M1-M2-M3-M4-M5-M6 over-current red LED ON	Check the condition of the fans and replace any faulty ones. Re-program the device.
M1-M2-M3-M4-M5-M6 under-current yellow LED ON	Check the condition of the fans, the cables and the supply. Re-program the device.
All the LEDs are flashing	Memory error, press RESET and repeat the programming procedure.
All the LEDs are ON	Likely microcontroller fault, return the device to Tecsystem for repair.
Contact TECSYSTEM Technical Department if the problem persists.	

EQUIPMENT DISPOSAL

European directive 2012/19/EU (WEEE) has been approved to reduce electrical and electronic waste and promote the recycling and reuse of the materials and components of this equipment, cutting down on the disposal of the residues and harmful components of electrical and electronic materials.



All the electrical and electronic equipment supplied after 13 August 2005 is marked with this symbol, pursuant to the European directive 2012/19/EU on electrical and electronic waste (WEEE). Any electrical or electronic equipment marked with this symbol must be disposed of separately from normal domestic waste.

Returning used electrical devices: contact TECSYSTEM or the TECSYSTEM agent for information on the correct disposal of the devices.

TECSYSTEM is aware of the impact its products have on the environment and asks its customers active support in the correct and environmentally-friendly disposal of its devices.

USEFUL CONTACTS

TECHNICAL INFORMATION: ufficiotecnico@tecsystem.it

SALES INFORMATION: info@tecsystem.it

