



# U27

**整机重量 : 2700 kg**

**Working weight: 2700 kg**

**斗容 : 0.09 m<sup>3</sup>**

**Bucket capacity: 0.09 m<sup>3</sup>**

[产品介绍](#)  
Product introduction

## 高端配置 High-end configuration

YC27SR是玉柴无尾挖掘机，机身小巧，配备国际品牌洋马发动机，负载敏感阀  
YC27SR is Yuchai tailless excavator with compact body, equipped with international brand engine and load sensitive valve.

## 先导操作 Pilot Operation

具备左右先导操作，动作柔和，稳定性更好  
维护便利，使用成本低  
With left and right pilot operation, it has gentle movement and better stability.  
Convenient maintenance and low use cost.

## 真正的无尾回转 True Tailless Gyration

整体机身不超出履带两侧的宽度，使得回转作业时不会阻碍挖掘机的回转。轻松面对狭窄地形的工况。  
The whole body does not exceed the width of both sides of the track, so that the slewing operation will not hinder the slewing of the excavator. Easy to face the narrow terrain.



# U27

## 玉柴重工2.7 ton无尾挖掘机

Yuchai Heavy Industry 2.7 ton tailless excavator

玉柴U27无尾挖掘机，机身更小、更快、运输过程更灵活

Yuchai U27 tailless excavator has smaller body, faster movement and more flexible transportation process.



# 玉柴小挖 YUCHAI Mini Excavator. 响彻世界的挖掘机品牌

The world's most famous excavator brand

玉柴重工成立于1989年，是中国最早生产微挖并销往全球的挖掘机企业，是中国国内最大的小型挖掘机生产、出口基地，国家级高新技术企业。  
三十多年创新发展，给客户高品质保证！

YUCHAI Heavy Industry Co. Ltd., founded in 1989, is the first enterprise of excavators in China to produce mini-excavators and sell them to the world. As China's largest state-level high-tech enterprise, it is also a producing and exporting base of small excavators.

More than 30 years of innovation and development to ensure high-quality customers!



## 出色的操作性能

### Excellent Operation Performance

工装装置复合动作协调、流畅；操控精准、手感柔和；行走有力、顺畅、无跳动；整机稳定、无点头翘尾现象；无冲击、无异响想象。

The compound action of the tooling is coordinated and smooth; Accurate control and soft touch; Walk powerfully, smoothly and without beating; The whole machine is stable, without nodding and cocking; No impact, no abnormal sound imagination.



## 洋马发动机 Yanmar Engine

功率/转速 (kW/rpm) : 14.5kW/2400rpm ; 自然吸气发动机 ; 最大扭矩/转速 (Nm/rpm) : 62.7~68.4Nm/1800rpm ; 发动机带消声器 ; 铝制, 油散、水散并联式散热器。

Power/speed (kW/rpm): 14.5 kW/2400 rpm; Naturally aspirated engine; Maximum torque/speed (nm/rpm): 62.7 ~ 68.4 nm/1800 rpm; With engine muffler; Aluminum, oil dispersion and water dispersion parallel radiator.

## 全先导操纵 Full Pilot Control

驾驶体验更舒适，挖掘机动作更流畅

The driving experience is more comfortable and the excavator action is more smooth



## 超强互换 Super Swap

二柱棚→四柱棚，实现驾驶棚与，驾驶室安装互换

Two columns → four columns shed.  
The cab switch is simple.

## 丰富属具 Rich in Attachments

十多类属具

液压锤、铲斗、快换装置、抓木器、简易抓钳

清沟斗、贝型斗、钻具、割草机等

应用四十多种重点工况，工况范围广

More than ten genera of fittings

Hydraulic hammer, bucket, quick change device,

wood grabber, simple grasping pliers, ditching

bucket, shell bucket, drilling tools, lawn mower, etc.

It is applied in more than 40 key working conditions.



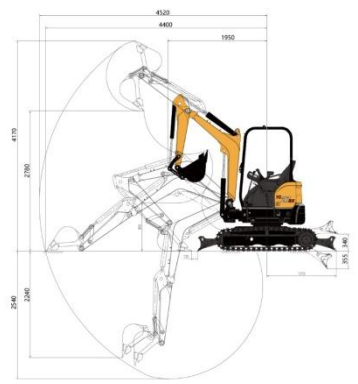

| 技术规格 Technical specifications                     | 参数 Parameter | 单位 Unit        |
|---|--------------|----------------|
| <b>基本参数</b><br>Basic parameter                    |              |                |
| 整机重量<br>Machine weight                            | 2700         | kg             |
| 标准斗容<br>Bucket capacity                           | 0.09         | m <sup>3</sup> |
| <b>性能参数</b><br>Performance parameter              |              |                |
| 发动机<br>Engine model                               | 洋马 YANMAR    |                |
| 发动机额定功率<br>Engine power                           | 14.5/2400    | kW/rpm         |
| 爬坡能力<br>Max. Gradeability                         | 30           | °              |
| 斗杆最大挖掘力<br>Max. digging force of arm              | 14.4         | kN             |
| 铲斗最大挖掘力<br>Max. digging force of bucket           | 23.1         | kN             |
| 行驶速度<br>Traveling speed                           | 4.2/2.3      | km/h           |
| 平台回转速度<br>Slewing speed of platform               | 10~12        | rpm            |
| <b>作业参数</b><br>Operating parameter                |              |                |
| 最大挖掘高度<br>Max. digging height                     | 4170         | mm             |
| 最大挖掘深度<br>Max. digging depth                      | 2540         | mm             |
| 最大挖掘半径<br>Max. digging radius                     | 4520         | mm             |
| 最大地面挖掘半径<br>Max. digging radius on ground level   | 4400         | mm             |
| 最大卸载高度<br>Max. dumping height                     | 2780         | mm             |
| 最小回转半径<br>Min. slewing radius                     | 1950         | mm             |
| 最大垂直挖深<br>Max. vertical digging depth             | 2240         | mm             |
| <b>运输尺寸</b><br>Transportation dimension           |              |                |
| 总长 (运输状态)<br>Overall length                       | 4110         | mm             |
| 总宽 (运输状态)<br>Overall width                        | 1500         | mm             |
| 总高 (运输状态)<br>Overall height                       | 2490         | mm             |
| <b>其他参数</b><br>Other Parameter                    |              |                |
| 履带宽度<br>Width of undercarriage                    | 1500         | mm             |
| 履带长度<br>Length of track                           | 2040         | mm             |
| 最小离地间隙<br>Height between undercarriage and ground | 320          | mm             |
| 平衡重离地高度<br>Height between platform and ground     | 525          | mm             |
| 尾部回转半径<br>Platform tail turning radius            | 750          | mm             |
| 燃油箱容量<br>Fuel tank capacity                       | 30           | L              |
| 液压油箱容量<br>Hydraulic oil tank capacity             | 25           | L              |