

Product Data Sheet

Product Datasheet

MND1 Nitrogen Dioxide Sensor

Document Purpose

The purpose of this document is to present the performance specification of the MND1 Nitrogen Dioxide gas sensor.

This document should be used in conjunction with Operating instructions mttoxops.pdf and the Product Safety Datasheet (PSDS 5).

The data provided in this document are valid at 20°C, 50% RH and 1013 mBar for 3 months from the date of sensor manufacture.

Output signal can drift below the lower limit over time. For guidance on the safe use of the sensor, please refer to Operating instructions mttoxops.pdf.

Product Data Sheet

Key Features & Benefits:

- Capable of continuous measurement
- 4th electrode for additional temperature stability

Technical Specifications

MEASUREMENT

Operating Principle	4-electrode electrochemical
Measurement Range	0-50 ppm NO ₂
Maximum Overload	200 ppm
Output Signal*	0.5 ± 0.1 µA/ppm
Response Time (T₉₀)*	< 40 seconds
Typical Baseline Offset * (clean air)	-0.75 to +0.75 ppm equivalent
Maximum Zero Shift (+20°C to +40°C)	0.5 ppm equivalent
Repeatability	2% of signal
Linearity	Linear

ELECTRICAL

Recommended Load Resistor	10 Ω
Bias Voltage	Not Required
Recommended Gain	0.8

MECHANICAL

Weight	21 g (nominal)
Housing Material	20% glass-filled polypropylene
Colour Coded Ring	Black
Orientation	Any

ENVIRONMENTAL

Typical Applications	Inhaled Nitric Oxide Therapy
Operating Temperature Range	-20°C to +50°C
Recommended Storage Temp	0°C to +20°C
Operating Pressure Range	800 - 1200 mBar
Differential Pressure Range	±100 mBar
Operating Humidity Range	15% to 90% RH non-condensing

LIFETIME

Typical Long Term Output Drift	2% signal loss/month
Expected Operating Life	1 year
Standard Warranty	12 months from date of despatch

Product Dimensions

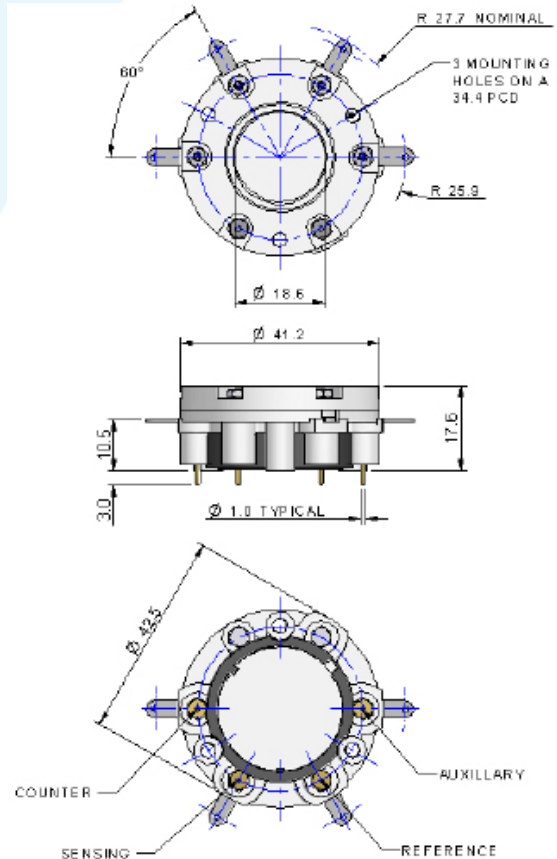

All dimensions in mm

All tolerances ±0.15 mm unless otherwise stated

IMPORTANT NOTE:

Connection should be made via recommended mating parts only. Soldering to the sensor will damage it and invalidate the warranty.

All performance data is based on measurements made with cylinder gases using a flow rate of 100 mls/min. Conditions at 20°C, 50% RH and 1013 mBar, using City Technology recommended circuitry. For sensor performance data under other conditions, contact City Technology.

* Specifications are valid at 20°C, 50% RH and 1013 mBar, using City Technology recommended circuitry. Performance characteristics outline the performance of sensors supplied within the first 3 months. Output signal can drift below the lower limit over time.

Product Data Sheet

Poisoning

MediceLs are designed for operation in a wide range of environments and harsh conditions, however it is important that exposure to high concentrations of solvent vapours is avoided, both during storage, fitting into instruments and operation.

When using sensors with printed circuit boards (PCBs), degreasing agents should be used before the sensor is fitted. Do not glue directly on or near the CiTiceL as the solvent may cause crazing of the plastic.

Cross Sensitivity Table

Whilst MediceLs are designed to be highly specific to the gas they are intended to measure, they will still respond to some degree to various other gases. The table below is not exclusive and other gases not included in the table may still cause a sensor to react.

IMPORTANT NOTE : The cross sensitivity data shown below does not form part of the product specification and is supplied for guidance only. Values quoted are based on tests conducted on a small number of sensors and any batch may show significant variation. For the most accurate measurements, an instrument should be calibrated using the gas under investigation.

<u>Gas</u>	<u>Response</u>
Carbon Monoxide (CO)	None
Nitrous Oxide (N ₂ O)	None
Nitric Oxide (NO)	None
Desflurane	None
Isoflurane	None
Halothane	None

N.B. Unaffected by operation in 100% oxygen

SAFETY NOTE

This sensor is designed to be used in safety critical applications. To ensure that the sensor and/or instrument in which it is used, are operating properly, it is a requirement that the function of the device is confirmed by exposure to target gas (bump check) before each use of the sensor and/or instrument. Failure to carry out such tests may jeopardize the safety of people and property.

Every effort has been made to ensure the accuracy of this document at the time of printing. In accordance with the company's policy of continued product improvement City Technology Limited reserves the right to make product changes without notice. The products are always subject to a programme of improvement and testing which may result in some changes in the characteristics quoted. As the products may be used by the client in circumstances beyond the knowledge and control of City Technology Limited, we cannot give any warranty as to the relevance of these particulars to an application. It is the clients' responsibility to carry out the necessary tests to determine the usefulness of the products and to ensure their safety of operation in a particular application.